

### Description

The HTM7G06S035P is an unmatched discrete LDMOS Power Amplifier with 35W saturated output power covering frequency range for VHF/UHF applications.

### Features

- Operating Frequency Range: VHF/UHF
- Operating Drain Voltage: +12.5V
- Saturation Output Power: 35W
- Excellent thermal stability due to low thermal resistance package
- Enhanced robustness design without device degradation
- Internally integrated enhanced ESD design

Freq (MHz)	Vdd (V)	Pin (W)	Pout (W)	Eff (%)
136-174 <sup>[1]</sup>	12.5	2.0	44.9	61.2
400-470 <sup>[2]</sup>	12.5	2.5	38.9	61.4
400-470 <sup>[3]</sup>	12.5	2.5	75.5	62.1

Test conditions unless otherwise noted: 25 °C,

VDD = +12.5Vdc, IDQ= 500mA, CW Signal

[1] Based on 12.5V, VHF band,

[2] Based on 12.5V, UHF frequency band,

[3] Based on 12.5V, UHF frequency band, Push-Pull

### Applications

- VHF Band handheld Walkie-talkie
- UHF Band handheld Walkie-talkie
- Industrial Scientific Medical (ISM)
- Driver or Final stage Power Amplifier

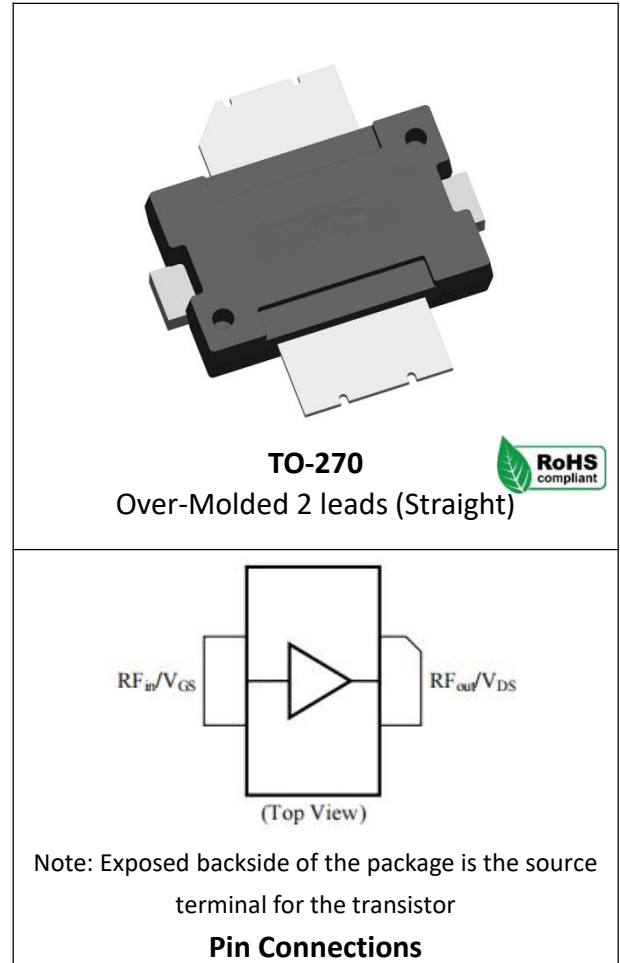

### Ordering Information

Part Number	Description
HTM7G06S035P	Reel Package
HTM7G06S035P EVB	470 - 700 MHz EVB
HTM7G06S035P EVB1	136 - 174 MHz EVB

### Absolute Maximum Ratings

Parameter	Range/Value	Unit
Drain voltage ( $V_{DSS}$ )	-0.5, +48	V
Gate voltage ( $V_{GS}$ )	-5 to +10	V
Operation voltage ( $V_{DD}$ )	+0 to +24	V
Storage Temperature ( $T_{STG}$ )	-55 to +150	°C
Junction Temperature ( $T_J$ )	-40 to +225	°C
Thermal Resistance Junction to Case ( $R_{TH}$ )	0.81	°C/W

### Electrical Specification

#### DC Characteristics

Parameter	Conditions	Min	Typ	Max	Unit
Breakdown Voltage $V_{(BR)DSS}$	$V_{GS}=0V, I_{DS}=100\mu A$	48	-	-	V
Gate-Source Threshold Voltage $V_{GS(th)}$	$V_{DS}=V_{GS}, I_{DS}=100\mu A$	0.8	1.3	1.8	V
Drain Leakage Current $I_{DSS}$	$V_{GS}=0V, V_{DS}=17V$	-	-	10	$\mu A$
Gate Leakage Current $I_{GSS}$	$V_{GS}=5V, V_{DS}=0V$	-	-	1	$\mu A$

#### Load Mismatch Test

Condition	Test Result
VSWR=20:1, at all Phase Angles, $V_{DD} = +17V_{dc}$ , $I_{DQ} = 500mA$ , CW signal 48dBm @156 MHz test on HOTLO Application Board	No Device Degradation
VSWR=20:1, at all Phase Angles, $V_{DD} = +17V_{dc}$ , $I_{DQ} = 500mA$ , CW signal 47.8dBm @435 MHz test on HOTLO Application Board	No Device Degradation

#### RF Characteristics (CW)

Freq (MHz)	Vdd (V)@Idq (mA)	Pin (W)	Pout (W)	Eff (%)
166 <sup>[1]</sup>	12.5@500	2.0	48	73
435 <sup>[2]</sup>	12.5@500	2.0	46	70
435 <sup>[3]</sup>	12.5@600	2.5	78	66

Test conditions unless otherwise noted: 25 °C, CW Signal

[1]Based on 12.5V, VHF band, reference design performance test

[2]Based on 12.5V, UHF frequency band, reference design performance test

[3]Based on 12.5V, UHF frequency band, Push-Pull reference design performance test

**CHANNEL DISSIPATION VS.  
AMBIENT TEMPERATURE**

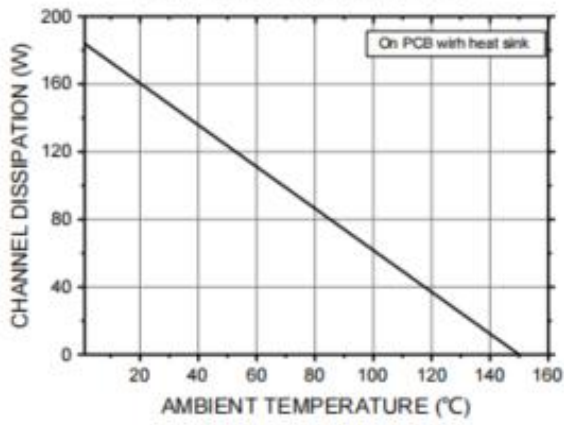

**IDS VS. VGS**

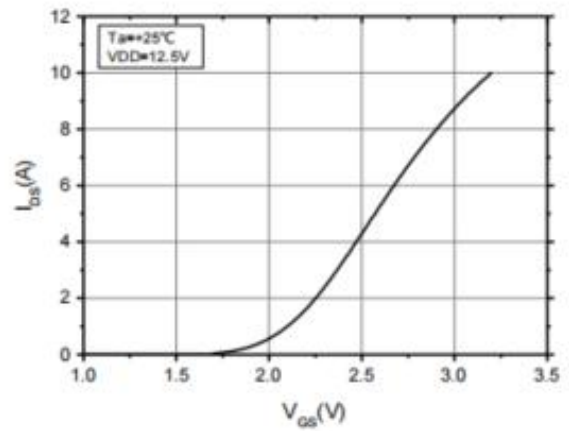

**Ciss VS. VGS**

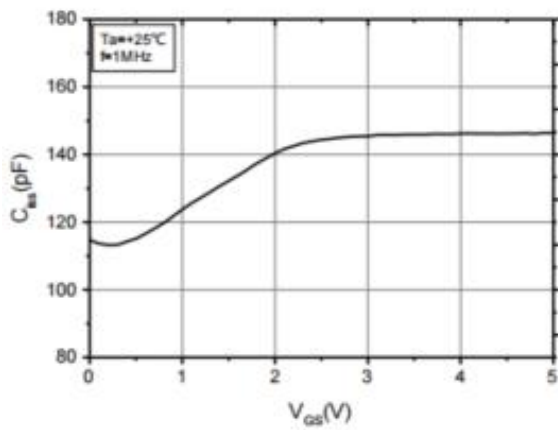

**Crss VS. VDS**

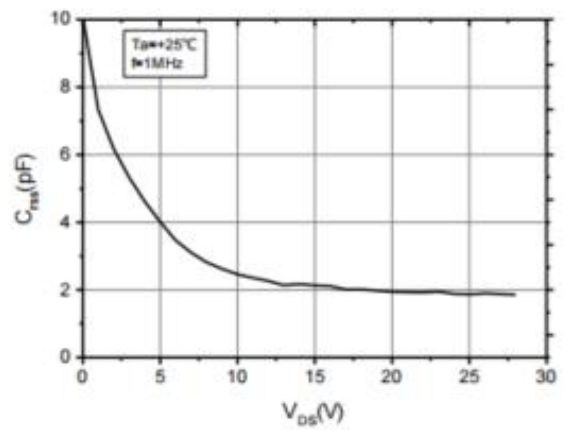

**Coss VS. VDS**

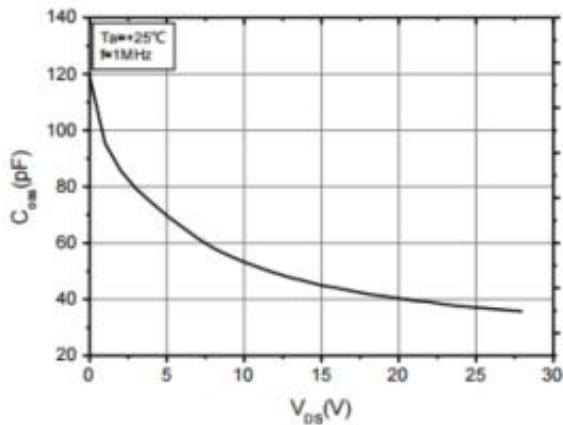

Test conditions unless otherwise noted: 25 °C, DC Characteristics

### HTM7G06S035P 136- 174 MHz Reference Design (VHF)

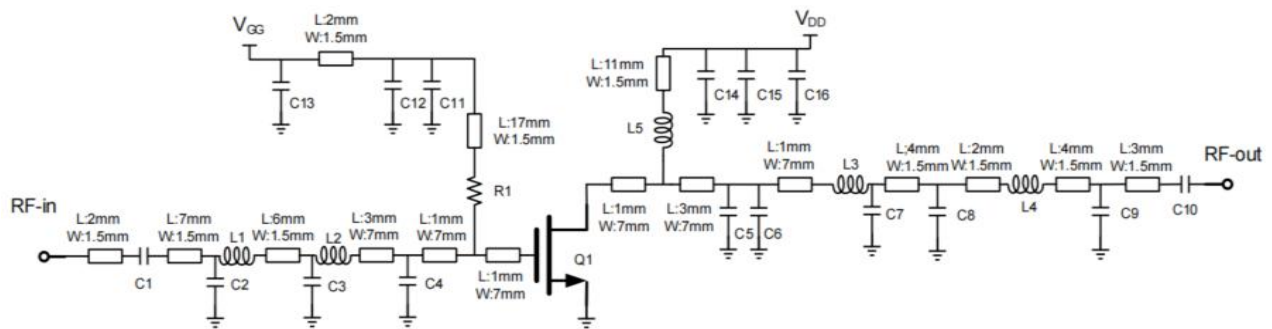

EVN Layout

### Bill of Materials (BoM) - HTM7G06S035P 136- 174 MHz Reference Design (VHF)

Reference	Value	Description	Manufacturer	P/N
Q1	-	35W, 1.8 - 600 MHz LDMOS PA	Holto	HTM7G06S035P
C1, C3	47pF	MLCC	Murata	GRM1885C1H470JA01
C2, C6	27pF	MLCC	Murata	GRM1885C1H270JA01
C4, C9	33pF	MLCC	Murata	GRM1885C1H330JA01
C5	180pF	MLCC	Murata	GRM1885C1H181JA01
C7, C8	39pF	MLCC	Murata	GRM1885C1H390JA01
C10	1nF	MLCC	Murata	GRM1885C1H102JA01
C11, C14	470pF	MLCC	Murata	GRM1885C1H471JA01
C12, C15	1nF	MLCC	Murata	GRM32ER61H102JA01
C13, C16	10uF	MLCC	Murata	GRM32ER61H105KA12L
L1	D: 0.31mm, Inside: 1.2mm, 4 Turns		-	Enameled wire
L2, L4	D: 0.35mm, Inside: 1.5mm, 3 Turns		-	Enameled wire
L3	D: 0.45mm, Inside: 1.2mm, 2 Turns		-	Enameled wire
L5	D: 1mm, Inside: 3mm, 4 Turns		-	Enameled wire
R1	51Ω	Thick Film Resistor	YAGEO	RC0603FR-0751RL
PCB	FR-4 (er = 4.3), 30 mil (0.762 mm), 35 μm (1oz)			

### Performance Plots 136- 174 MHz Reference Design (VHF)

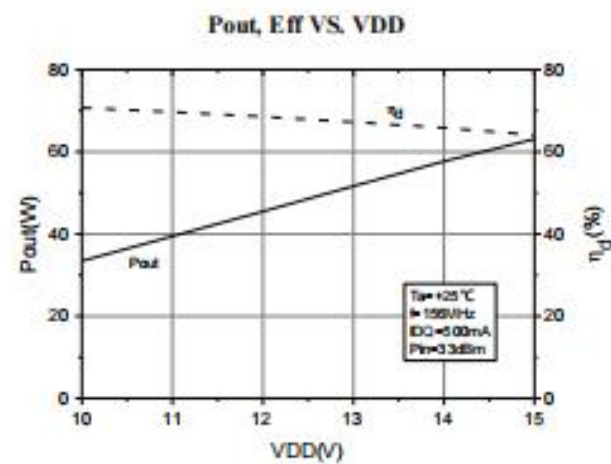
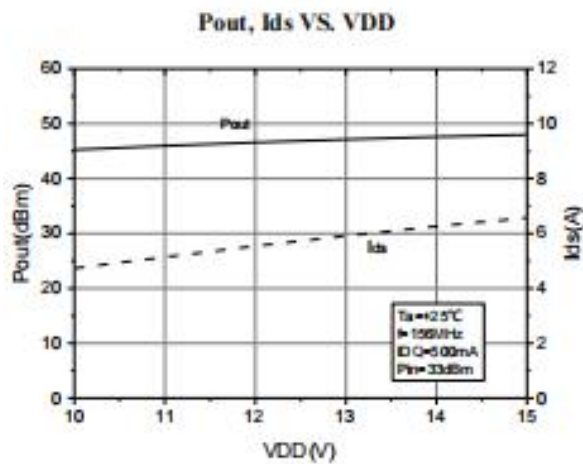
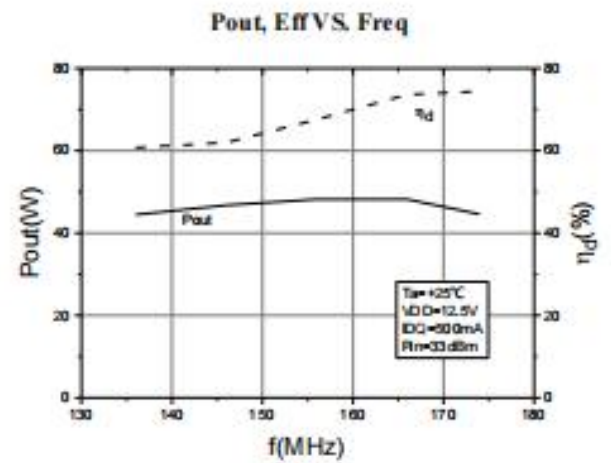
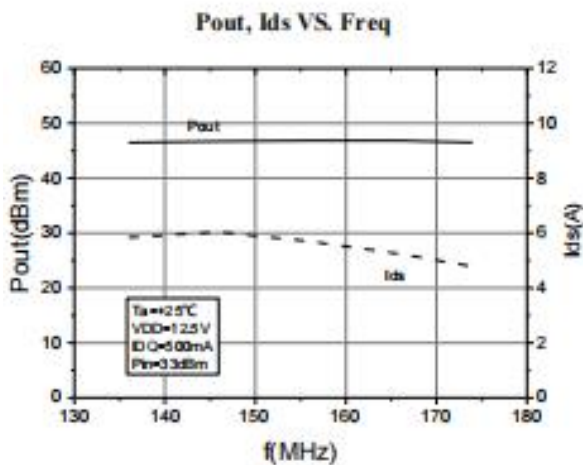
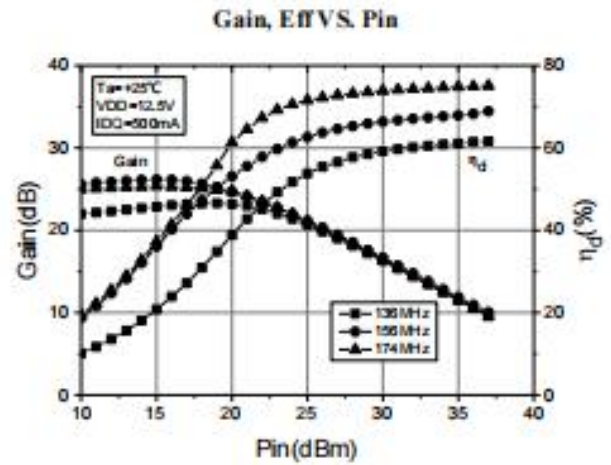
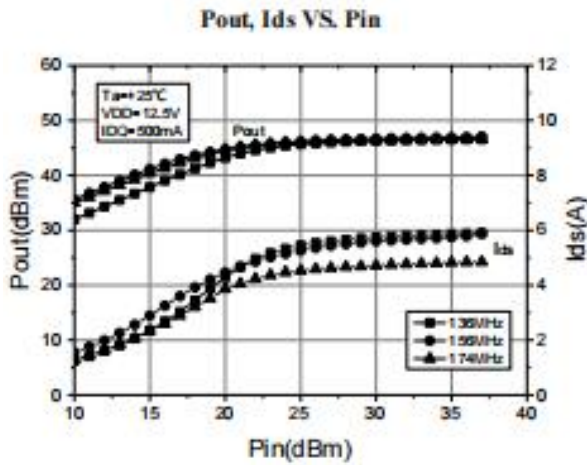

Test conditions unless otherwise noted:  $25^\circ\text{C}$ ,  $V_{DD} = +12.5\text{Vdc}$ ,  $IDQ = 500\text{mA}$ , CW test on HOTLO Application Board

### HTM7G06S035P 400 - 470 MHz Reference Design (UHF)

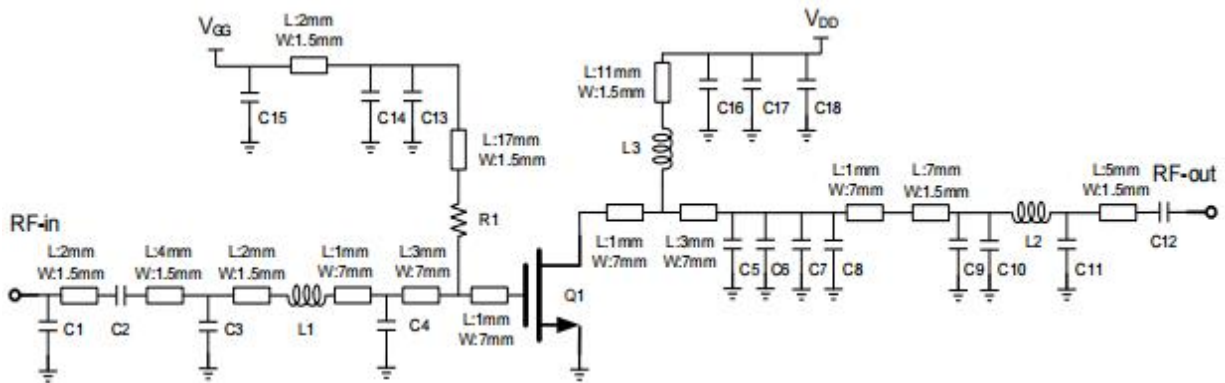

EVB Layout

### Bill of Materials (BoM) - HTM7G06S035P 400 - 470 MHz Reference Design (UHF)

Reference	Value	Description	Manufacturer	P/N
Q1	-	35W, 1.8 - 600 MHz LDMOS PA	Holto	HTM7G06S035P
C1	3pF	MLCC	Murata	GRM1885C1H3R0JA01
C2	30pF	MLCC	Murata	GRM1885C1H300JA01
C3, C7	22pF	MLCC	Murata	GRM1885C1H220JA01
C4, C5	18pF	MLCC	Murata	GRM1885C1H180JA01
C6	2pF	MLCC	Murata	GRM1885C1H2R0JA01
C8	27pF	MLCC	Murata	GRM1885C1H270JA01
C9, C10	20pF	MLCC	Murata	GRM1885C1H200JA01
C11	9pF	MLCC	Murata	GRM1885C1H9R0JA01
C12, C13, C16	100pF	MLCC	Murata	GRM1885C1H101JA01
C14, C17	1nF	MLCC	Murata	GRM32ER61H102JA01
C15, C18	10uF	MLCC	Murata	GRM32ER61H105KA12L
L1	D: 0.51mm, Inside: 1.2mm, 1 Turns		-	Enameled wire
L2	D: 0.51mm, Inside: 1.8mm, 2 Turns		-	Enameled wire
L3	D: 1mm, Inside: 3mm, 4 Turns		-	Enameled wire



# HTM7G06S035P

## 35W, 1.8 - 600 MHz LDMOS Amplifier

Product datasheet

Reference	Value	Description	Manufacturer	P/N
R1	51Ω	Thick Film Resistor	YAGEO	RC0603FR-0751RL
PCB	FR-4 (er = 4.3), 30 mil (0.762 mm), 35 μm (1oz)			

### Performance Plots 400 - 470 MHz Reference Design (UHF)

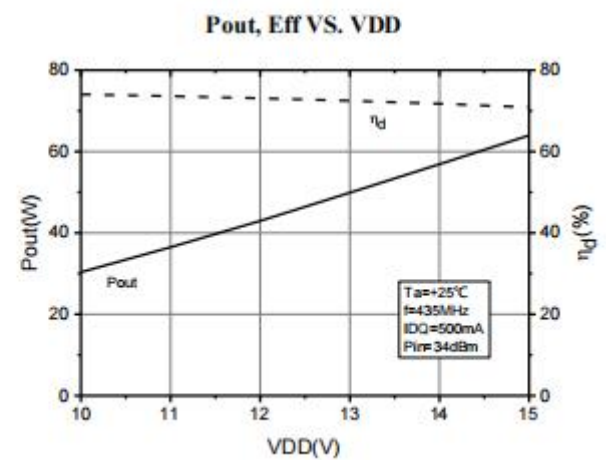
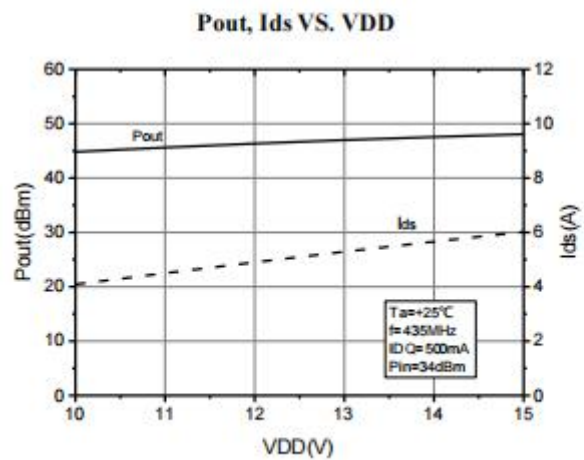
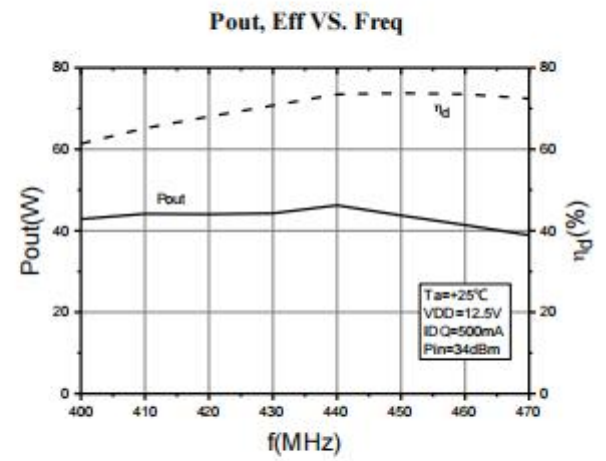
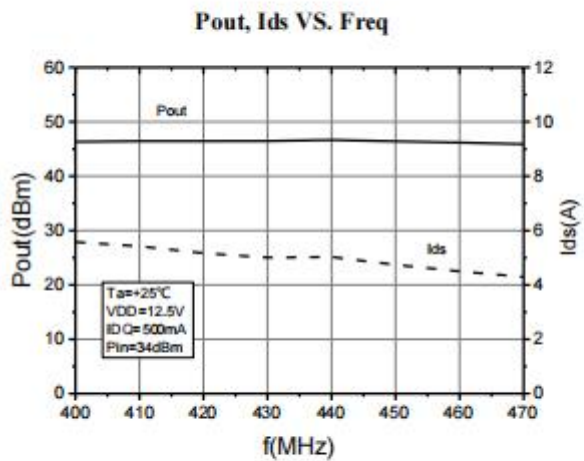
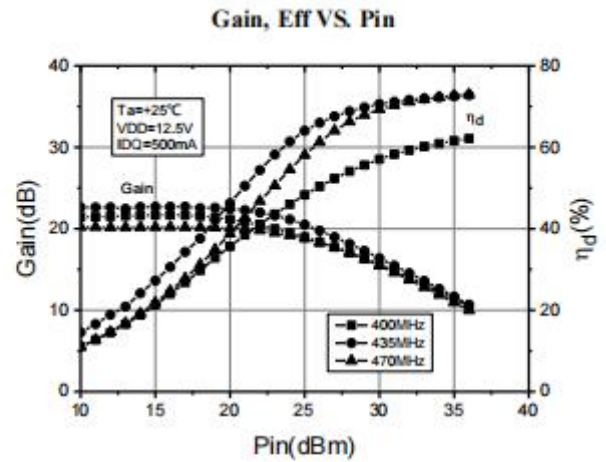
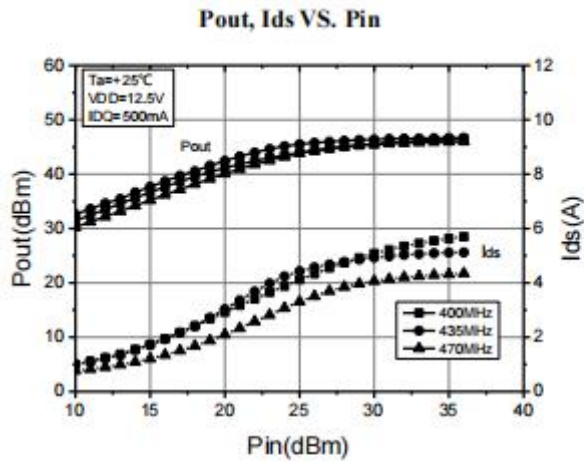

Test conditions unless otherwise noted:  $25^\circ\text{C}$ ,  $V_{DD} = +12.5\text{Vdc}$ ,  $I_{DQ} = 500\text{mA}$ , CW test on HOTLO Application Board

### HTM7G06S035P Push-Pull 400 - 470 MHz Reference Design (UHF)

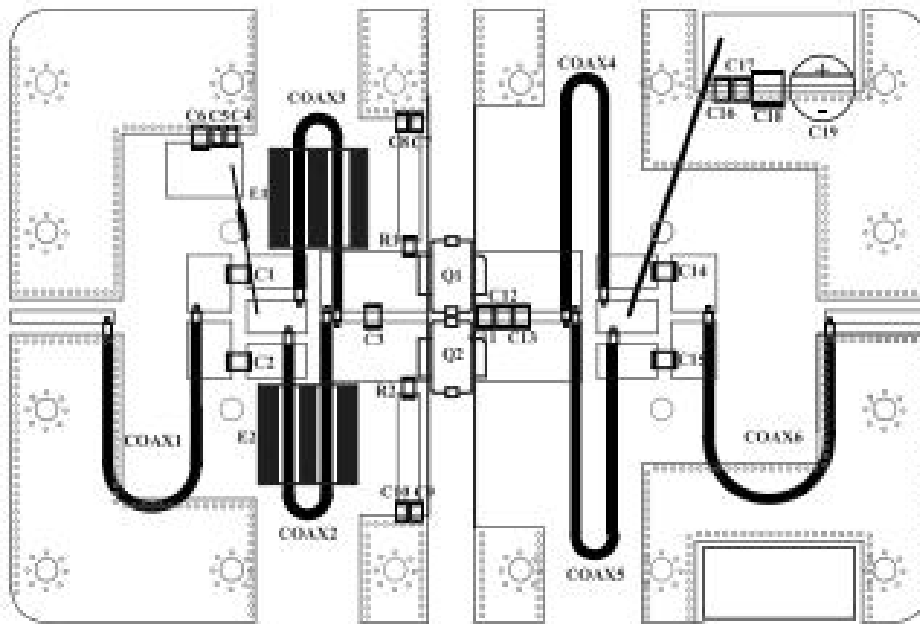

EVB Layout

### Bill of Materials (BoM) - HTM7G06S035P Push-Pull 400 - 470 MHz Reference Design

Reference	Value	Description	Manufacturer	P/N
Q1	-	35W, 1.8 - 600 MHz LDMOS PA	Holto	HTM7G06S035P
C1, C2, C14, C15, C16	100pF	MLCC	ATC	ATC100B101JT500XT
C4, C7, C9	100pF	MLCC	TDK	GRM1885C1H101JA01D
C5, C8, C10	10nF	MLCC	Murata	GR321AD72E103KW01D
C6	10uF	MLCC	-	-
C11, C12	20pF	MLCC	ATC	ATC100B200JT500XT
C16	15pF	MLCC	ATC	ATC100B150JT500XT
C17	1000pF	MLCC	ATC	ATC100B102JT500XT
C18	10uF	MLCC	AVX	22201C106MAT2A
C19	470uF	Electrolytic Capacitors	-	-
E1, E2	#61 Multi-Aperture Core		Fair-Rite	2861000302

Reference	Value	Description	Manufacturer	P/N
Coax1,6	50 $\Omega$ SR Coax, 166 mm			
Coax2,3	25 $\Omega$ SR Coax, 60 mm			
Coax4,5	16 $\Omega$ SR Coax, 80 mm			
R1, R2	51 $\Omega$	Thick Film Resistor	-	-
R3	1K $\Omega$	Wire Resistors	-	-
PCB	FR-4 (er = 4.3), 30 mil (0.762 mm), 35 $\mu$ m (1oz)			

### Performance Plots Push-Pull 400 - 470 MHz Reference Design (UHF)

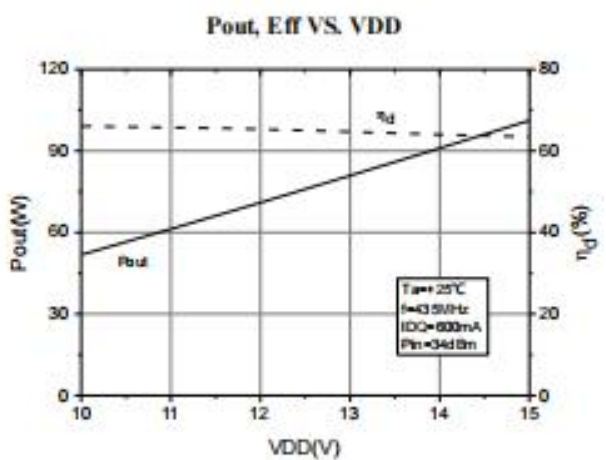
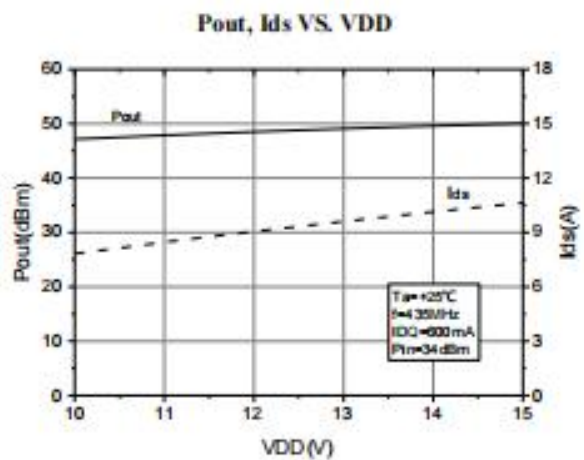
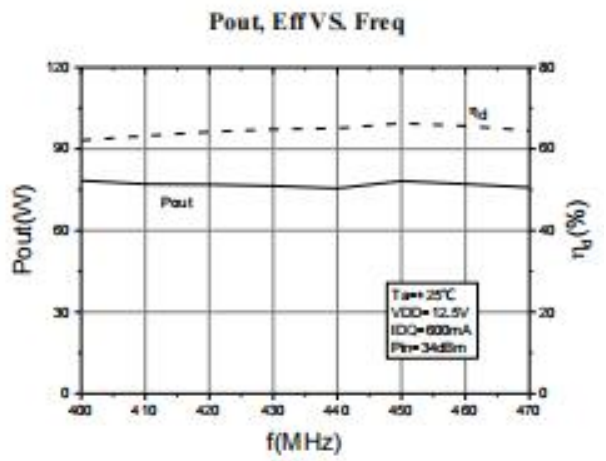
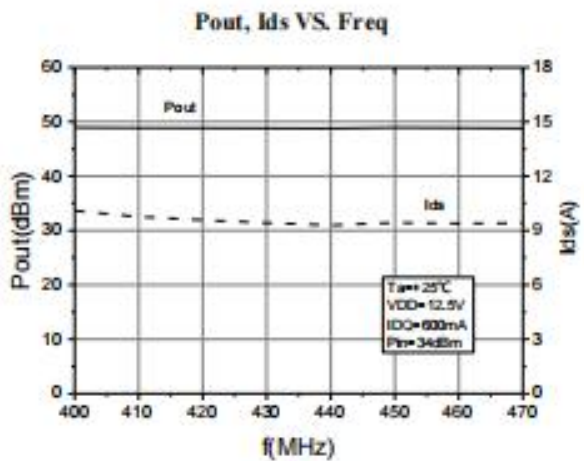
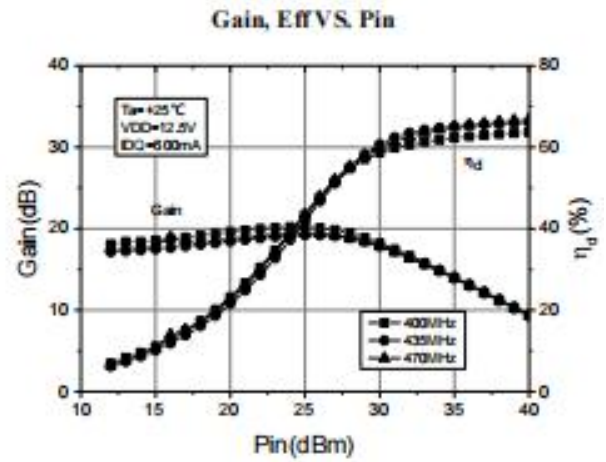
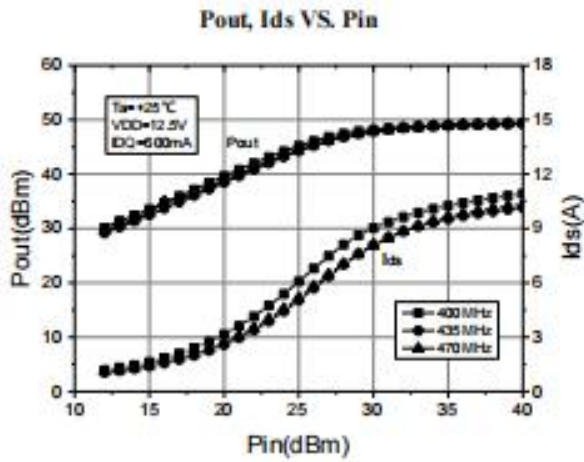

Test conditions unless otherwise noted:  $25^\circ\text{C}$ ,  $V_{DD} = +12.5\text{Vdc}$ ,  $I_{DQ} = 500\text{mA}$ , CW test on HOTLO Application Board

### Package Marking and Dimensions

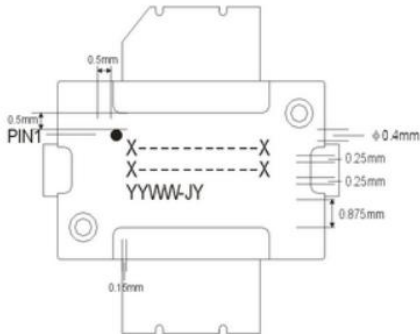

- Line1 (fixed): Device name in W/O
- Line2 (unfixed): Marking Lot No in W/O (Sample: E596-20140001)
- Line3 (unfixed): Date Code + JY

This Marking SPEC only stipulates the content of Marking. For marking requirements such as font and size, please refer to the latest version of “Holto Product Printing Specification”

### Marking

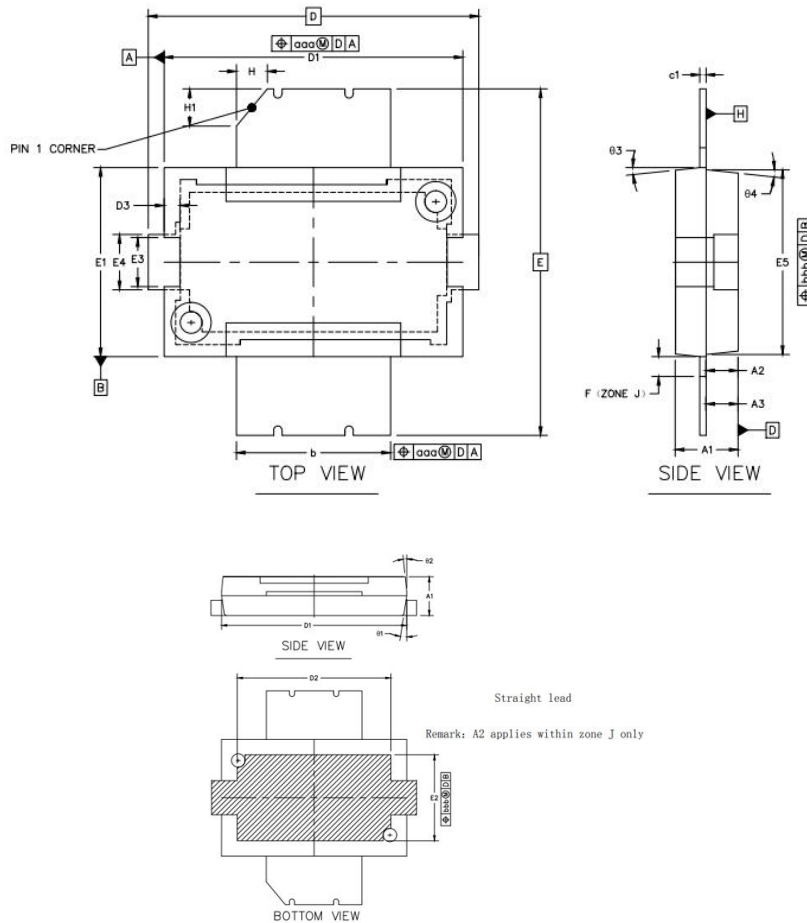



# HTM7G06S035P

## 35W, 1.8 - 600 MHz LDMOS Amplifier

Product datasheet

		SYMBOL	MIN	NOM	MAX
TOTAL THICKNESS		A1	1.98	2.03	2.08
MOLD THICKNESS		A2	1.02	1.045	1.07
		A3	0.99	1.04	1.09
L/F THICKNESS		C1	0.203 REF		
BODY SIZE	X	D	10.57	10.67	10.77
	Y	E	11.08	11.18	11.28
GROOVE SIZE	X	D2	7.37 MIN		
	Y	E2	3.81 MIN		
MOLD LENGTH		D1	9.6	9.65	9.7
LENGTH		D3	0.41	0.51	0.61
MOLD WIDTH		E1	6.05	6.1	6.15
WIDTH		E3	1.48	1.58	1.68
		E4	1.68	1.78	1.88
		E5	5.91	5.96	6.01
ZONE WIDTH		F	0.64 BSC		
LEAD WIDTH		b	4.9	4.98	5.06
PACKAGE EDGE TOLERANCE		aaa	0.1		
LEAD OFFSET		bbb	0.2		
TAPER ANGLE		θ1	7°	9°	11°
		θ2	4°	6°	8°
		θ3	4°	6°	8°
		θ4	4°	6°	8°
PIN1 SIZE		H	1 REF		
		H1	1.2 REF		

Package Dimensions

### Tape and Reel Information

Package Type	Reel Size(inch)	Qty/Reel(pcs)	Qty/Box(pcs)	Qty/Carton(pcs)
TO270	13inch	1500	1500	7500

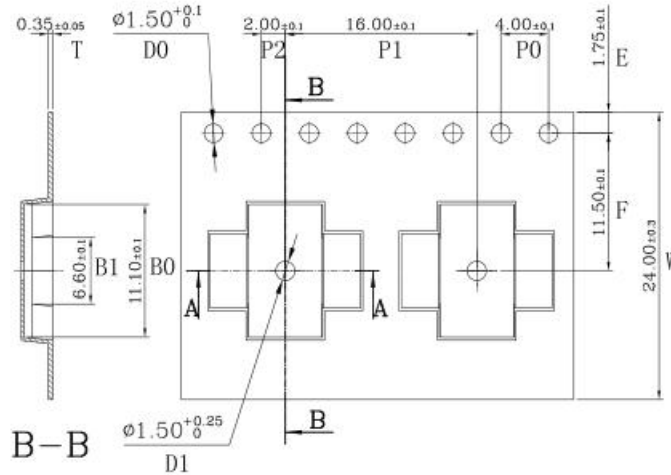

Tape & Reel Packaging Descriptions

### Handling Precautions

Parameter	Rating	Standard	
ESD – Human Body Model (HBM)	Class 1B	JESD22-A114	
ESD – Human Body Model (MM)	Class A	EIA/JESD22-A115	
ESD – Charged Device Model (CDM)	Class III	JESD22-C101	

### RoHS Compliance

This product is compliant with the 2011/65/EU RoHS directive (Restrictions on the Use of Certain Hazardous Substances in Electrical and Electronic Equipment), as amended by Directive 2015/863/EU.

### Datasheet Status

Document status	Product status	Definition
Objective Datasheet	Design simulation	Product objective specification
Preliminary Datasheet	Customer sample	Engineering samples and first test results
Product Datasheet	Mass production	Final product specification

## Abbreviations

---

Acronym	Definition
LDMOS	Laterally-Diffused Metal-Oxide Semiconductor
CW	Continuous Waveform

## Revision history

---

Document ID	Datasheet Status	Release Date	Revision Version
Rev 2.2	Product	March 2023	New format based on English version datasheet
Rev 2.3	Product	March 2024	Version released after re review
Rev 2.4	Product	May 2024	Update package 3D picture

## Contact Information

---

For the latest specifications, additional product information, worldwide sales and distribution locations and information about HOLTLO:

- Web: [www.andesource.com](http://www.andesource.com)
- Email: [andehk@andesource.com](mailto:andehk@andesource.com)

For technical questions and application information:

- Email: [andetech@andesource.com](mailto:andetech@andesource.com)

## Important Notice

---

Information in this document is believed to be accurate and reliable. However, HOLTLO does not give any representations or warranties, expressed or implied, as to the accuracy or completeness of such information and shall have no liability for the consequences of use of such information.

“Typical” parameters are the average values expected by HOLTLO in large quantities and are provided for information purposes only. All information and specifications contained herein are subject to change without notice and customers should obtain and verify the latest relevant information before placing orders for HOLTLO products.

The information contained herein or any use of such information does not grant, explicitly or implicitly, to any party any patent rights, licenses, or any other intellectual property rights, whether with regard to such information itself or anything described by such information.

Applications that are described herein for any of these products are for illustrative purposes only. HOLTLO makes no representation or warranty that such applications will be suitable for the specified use without further testing or modification. Customers are responsible for the design and operation of their applications and products using HOLTLO products, and HOLTLO accepts no liability for any assistance with applications or customer product design. It is customer's sole responsibility to determine whether the HOLTLO product is suitable and fit for the customer's applications and products planned, as well as for the planned application and use of customer's third-party customer(s). Customers should provide appropriate design and operating safeguards to minimize the risks associated with their applications and products.

HOLTLO products are not designed, authorized or warranted to be suitable for use in life support, life-critical or safety- critical systems or equipment, nor in applications where failure or malfunction of a HOLTLO product can reasonably be expected to result in personal injury, death or severe property or environmental damage. This document as well as the item(s) described herein may be subject to export control regulations. Export might require a prior authorization from competent authorities.