

(v) Preliminary Specifications

( ) Final Specifications

<b>Module</b>	<b>15 Inch Color TFT-LCD</b>
<b>Model Name</b>	<b>G150XAN02.2</b>

<i>Customer</i>	<i>Date</i>
_____	_____
<i>Checked &amp; Approved by</i>	<i>Date</i>
_____	_____
<i>Customer's sign back page</i>	

<i>Approved by</i>	<i>Date</i>
<i>Derek Hsu</i>	<i>2021.12.27</i>
<i>Prepared by</i>	<i>Date</i>
<i>Ginger Lin</i>	<i>2021.12.27</i>
<i>General Display Business Unit / AUO Display Plus corporation</i>	

## Contents

<b>1. Operating Precautions .....</b>	<b>4</b>
<b>2. General Description.....</b>	<b>5</b>
2.1 Display Characteristics .....	5
2.2 Optical Characteristics .....	6
<b>3. Functional Block Diagram.....</b>	<b>9</b>
<b>4. Absolute Maximum Ratings .....</b>	<b>10</b>
4.1 Absolute Ratings of TFT LCD Module .....	10
4.2 Absolute Ratings of Environment .....	10
<b>5. Electrical Characteristics .....</b>	<b>11</b>
5.1 TFT LCD Module .....	11
5.2 Backlight Unit .....	13
<b>6. Signal Characteristic .....</b>	<b>14</b>
6.1 Pixel Format Image .....	14
6.2 Scanning Direction.....	14
6.3 Signal Description .....	15
6.4 The Input Data Format.....	16
6.5 Interface Timing.....	17
6.6 Power ON/OFF Sequence.....	18
<b>7. Connector &amp; Pin Assignment.....</b>	<b>19</b>
7.1 TFT LCD Module: LVDS Connector.....	19
7.2 LED Backlight Unit: LED Driver Connector .....	20
7.3 LED Driver Connector Pin Assignment.....	20
<b>8. Reliability Test Criteria .....</b>	<b>21</b>
<b>9. Mechanical Characteristics.....</b>	<b>22</b>
9.1 LCM Outline Dimension (Front View) .....	22
9.2 LCM Outline Dimension (Rear View) .....	23
<b>10. Label and Packaging .....</b>	<b>24</b>
10.1 Shipping Label (on the rear side of TFT-LCD display).....	24
10.2 Carton Package .....	24
10.3 Palletizing .....	25
<b>11 Safety.....</b>	<b>26</b>
11.1 Sharp Edge Requirements .....	26
11.2 Materials .....	26
11.3 Capacitors.....	26
11.4 National Test Lab Requirement .....	26



## 1. Operating Precautions

- 1) Since front polarizer is easily damaged, please be cautious and not to scratch it.
- 2) Be sure to turn off power supply when inserting or disconnecting from input connector.
- 3) Wipe off water drop immediately. Long contact with water may cause discoloration or spots.
- 4) When the panel surface is soiled, wipe it with absorbent cotton or soft cloth.
- 5) Since the panel is made of glass, it may be broken or cracked if dropped or bumped on hard surface.
- 6) Since CMOS LSI is used in this module, take care of static electricity and insure human earth when handling.
- 7) Do not open nor modify the module assembly.
- 8) Do not press the reflector sheet at the back of the module to any direction.
- 9) In case if a module has to be put back into the packing container slot after it was taken out from the container, do not press the center of the LED Reflector edge. Instead, press at the far ends of the LED Reflector edge softly. Otherwise the TFT Module may be damaged.
- 10) At the insertion or removal of the Signal Interface Connector, be sure not to rotate nor tilt the Interface Connector of the TFT Module.
- 11) TFT-LCD Module is not allowed to be twisted & bent even force is added on module in a very short time. Please design your display product well to avoid external force applying to module by end-user directly.
- 12) Small amount of materials without flammability grade are used in the TFT-LCD module. The TFT-LCD module should be supplied by power complied with requirements of Limited Power Source (IEC60950-1 or UL60950-1), or be applied exemption.
- 13) Severe temperature condition may result in different luminance, response time.
- 14) Continuous operating TFT-LCD Module under high temperature environment may accelerate LED light bar exhaustion and reduce luminance dramatically.
- 15) The data on this specification sheet is applicable when TFT-LCD module is placed in landscape position.
- 16) Continuous displaying fixed pattern may induce image sticking. It's recommended to use screen saver or moving content periodically if fixed pattern is displayed on the screen.

## 2. General Description

G150XAN02.2 is a Color Active Matrix Liquid Crystal Display composed of a TFT-LCD display, a driver circuit, and a backlight system. The screen format is intended to support XGA (1024(H) x 768(V)) screen and 16.2M (RGB 6+2FRC) colors. All input signals are LVDS interface compatible.

G150XAN02.2 is designed for industrial display applications.

### 2.1 Display Characteristics

The following items are characteristics summary on the table under 25 °C condition:

Items	Unit	Specifications
Screen Diagonal	[inch]	15
Active Area	[mm]	304.128(H) x 228.096(V)
Pixels H x V		1024x3(RGB) x 768
Pixel Pitch	[mm]	0.297 x 0.297
Pixel Arrangement		R.G.B. Vertical Stripe
Display Mode		AHVA
Nominal Input Voltage VDD	[Volt]	3.3 typ.
Typical Power Consumption	[Watt]	25.32 (max.)
Weight	[Grams]	950g (max.)
Physical Size	[mm]	326.5(H) x 253.5(V) x 9.3 (D) typ.
Electrical Interface		LVDS
Surface Treatment		Anti-Reflection, 3H
Support Color		16.2M colors
Temperature Range (Panel Surface Temperature)		
Operating	[°C]	-30 to +70°C
Storage (Non-Operating)	[°C]	-30 to +70°C
RoHS Compliance		RoHS Compliance
Light Bar Unit		LED, Non-Replaceable

## 2.2 Optical Characteristics

The optical characteristics are measured under stable conditions at 25 °C (Room Temperature) under 60Hz:

Item	Unit	Conditions	Min.	Typ.	Max.	Note
White Luminance	[cd/m <sup>2</sup> ]		1600	(1800)	-	1
Uniformity	%	9 Points	75	80	-	1, 2, 3
Contrast Ratio			800	1000	-	4
Cross talk	%		-	-	1.5	5
Response Time	[msec]	Rising	-	-	-	6
	[msec]	Falling	-	-	-	
	[msec]	Raising + Falling	-	25	30	
Viewing Angle	[degree]	Horizontal (Right) CR = 10 (Left)	80	89	-	7
	[degree]		80	89	-	
	[degree]	Vertical (Upper) CR = 10 (Lower)	80	89	-	
	[degree]		80	89	-	
Color / Chromaticity Coordinates (CIE 1931)		Red x	-0.050	0.619	+0.050	
		Red y		0.352		
		Green x		0.329		
		Green y		0.609		
		Blue x		0.150		
		Blue y		0.118		
		White x		0.313		
		White y		0.329		
Color Gamut	%		-	60	-	

Note 1: Measurement method

Equipment Pattern Generator, Power Supply, Digital Voltmeter, Luminance meter (SR\_3 or equivalent)

Aperture 1φ with 50cm viewing distance

Test Point Center

Environment < 1 lux

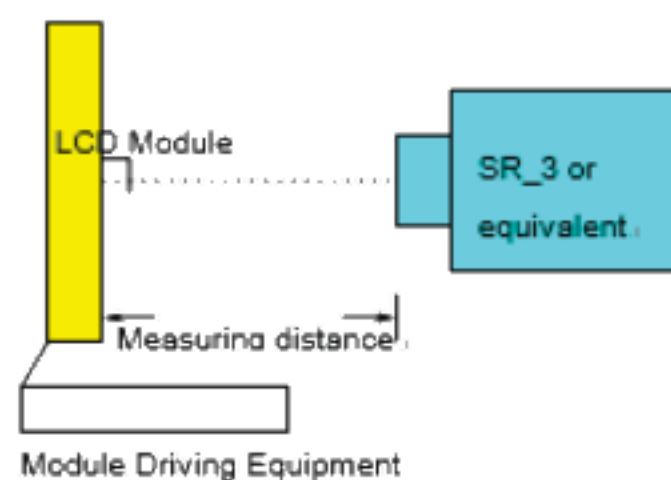

Note 2: Definition of 9 points position (Display active area: 304.128(H) x 228.096(V))

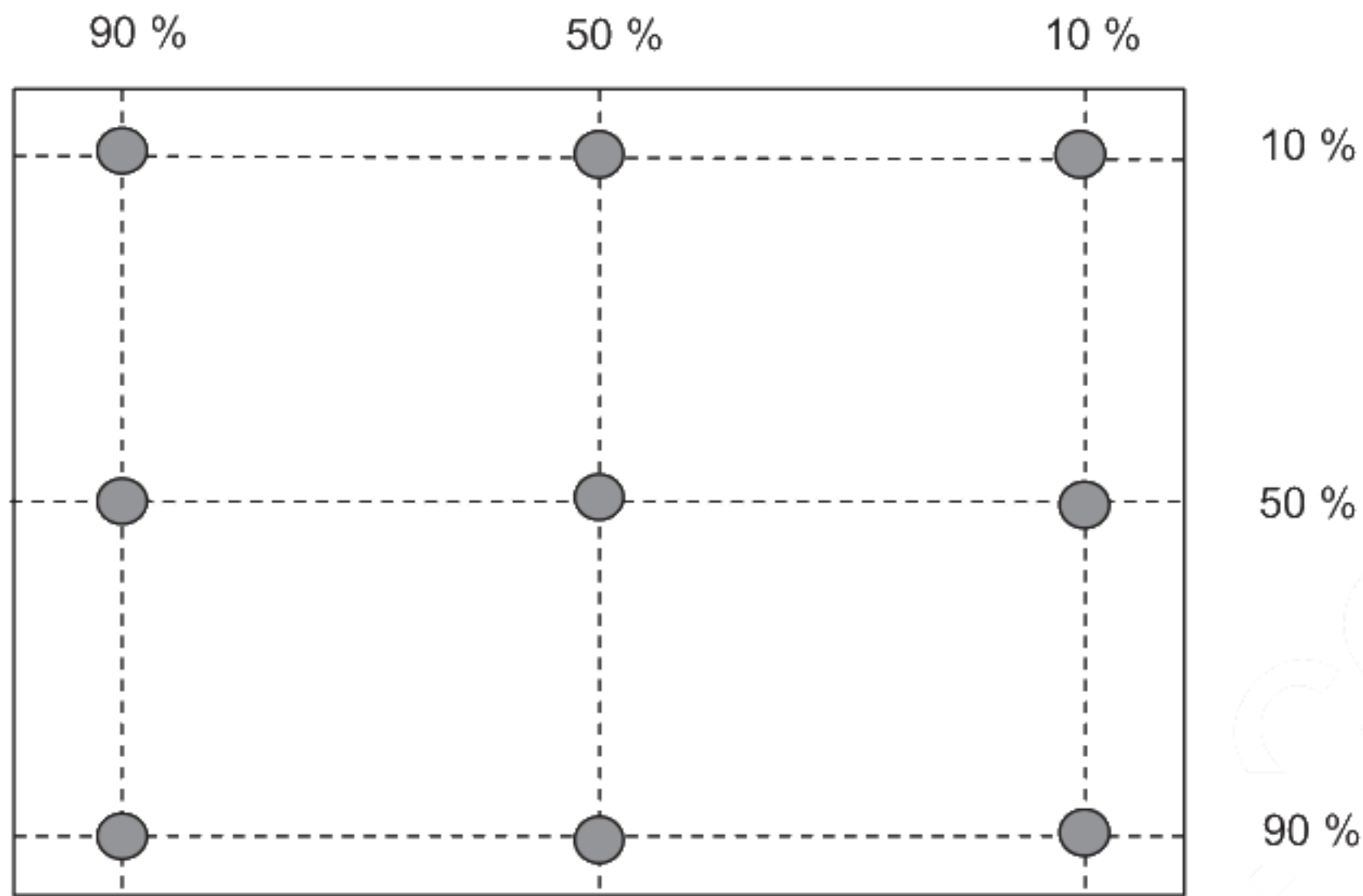

Note 3: The luminance uniformity of 9 points is defined by dividing the minimum luminance values by the maximum test point luminance

$$\delta_{w9} = \frac{\text{Minimum Brightness of nine points}}{\text{Maximum Brightness of nine points}}$$

Note 4 : Definition of contrast ratio (CR):

$$\text{Contrast ratio (CR)} = \frac{\text{Brightness on the "White" state}}{\text{Brightness on the "Black" state}}$$

Note 5 : Definition of cross talk (CT)

$$CT = | YB - YA | / YA \times 100 (\%)$$

Where

YA = Luminance of measured location without gray level 0 pattern (cd/m2)

YB = Luminance of measured location with gray level 0 pattern (cd/m2)

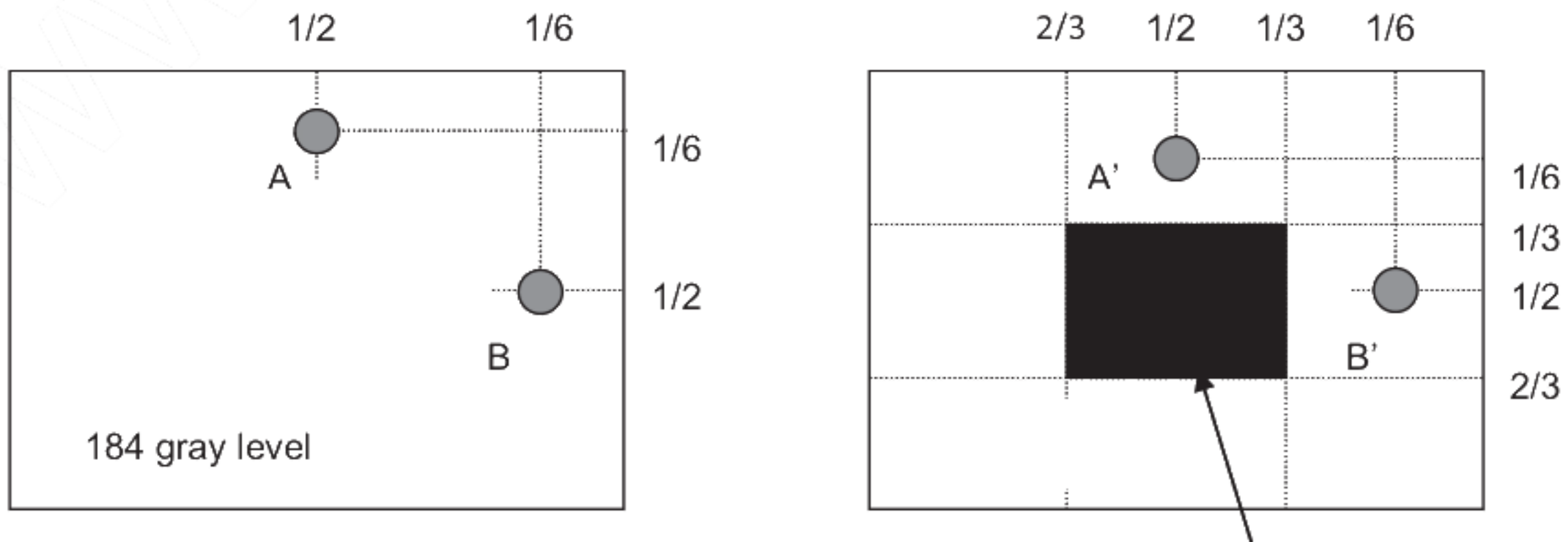

Note 6: Definition of response time:

The output signals of photo detector are measured when the input signals are changed from "White" to "Black" (falling time) and from "Black" to "White" (rising time), respectively. The response time interval is between 10% and 90% of amplitudes. Please refer to the figure as below.

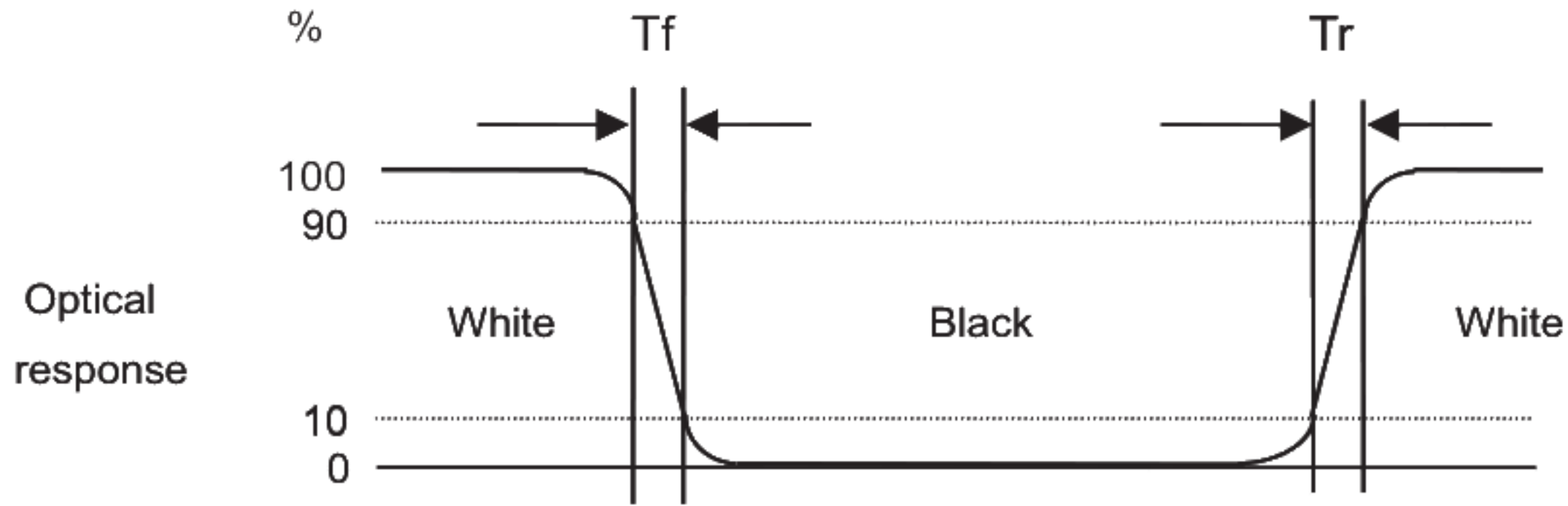

Note 7: Definition of viewing angle

Viewing angle is the measurement of contrast ratio  $\geq 10$ , at the screen center, over a  $180^\circ$  horizontal and  $180^\circ$  vertical range (off-normal viewing angles). The  $180^\circ$  viewing angle range is broken down as below:  $90^\circ$  ( $\theta$ ) horizontal left and right, and  $90^\circ$  ( $\phi$ ) vertical high (up) and low (down). The measurement direction is typically perpendicular to the display surface with the screen rotated to its center to develop the desired measurement viewing angle.

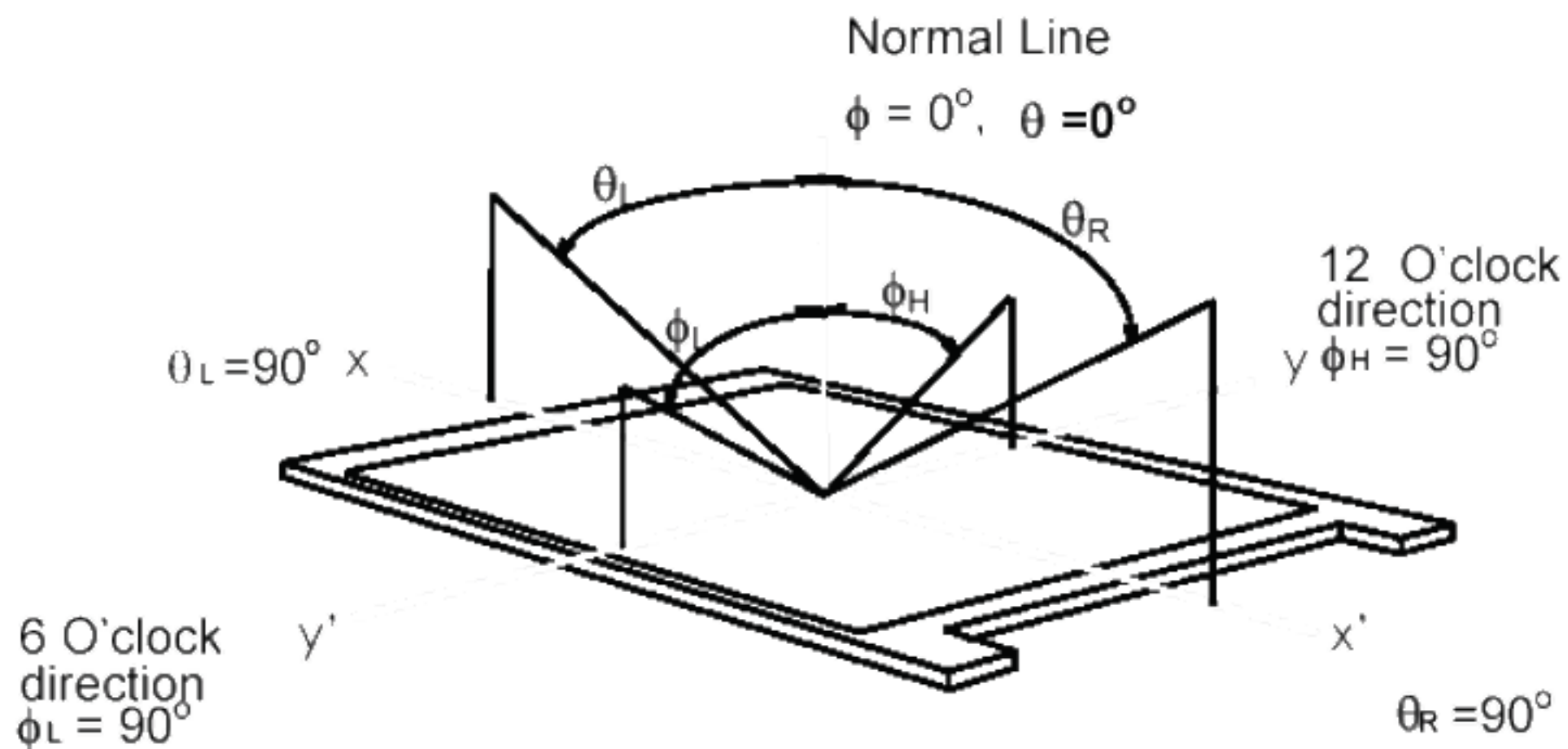



### 3. Functional Block Diagram

The following diagram shows the functional block of the 15inch color TFT/LCD module:

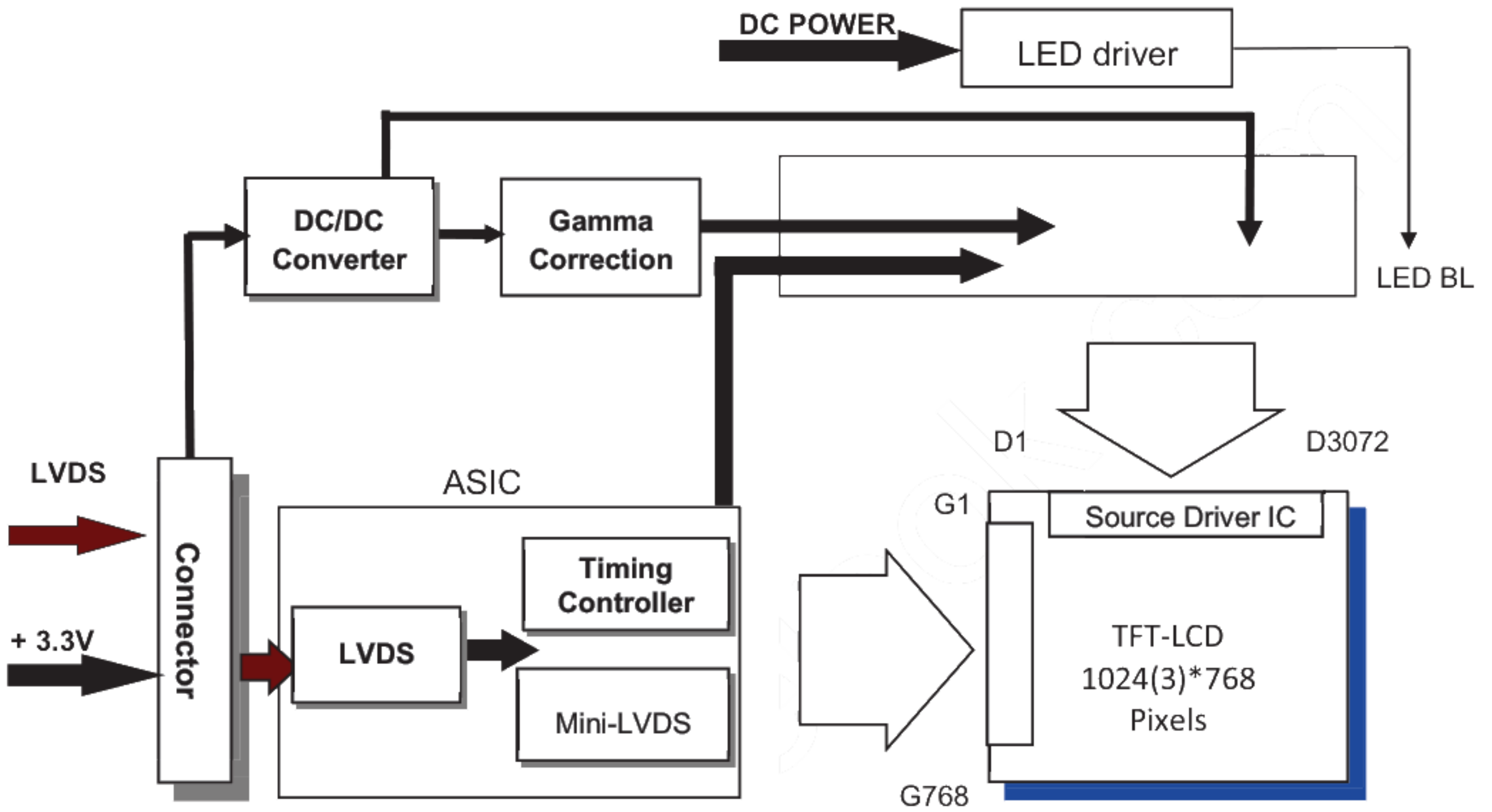

## 4. Absolute Maximum Ratings

### 4.1 Absolute Ratings of TFT LCD Module

Item	Symbol	Min	Max	Unit
Logic/LCD drive Voltage	Vin	-0.3	+3.6	[Volt]

### 4.2 Absolute Ratings of Environment

Item	Symbol	Min	Max	Unit
Operating Temperature	TOP	-30	+70*	[°C]
Operation Humidity	HOP	8	90	[%RH]
Storage Temperature	TST	-30	+70*	[°C]
Storage Humidity	HST	8	90	[%RH]

Note: Maximum Wet-Bulb should be 39°C and no condensation.

\* 70°C is panel surface temperature

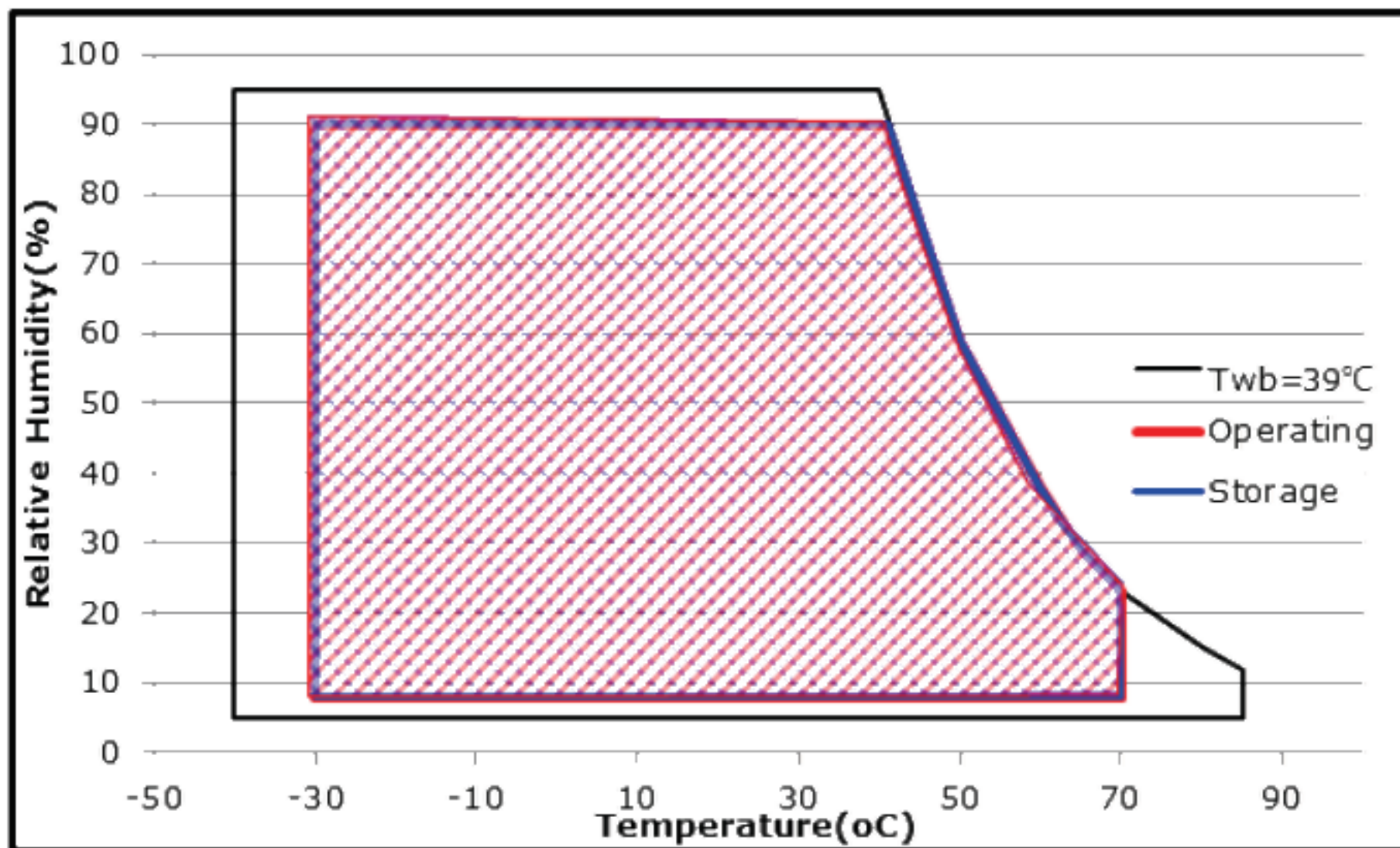

## 5. Electrical Characteristics

### 5.1 TFT LCD Module

#### 5.1.1 Power Specification

Symbol	Parameter	Min.	Typ.	Max.	Units	Remark
VDD	Logic/LCD Drive Voltage	3.0	3.3	3.6	[Volt]	±10%
IDD	VDD Current	-	0.42	0.51	[A]	All White Pattern (VDD=3.3V, at 60Hz)
Irush	LCD Inrush Current			3	[A]	Note 1
PDD	VDD Power	-	1.39	1.68	[Watt]	All White Pattern (VDD=3.3V, at 60Hz)

Note 1: Measurement condition:

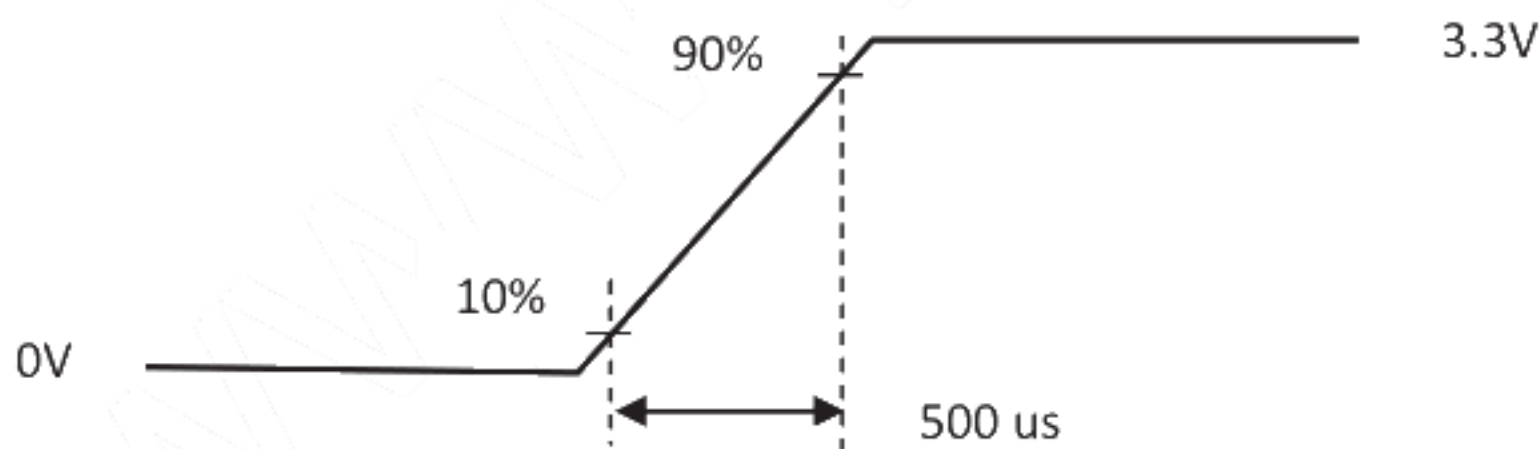
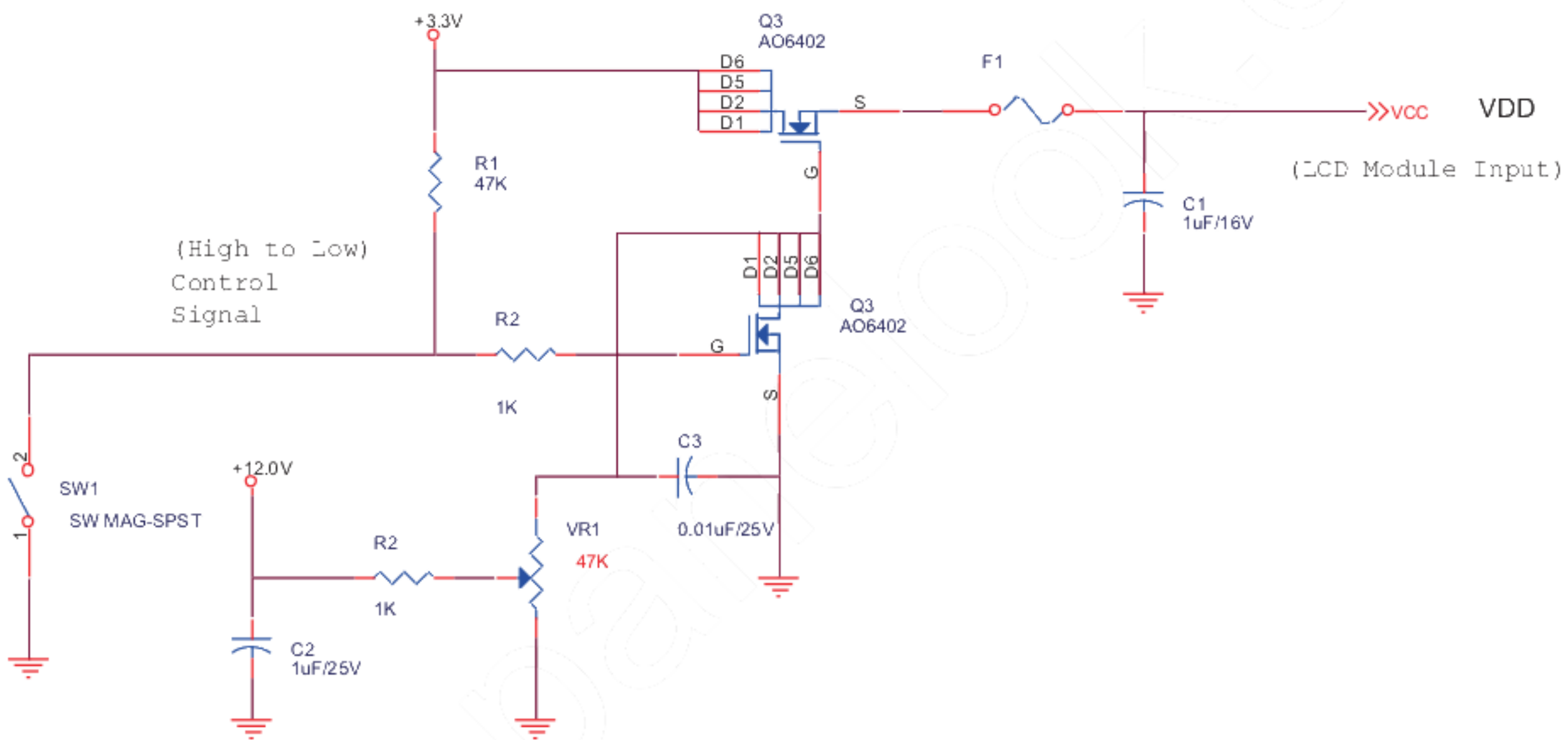

VDD rising time

**5.1.2 Signal Electrical Characteristics**

Symbol	Item	Min.	Typ.	Max.	Unit	Remark
VTH	Differential Input High Threshold	-	-	100	[mV]	VCM=1.2V
VTL	Differential Input Low Threshold	-100	-	-	[mV]	VCM=1.2V
VID	Input Differential Voltage	100		600	[mV]	
VICM	Differential Input Common Mode Voltage	1.0	1.2	1.5	[V]	VTH/VTL=±100mV

Input signals shall be low or Hi-Z state when VDD is off.

Note: LVDS Signal Waveform.

$V_P - V_N = |VID| > V_{TH} = \text{"High"}$   
 $V_P - V_N = -|VID| < V_{TL} = \text{"Low"}$

**Single-end Signal**

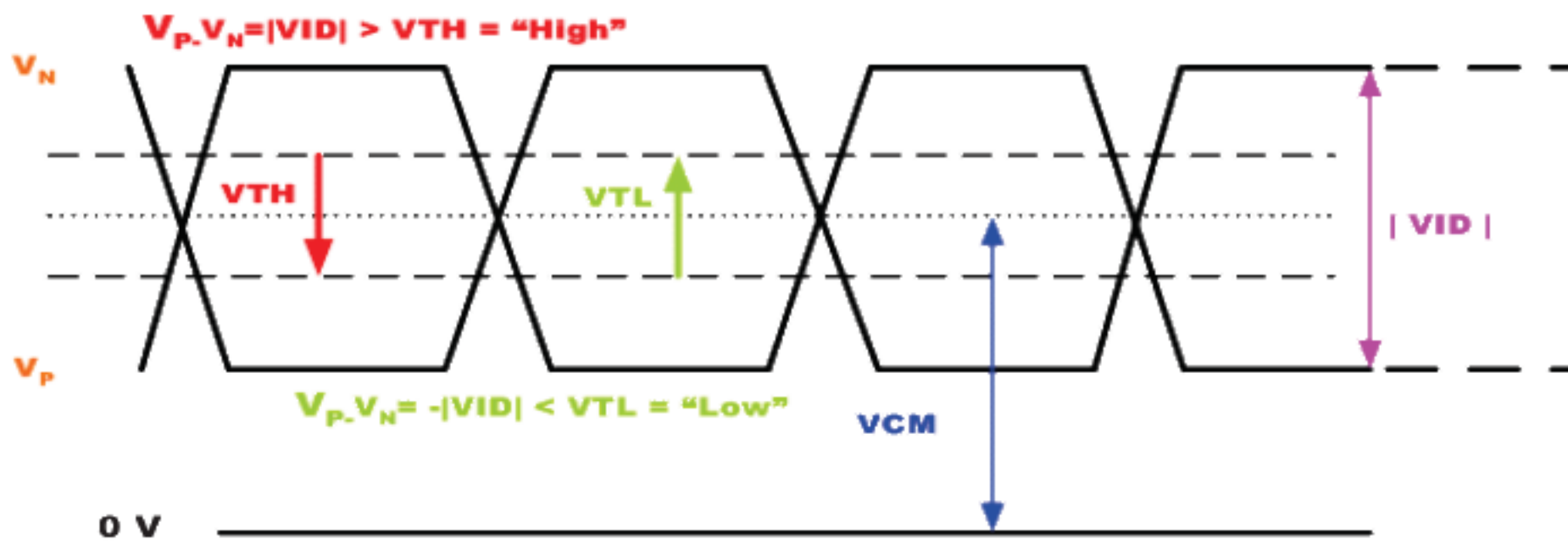

**Differential Signal**

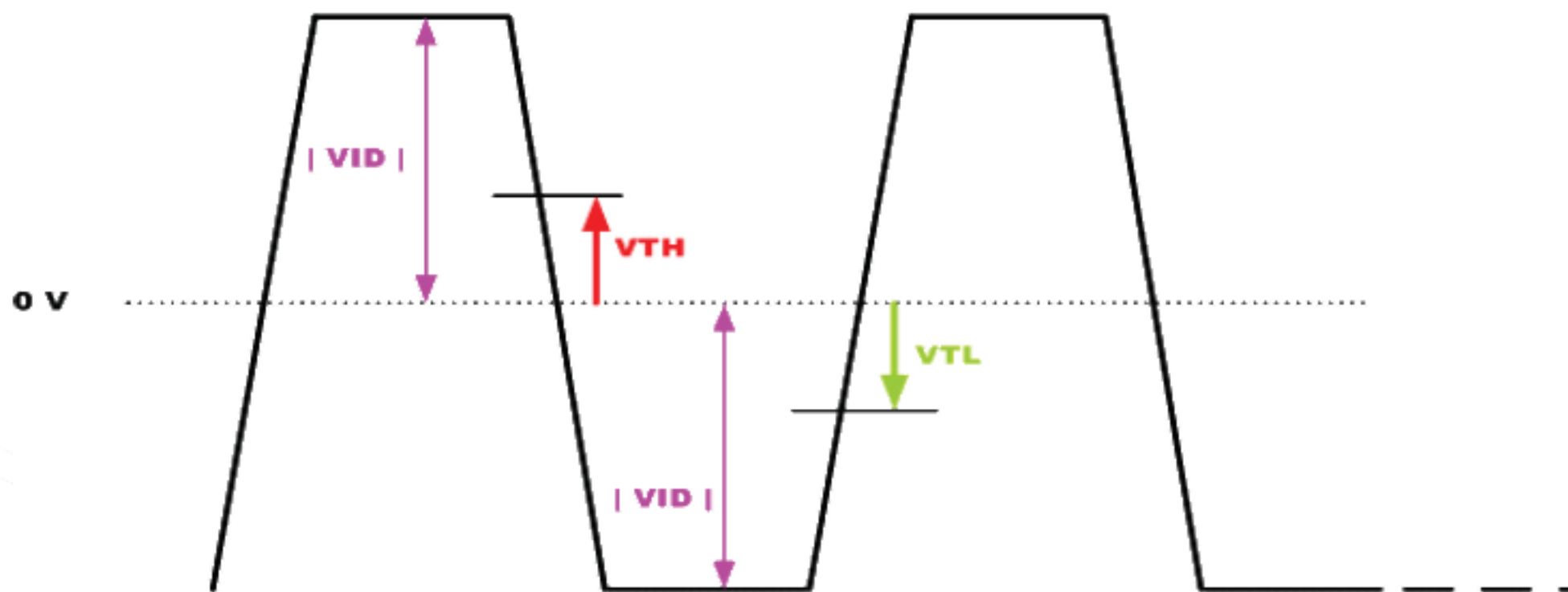

## 5.2 Backlight Unit

### 5.2.1 Parameter guideline for LED

Following characteristics are measured under stable condition using a LED driving board at 25°C (Room Temperature).

Symbol	Parameter	Min.	Typ.	Max.	Unit	Remark
Vcc	Input Voltage	22.8	24	25.2	Volt	
Ivcc	Input Current	-	0.894	1.035	A	100% Dimming
PLED	Power Consumption	-	21.45	23.60	Watt	100% Dimming
Irush	Inrush Current		-	2.07	A	
VLED on/off	On Control Voltage	2.5	-	-	Volt	
	Off Control Voltage	-	-	0.5	Volt	
FPWM	PWM Dimming Frequency	200		20k	Hz	
	High Voltage	2.5	-	-	Volt	
	Low Voltage	-	-	0.5	Volt	
	Dimming Duty Cycle, 200Hz~5KHz	5	-	100	%	
	Dimming Duty Cycle, 5KHz~20KHz	15	-	100	%	
I <sub>F</sub>	LED Forward Current		65		mA	Ta = 25°C
Operating Life		50,000			Hrs	Ta = 25°C

Note 1: Ta means ambient temperature of TFT-LCD module.

Note 2: If G150XAN02.2 module is driven at high ambient temperature & humidity condition. The operating life will be reduced.

Note 3: Definition of life time: LED brightness becomes 50% of its original value. The minimum life time of LED unit is defined at the condition of I<sub>LED</sub> = 65 mA and 25±2°C (Room temperature).

## 6. Signal Characteristic

### 6.1 Pixel Format Image

Following figure shows the relationship between input signal and LCD pixel format.

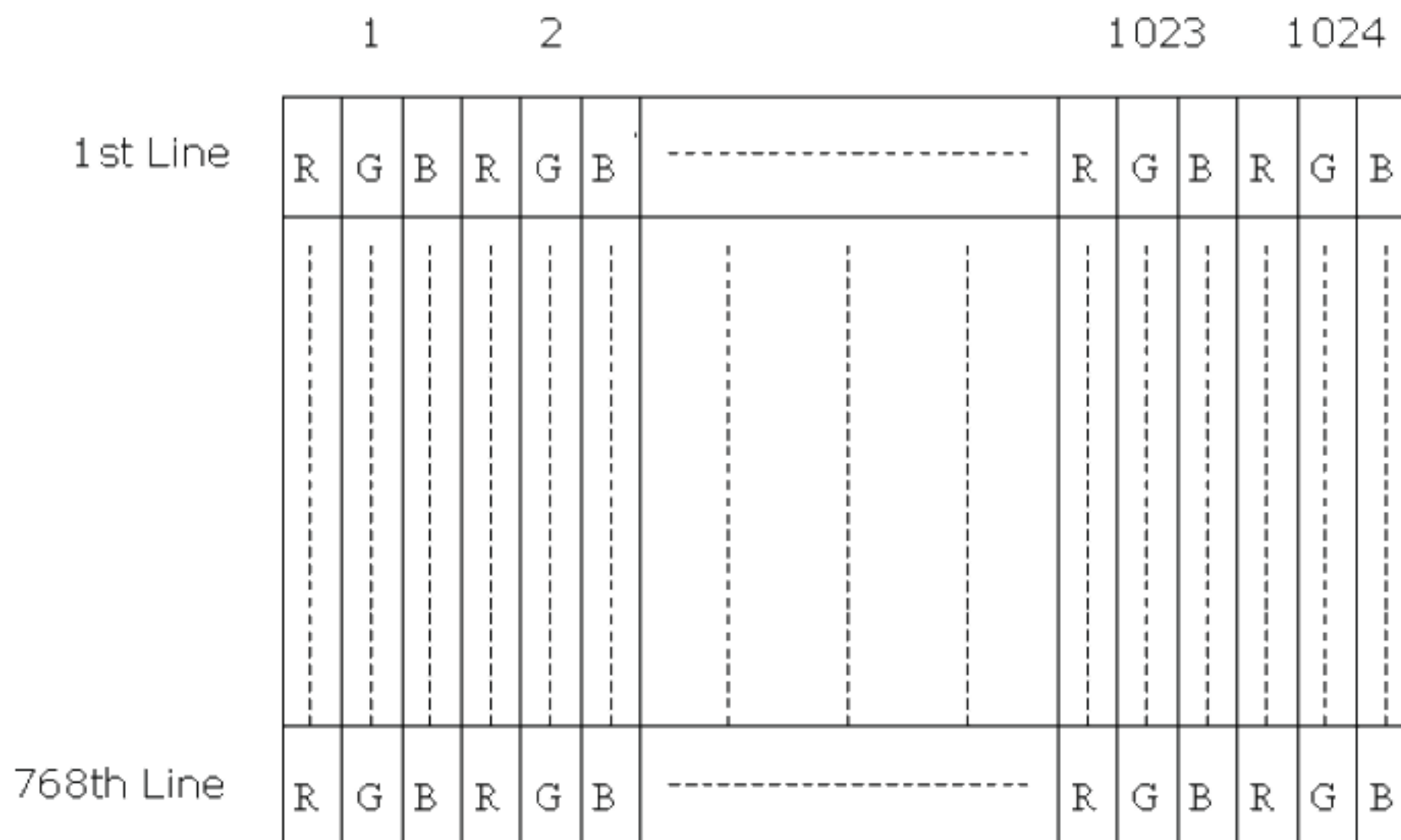

### 6.2 Scanning Direction

The following figures show the image seen from the front view. The arrow indicates the direction of scan.



## 6.3 Signal Description

LVDS is a differential signal technology for LCD interface and high speed data transfer device.

Pin No.	Symbol	Description
1	VDD	Power Supply, 3.3V (typical)
2	VDD	Power Supply, 3.3V (typical)
3	NC	No Connect
4	NC	No Connect
5	Rin1-	- LVDS differential data input (R0-R5, G0)
6	Rin1+	+ LVDS differential data input (R0-R5, G0)
7	VSS	Ground
8	Rin2-	- LVDS differential data input (G1-G5, B0-B1)
9	Rin2+	+ LVDS differential data input (G1-G5, B0-B1)
10	VSS	Ground
11	Rin3-	- LVDS differential data input (B2-B5, HS, VS, DE)
12	Rin3+	+ LVDS differential data input (B2-B5, HS, VS, DE)
13	VSS	Ground
14	ClkIN-	- LVDS differential clock input
15	ClkIN+	+ LVDS differential clock input
16	GND	Ground
17	Rin4-	- LVDS differential data input (R6-R7, G6-G7, B6-B7)
18	Rin4+	+ LVDS differential data input (R6-R7, G6-G7, B6-B7)
19	VSS	Ground
20	VSS	Ground

Note 1: Input signals shall be in low status when VDD is off.

## 6.4 The Input Data Format

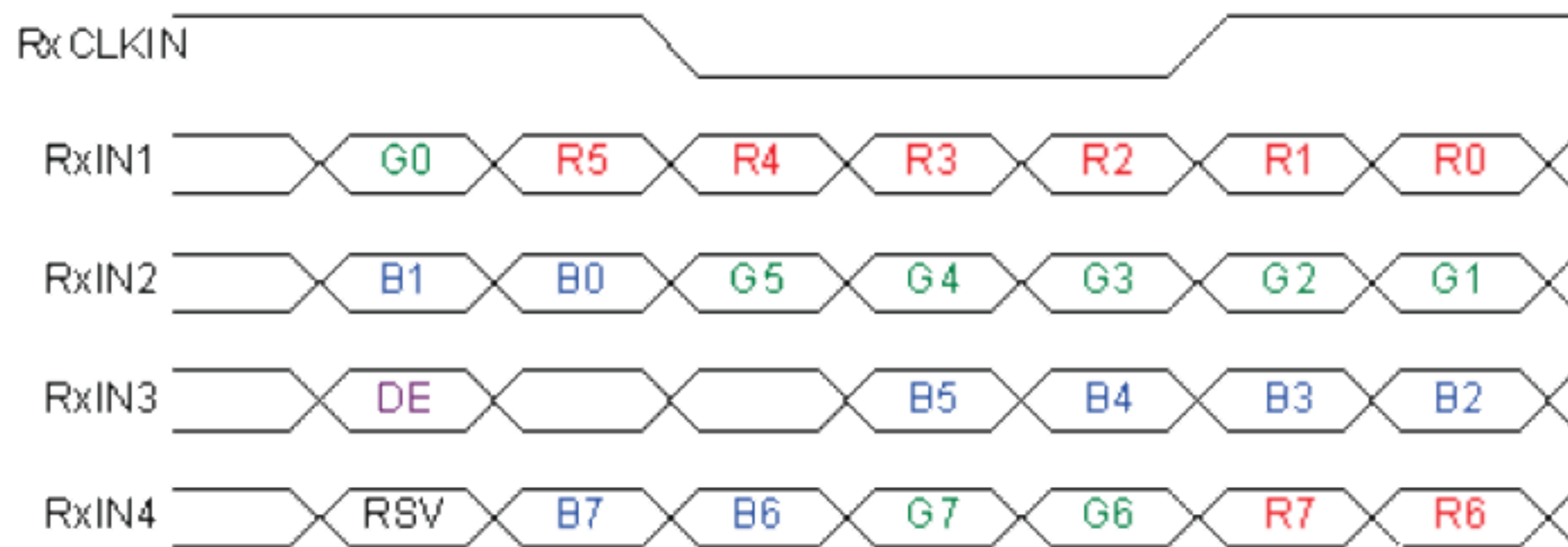

**Note1:** Please follow PSWG.

**Note2:** R/G/B data 7:MSB, R/G/B data 0:LSB

Signal Name	Description	Remark
R7 R6 R5 R4 R3 R2 R1 R0	Red Data 7 Red Data 6 Red Data 5 Red Data 4 Red Data 3 Red Data 2 Red Data 1 Red Data 0	Red-pixel Data  For 8Bits LVDS input MSB: R7 ; LSB: R0
G7 G6 G5 G4 G3 G2 G1 G0	Green Data 7 Green Data 6 Green Data 5 Green Data 4 Green Data 3 Green Data 2 Green Data 1 Green Data 0	Green-pixel Data  For 8Bits LVDS input MSB: G7 ; LSB: G0
B7 B6 B5 B4 B3 B2 B1 B0	Blue Data 7 Blue Data 6 Blue Data 5 Blue Data 4 Blue Data 3 Blue Data 2 Blue Data 1 Blue Data 0	Blue-pixel Data  For 8Bits LVDS input MSB: B7 ; LSB: B0
RxCLKIN	LVDS Data Clock	
DE	Data Enable Signal	When the signal is high, the pixel data shall be valid to be displayed.

Note: Output signals from any system shall be low or Hi-Z state when VDD is off.



## 6.5 Interface Timing

### 6.5.1 Timing Characteristics

Signal	Parameter	Symbol	Min.	Typ.	Max.	Unit	
Clock Timing	Clock frequency	$1/T_{\text{Clock}}$	63	65	67	MHz	
Vsync Timing	Vertical Section	Period	$T_V$	804	806	808	$T_{\text{Line}}$
		Active	$T_{VD}$	768	768	768	
		Blanking	$T_{VB}$	36	38	40	
Hsync Timing	Horizontal Section	Period	$T_H$	1328	1344	1360	$T_{\text{Clock}}$
		Active	$T_{HD}$	1024	1024	1024	
		Blanking	$T_{HB}$	304	320	336	
Frame Rate		F	59	60	61	Hz	

Note: Support DE mode only.

Note : Typical value refer to VESA STANDARD

### 6.5.2 Input Timing Diagram

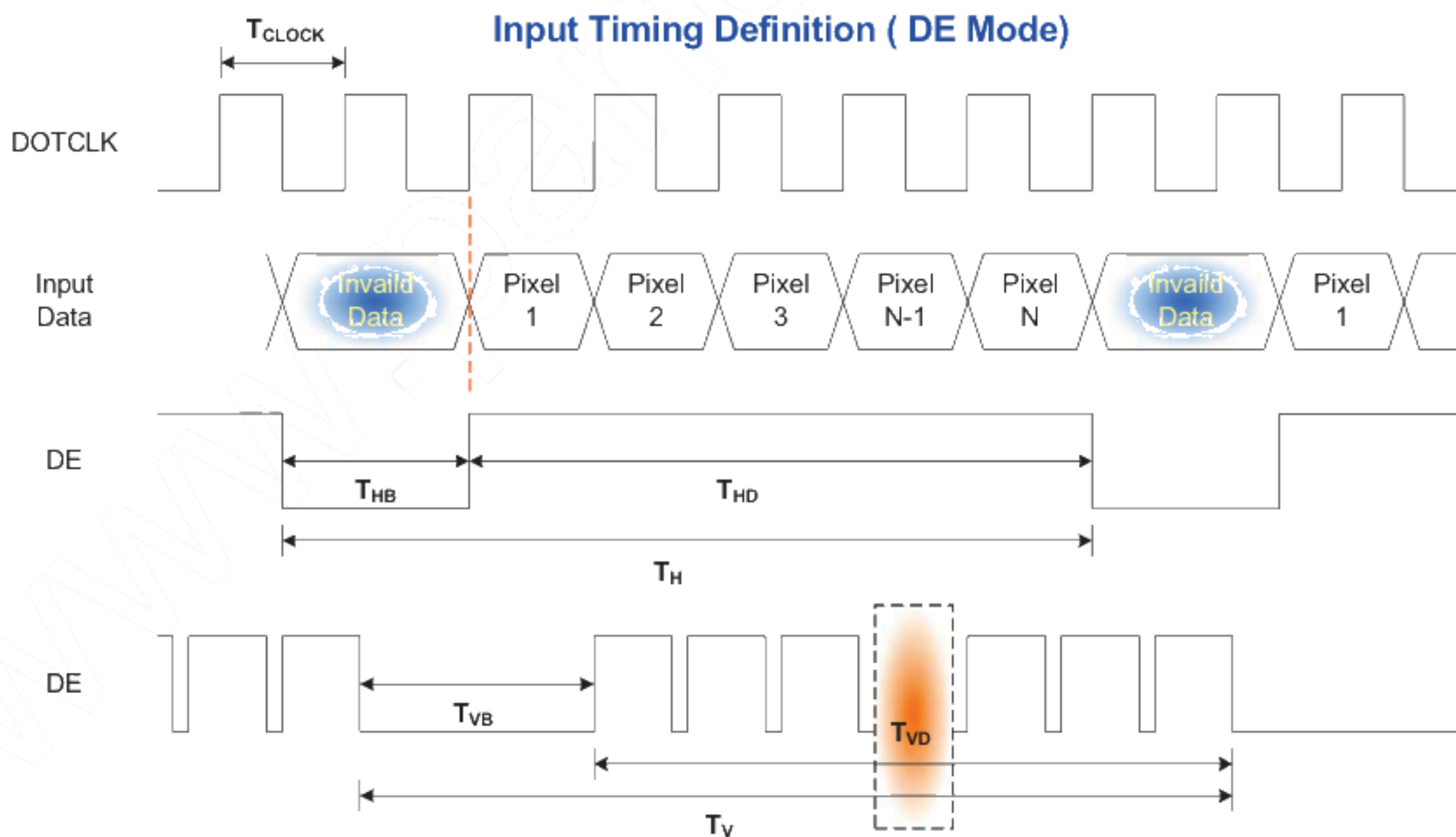

## 6.6 Power ON/OFF Sequence

VDD power and backlight on/off sequence is as below. Interface signals are also shown in the chart. Signals from any system shall be Hi-Z state or low level when VDD is off.

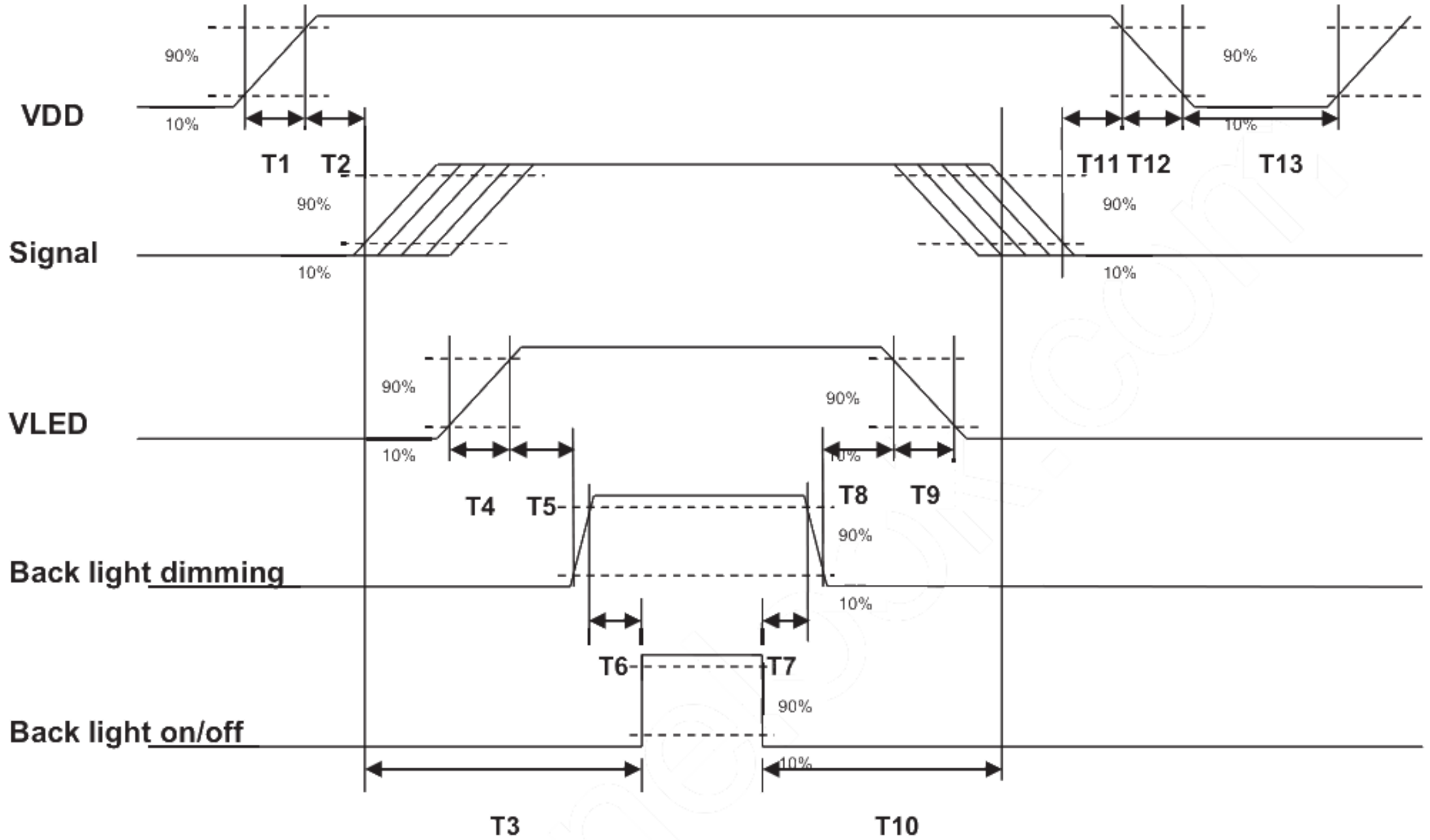

Power Sequence Timing

Parameter	Value			Unit
	Min.	Typ.	Max.	
T1	0.5	-	10	[ms]
T2	30	40	50	[ms]
T3	200	-	-	[ms]
T4	0.5	-	10	[ms]
T5	10	-	-	[ms]
T6	10	-	-	[ms]
T7	0	-	-	[ms]
T8	10	-	-	[ms]
T9	-	-	200	[ms]
T10	110	-	-	[ms]
T11	0	16	50	[ms]
T12	-	-	200	[ms]
T13	1000	-	-	[ms]

The above on/off sequence should be applied to avoid abnormal function in the display. Please make sure to turn off the power when you plug the cable into the input connector or pull the cable out of the connector.

## 7. Connector & Pin Assignment

Physical interface is described as for the connector on module. These connectors are capable of accommodating the following signals and will be following components.

### 7.1 TFT LCD Module: LVDS Connector

Connector Name / Designation	Signal Connector
Manufacturer	STM or compatible
Connector Model Number	MSB240420HD or compatible
Adaptable Plug	P240420 or compatible

Pin#	Signal Name	Pin#	Signal Name
1	VDD	2	VDD
3	NC	4	NC
5	Rin1-	6	Rin1+
7	VSS	8	Rin2-
9	Rin2+	10	VSS
11	Rin3-	12	Rin3+
13	VSS	14	ClkIN-
15	ClkIN+	16	GND
17	Rin4-	18	Rin4+
19	VSS	20	VSS

#### 7.1.1 Connector Illustration

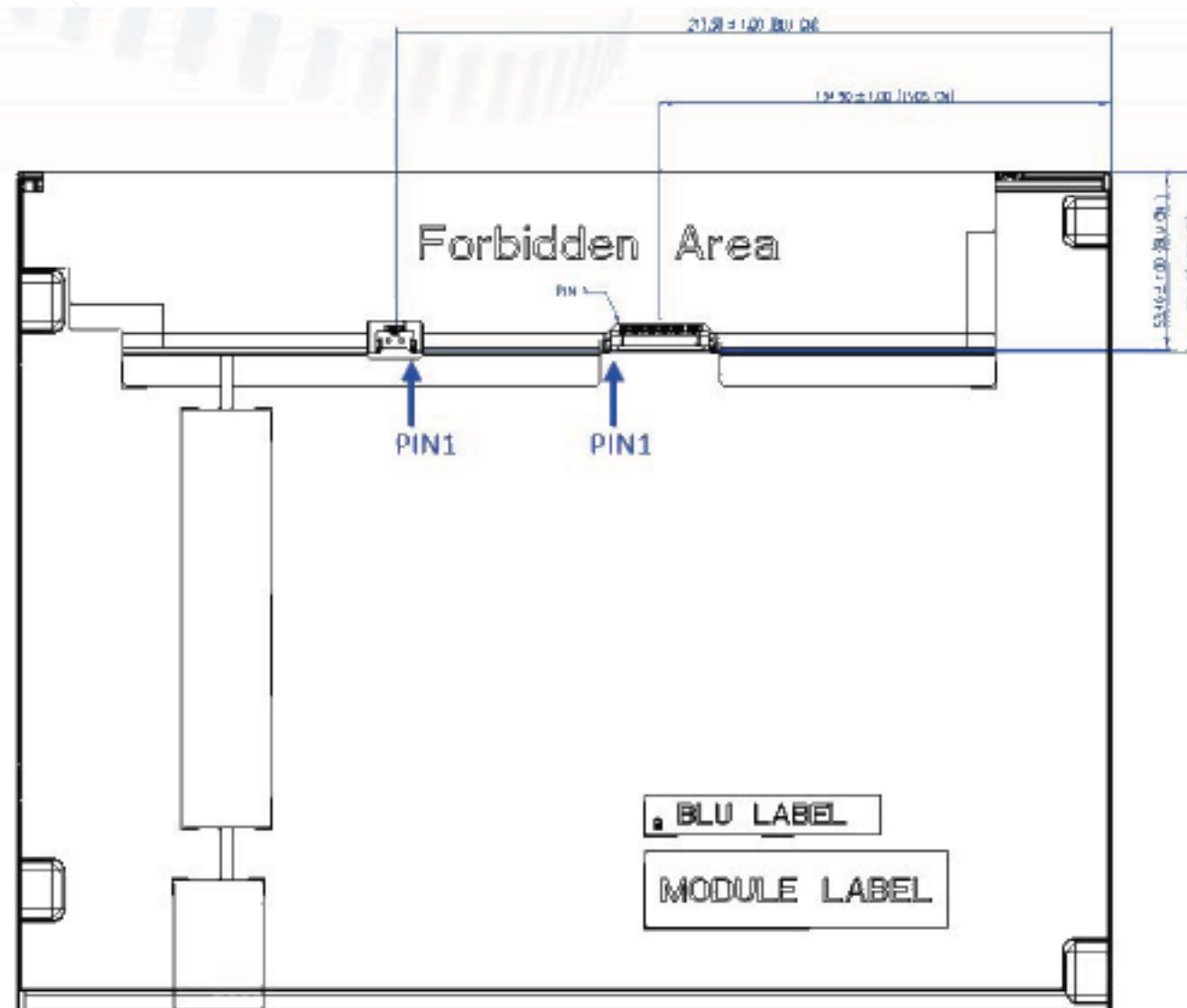

## 7.2 LED Backlight Unit: LED Driver Connector

Connector Name / Designation	LED Connector
Manufacturer	Entery or STM or compatible
Connector Model Number	3808K-F05N-12R or MSB24038P5D or compatible
Mating Model Number	H208K-P05N-02B or P24038P5 or compatible

## 7.3 LED Driver Connector Pin Assignment

Pin#	Symbol	Signal Name
1	Vcc	24V
2	GND	GND
3	Enable	VLED On/Off
4	Dimming	PWM Dimming
5	NC	NC

## 8. Reliability Test Criteria

Items	Required Condition	Note
Temperature Humidity Bias	50°C/80%, 300 hours	
High Temperature Operation	70°C, 300 hours	
Low Temperature Operation`	-30°C, 300 hours	
Hot Storage	70°C, 300 hours	
Cold Storage	-30°C, 300 hours	
Thermal Shock Test	-20°C/30 min, 60°C/30 min, 100cycles	
Shock Test (Non-Operating)	50G, 20ms, Half-sine wave, ( $\pm X, \pm Y, \pm Z$ )	
Vibration Test (Non-Operating)	1.5G, (10~200Hz, P-P), 30 mins/axis (X, Y, Z)	
On/off test	On/10 sec, Off/10 sec, 30,000 cycles	
ESD	Contact Discharge: $\pm 8KV, 150pF(330\Omega)$ 1sec, 8 points, 25 times/ point Air Discharge: $\pm 15KV, 150pF(330\Omega)$ 1sec, 8 points, 25 times/ point	Note 1

Note 1: According to EN61000-4-2, ESD class B: Some performance degradation allowed. No data lost Self-recoverable. No hardware failures.

Remark:

- Water condensation is not allowed for each test items.
- Each test is done by new TFT-LCD module. Don't use the same TFT-LCD module repeatedly for reliability test.
- The reliability test is performed only to examine the TFT-LCD module capability.
- To inspect TFT-LCD module after reliability test, please store it at room temperature and room humidity for 24 hours at least in advance.
- No function failure occurs. Mura shall be ignored after high temperature reliability test.
- 70°C is panel surface temperature at High Temperature Operation test.

## 9. Mechanical Characteristics

### 9.1 LCM Outline Dimension (Front View)

NOTES:  
 1. USERHOLE: Ø=M2, USERHOLE: SIDE HOLE: Ø=M1.5MM, 4kg±0.1mm, 4kg±0.1mm AND M2-SCREW \*C: TIMES  
 2. UNSPECIFIED TOLERANCE TO BE ±0.5mm.

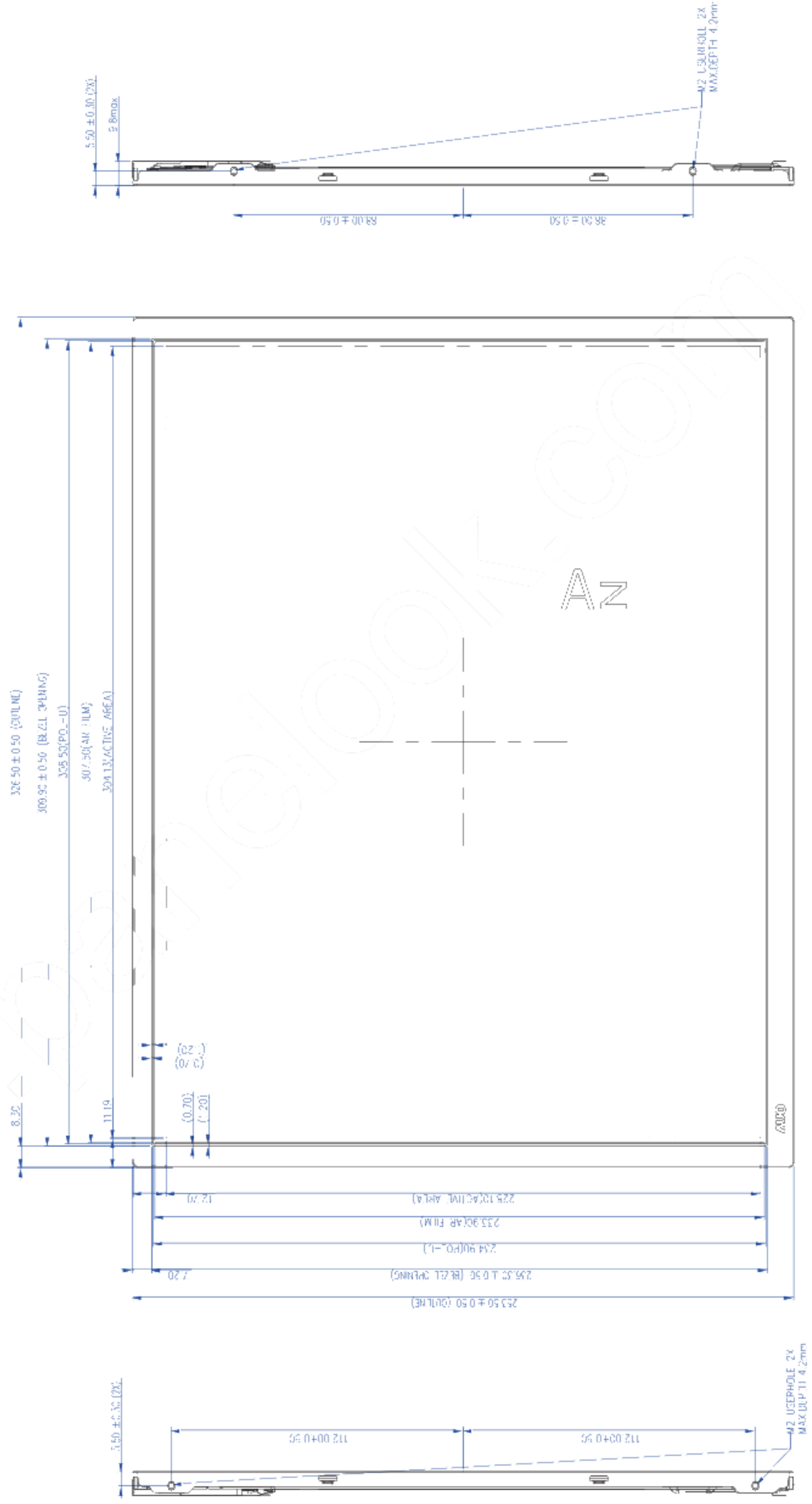

**9.2 LCM Outline Dimension (Rear View)**

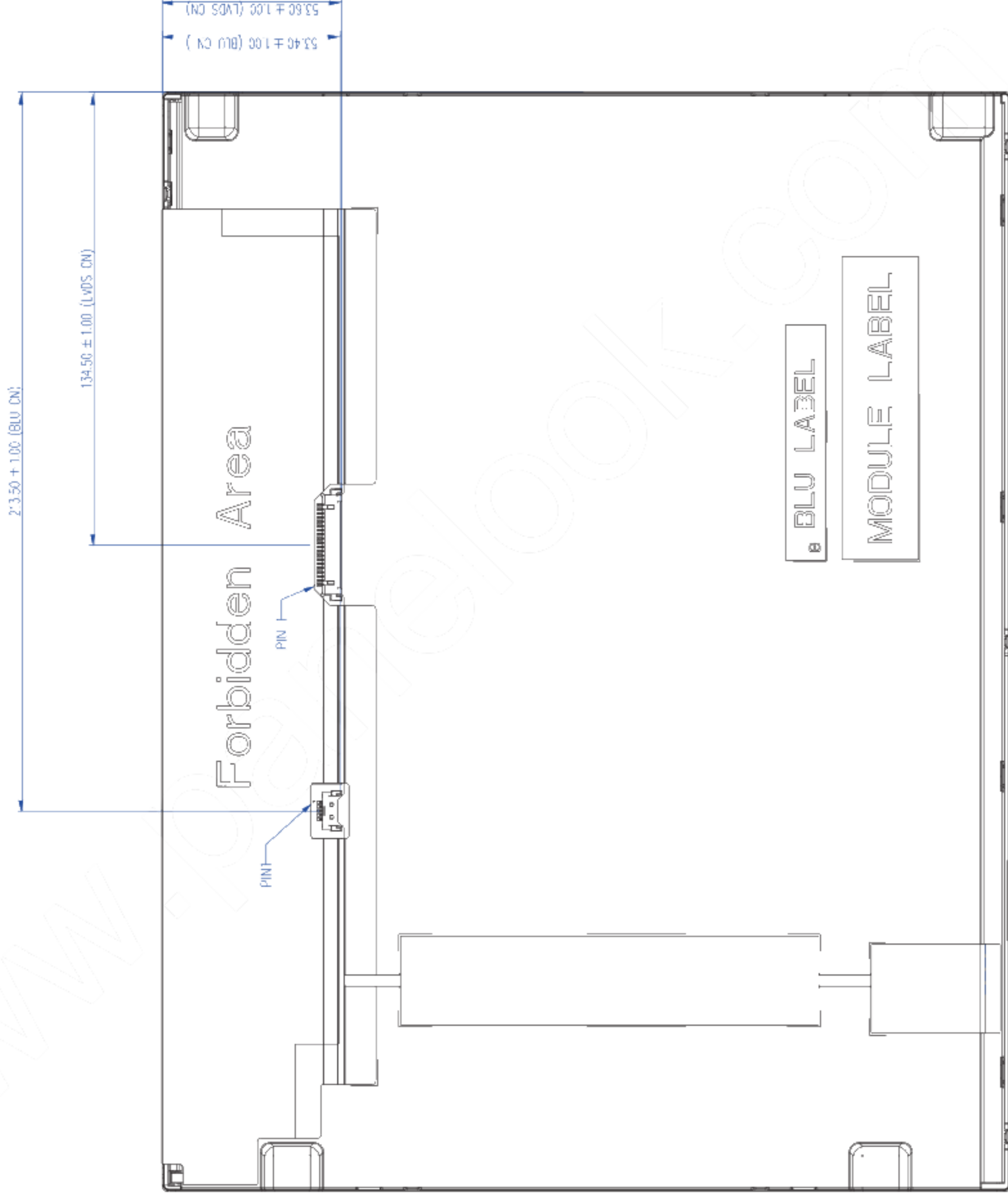

**10. Label and Packaging**

**10.1 Shipping Label** (on the rear side of TFT-LCD display)

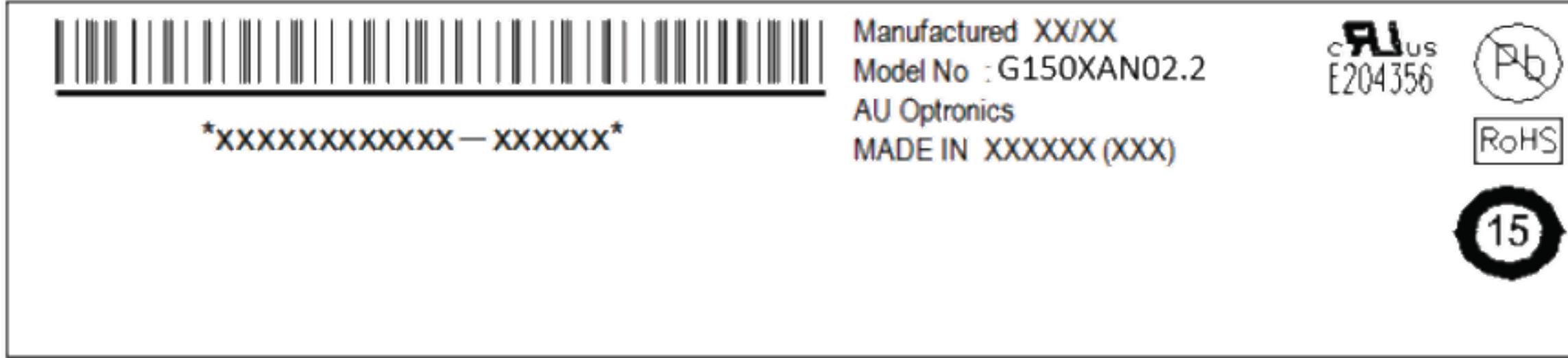

**10.2 Carton Package**

Max capacity : 14 TFT-LCD module per carton  
 Max weight: 16 kg per carton  
 Outside dimension of carton: 430mm(L)\* 370mm(W)\*350mm(H)  
 Pallet size : 1150 mm \* 910 mm \* 132mm

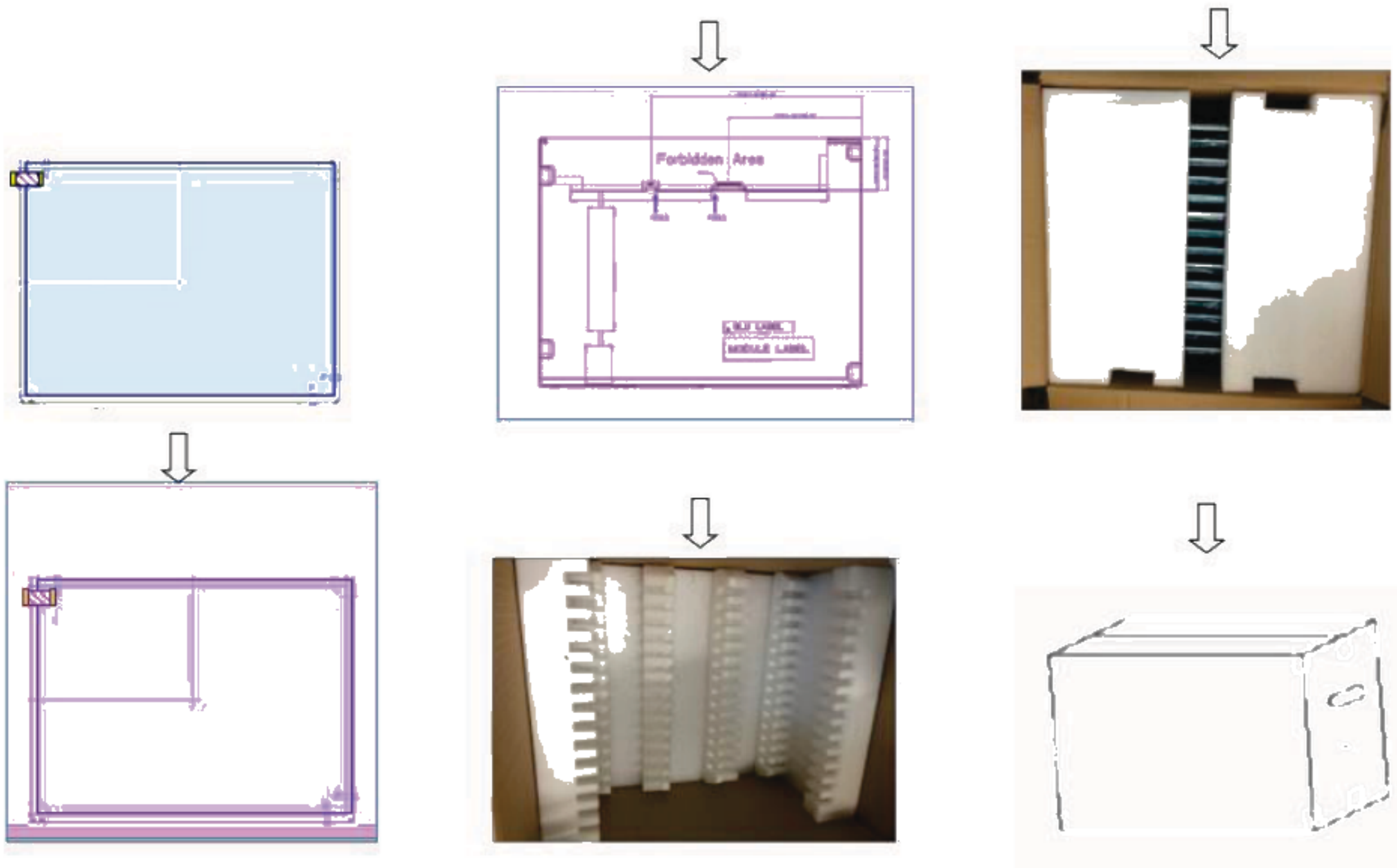

14pcs/Carton



### 10.3 Palletizing

Module by air\_ Max:  $(2 * 3) * 4$  layers , one pallet put 24 boxes , total 336pcs module

Module by sea\_ Max:  $(2 * 3) * 4$  layers +  $(2 * 3) * 1$  layers , two pallet put 30 boxes , total 420pcs module

Module by sea\_ HQ\_ Max:  $(2 * 3) * 4$  layers+ $(2 * 3) * 2$  layers, two pallet put 36 boxes, total 504pcs module

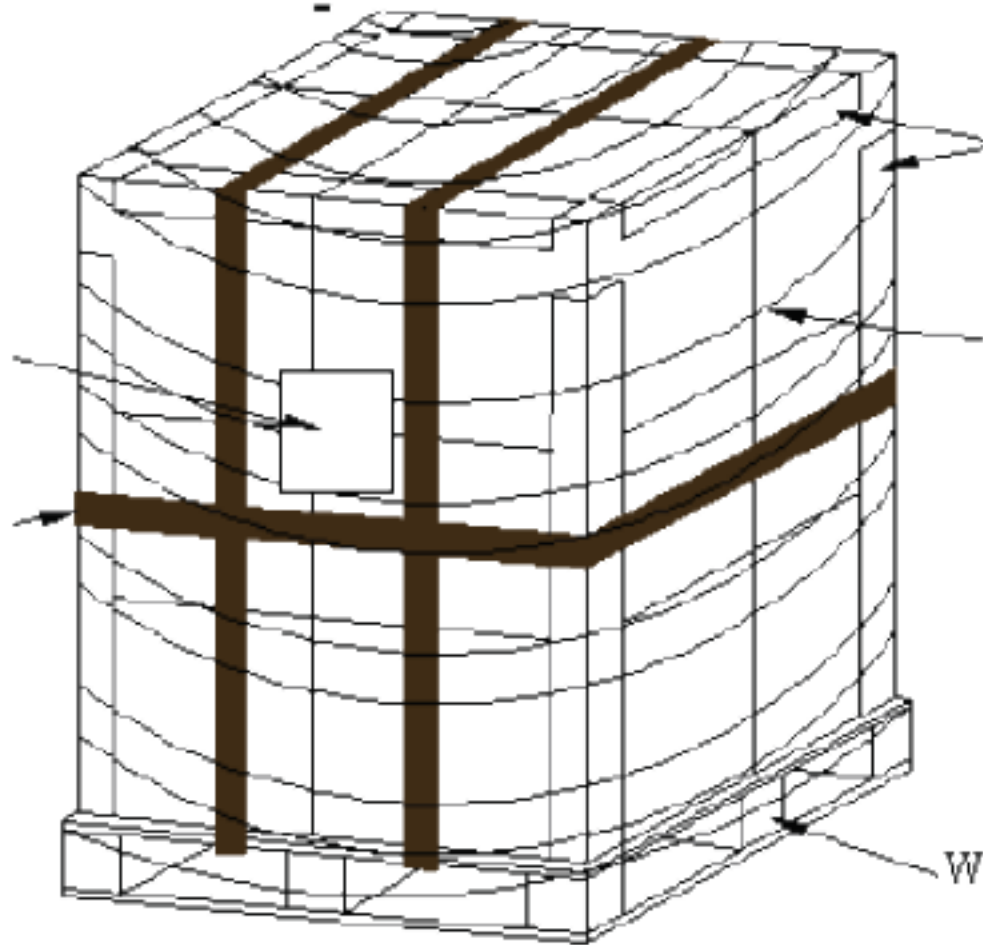

單層 pallet 打棧示意圖

By air : one pallet

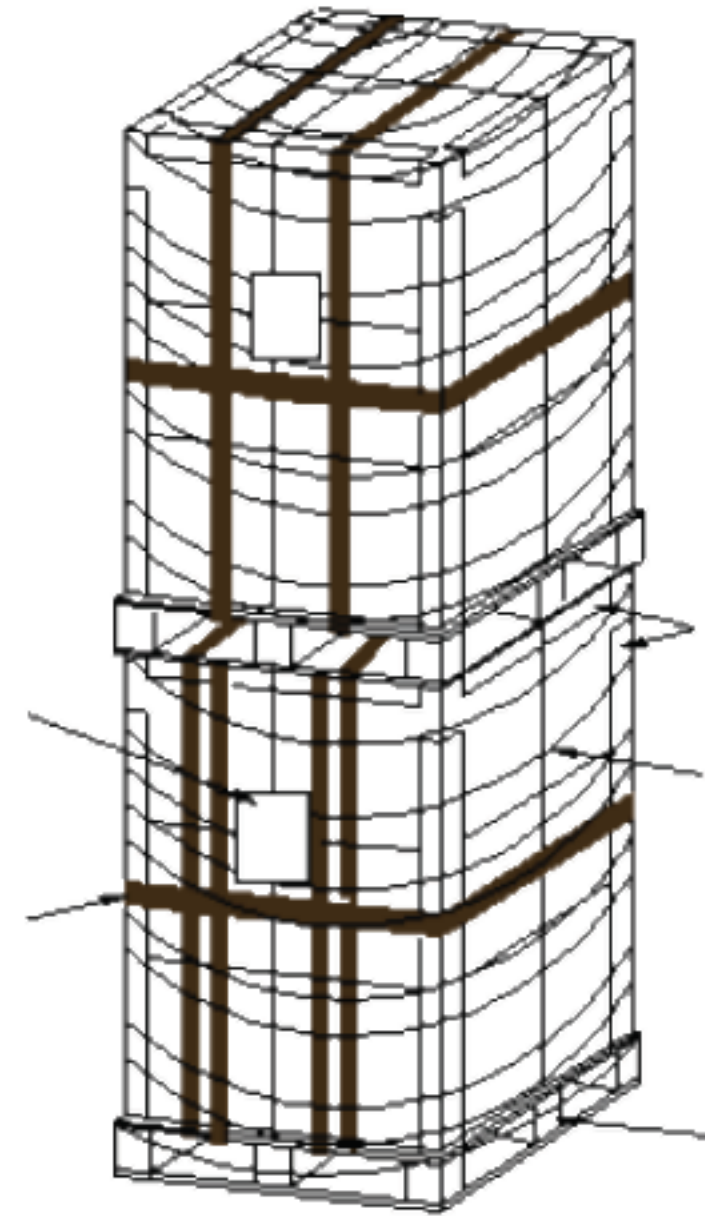

By sea : two pallet

## **11 Safety**

### **11.1 Sharp Edge Requirements**

There will be no sharp edges or comers on the display assembly that could cause injury.

### **11.2 Materials**

#### **11.2.1 Toxicity**

There will be no carcinogenic materials used anywhere in the display module. If toxic materials are used, they will be reviewed and approved by the responsible AUO toxicologist.

#### **11.2.2 Flammability**

All components including electrical components that do not meet the flammability grade UL94-V1 in the module will complete the flammability rating exception approval process.

The printed circuit board will be made from material rated 94-V1 or better. The actual UL flammability rating will be printed on the printed circuit board.

### **11.3 Capacitors**

If any polarized capacitors are used in the display assembly, provisions will be made to keep them from being inserted backwards.

### **11.4 National Test Lab Requirement**

The display module will satisfy all requirements for compliance to:

UL 60950-1, Second Edition

U.S.A. Information Technology Equipment