



**(V) Preliminary Specifications**  
**( ) Final Specifications**

|                   |                       |
|-------------------|-----------------------|
| <b>Module</b>     | 15 Inch Color TFT-LCD |
| <b>Model Name</b> | G150XTN03.8           |

| <b>Customer</b>                  | <b>Date</b> | <b>Approved by</b>  | <b>Date</b>     |
|----------------------------------|-------------|---|-----------------|
| _____                            | _____       | <u>Sean Lin</u>   | <u>2017/8/2</u> |
| <b>Checked &amp; Approved by</b> |             | <b>Prepared by</b>  |                 |
| _____                            | _____       | <u>JasonHsieh</u>   | <u>2017/8/2</u> |
|                                  |             | General Display Business Unit /<br>AU Optronics corporation |                 |

**Contents**

|   |           |
|---|-----------|
| <b>1. Operating Precautions .....</b>                           | <b>4</b>  |
| <b>2. General Description .....</b>                             | <b>5</b>  |
| 2.1 Display Characteristics.....                                | 5         |
| 2.2 Optical Characteristics .....                               | 6         |
| <b>3. Functional Block Diagram .....</b>                        | <b>9</b>  |
| <b>4. Absolute Maximum Ratings.....</b>                         | <b>10</b> |
| 4.1 Absolute Ratings of TFT LCD Module.....                     | 10        |
| 4.2 Absolute Ratings of Environment.....                        | 10        |
| 5.1 TFT LCD Module.....   | 11        |
| 5.2 Backlight Unit.....   | 13        |
| <b>6. Signal Characteristic.....</b>                            | <b>15</b> |
| 6.1 Pixel Format Image .....                                    | 15        |
| 6.2 Scanning Direction.....                                     | 15        |
| 6.3 Signal Description .....                                    | 16        |
| 6.4 Power ON/OFF Sequence .....                                 | 17        |
| <b>7. Integration Interface Requirement .....</b>               | <b>20</b> |
| 7.1 Connector Description.....                                  | 20        |
| <b>8. Reliability Test Criteria.....</b>                        | <b>23</b> |
| <b>9. Mechanical Characteristics .....</b>                      | <b>24</b> |
| 9.1 LCM Outline Dimension (Front View).....                     | 24        |
| 9.2 LCM Outline Dimension (Rear View) .....                     | 25        |
| <b>10. Label and Packaging.....</b>                             | <b>26</b> |
| 10.1 Shipping Label (on the rear side of TFT-LCD display) ..... | 26        |
| 10.2 Carton Package .....                                       | 26        |
| 10.3 Palletizing.....   | 27        |
| <b>11 Safety .....</b>  | <b>27</b> |
| 11.1 Sharp Edge Requirements .....                              | 28        |
| 11.2 Materials.....   | 28        |
| 11.3 Capacitors .....   | 28        |
| 11.4 National Test Lab Requirement .....                        | 28        |



**Record of Revision**

| Version and Date | Page | Old description | New Description |
|------------------|------|-----------------|-----------------|
| 0.0 2017/6/7     | All  | First Edition   |                 |
|                  |      |                 |                 |
|                  |      |                 |                 |
|                  |      |                 |                 |
|                  |      |                 |                 |
|                  |      |                 |                 |
|                  |      |                 |                 |
|                  |      |                 |                 |
|                  |      |                 |                 |
|                  |      |                 |                 |
|                  |      |                 |                 |
|                  |      |                 |                 |
|                  |      |                 |                 |
|                  |      |                 |                 |
|                  |      |                 |                 |

## 1. Operating Precautions

- 1) Since front polarizer is easily damaged, please be cautious and not to scratch it.
- 2) Be sure to turn off power supply when inserting or disconnecting from input connector.
- 3) Wipe off water drop immediately. Long contact with water may cause discoloration or spots.
- 4) When the panel surface is soiled, wipe it with absorbent cotton or soft cloth.
- 5) Since the panel is made of glass, it may be broken or cracked if dropped or bumped on hard surface.
- 6) Since CMOS LSI is used in this module, take care of static electricity and insure human earth when handling.
- 7) Do not open nor modify the module assembly.
- 8) Do not press the reflector sheet at the back of the module to any direction.
- 9) In case if a module has to be put back into the packing container slot after it was taken out from the container, do not press the center of the LED Reflector edge. Instead, press at the far ends of the LED Reflector edge softly. Otherwise the TFT Module may be damaged.
- 10) At the insertion or removal of the Signal Interface Connector, be sure not to rotate nor tilt the Interface Connector of the TFT Module.
- 11) TFT-LCD Module is not allowed to be twisted & bent even force is added on module in a very short time. Please design your display product well to avoid external force applying to module by end-user directly.
- 12) Small amount of materials without flammability grade are used in the TFT-LCD module. The TFT-LCD module should be supplied by power complied with requirements of Limited Power Source (IEC60950-1 or UL60950-1), or be applied exemption.
- 13) Severe temperature condition may result in different luminance, response time.
- 14) Continuous operating TFT-LCD Module under high temperature environment may accelerate LED light bar exhaustion and reduce luminance dramatically.
- 15) The data on this specification sheet is applicable when TFT-LCD module is placed in landscape position.
- 16) Continuous displaying fixed pattern may induce image sticking. It's recommended to use screen saver or moving content periodically if fixed pattern is displayed on the screen.

## 2. General Description

G150XTN03.8 is a Color Active Matrix Liquid Crystal Display composed of a TFT-LCD display, a driver circuit, and LED backlight system. The screen format is intended to support 4:3 XGA, 1024(H) x768(V) screen and 6+2FRC(16.2M colors) with LED backlight driving circuit. All input signals are eDP (Embedded DisplayPort) interface compatible. All design rules of this module can correspond to PSWG standard.

G150XTN03.8 is designed for industrial display applications.

### 2.1 Display Characteristics

The following items are characteristics summary on the table under 25 °C condition:

| Items   | Unit         | Specifications   |
|---|--------------|--|
| Screen Diagonal   | [inch]       | 15   |
| Active Area   | [mm]         | 304.128(H) x 228.096(V)                                      |
| Pixels H x V  |              | 1024x3(RGB) x 768  |
| Pixel Pitch   | [mm]         | 0.297 x 0.297  |
| Pixel Arrangement   |              | R.G.B. Vertical Stripe                                       |
| Display Mode  |              | TN, Normally White   |
| Nominal Input Voltage VDD                                 | [Volt]       | 3.3 (Typ.)   |
| Typical Power Consumption                                 | [Watt]       | 9.78   |
| Weight  | [Grams]      | 720g Max.  |
| Physical Size   | [mm]         | 326.5(H) x 253.5(V) x 6.3(D, Typ.)                           |
| Electrical Interface                                      |              | 1 Lane eDP1.2  |
| Surface Treatment   |              | Anti-glare, Hardness 3H                                      |
| Support Color   |              | 16.7M / 262K colors  |
| Temperature Range<br>Operating<br>Storage (Non-Operating) | [°C]<br>[°C] | 0 to +60 (+60 °C as panel surface temperature)<br>-20 to +60 |
| RoHS Compliance   |              | RoHS Compliance  |
| Light Bar Unit  |              | LED, Non-Replaceable   |

## 2.2 Optical Characteristics

The optical characteristics are measured under stable conditions at 25°C (Room Temperature):

| Item  | Unit                 | Conditions                           | Min.     | Typ.     | Max.   | Note    |
|---|----------------------|--------------------------------------|----------|----------|--------|---------|
| White Luminance                             | [cd/m <sup>2</sup> ] |                                      | 320      | 400      | -      | 1       |
| Uniformity                                  | %                    | 9 Points                             | 75       | 80       | -      | 1, 2, 3 |
| Contrast Ratio                              |                      |                                      | 400      | 800      | -      | 4       |
| Cross talk                                  | %                    |                                      | -        | --       | 1.5    | 5       |
| Response Time                               | [msec]               | Rising                               | -        | 5.7      |        | 6       |
|   | [msec]               | Falling                              | -        | 2.3      |        |         |
|   | [msec]               | Raising + Falling                    | -        | 8        |        |         |
| Viewing Angle                               | [degree]             | Horizontal (Right)<br>CR = 10 (Left) | 70       | 80       | -      | 7       |
|   | [degree]             |                                      | 70       | 80       | -      |         |
|   | [degree]             | Vertical (Upper)<br>CR = 10 (Lower)  | 60<br>70 | 70<br>80 | -<br>- |         |
| Color / Chromaticity Coordinates (CIE 1931) |                      | Red x                                | 0.547    | 0.597    | 0.647  |         |
|   |                      | Red y                                | 0.289    | 0.339    | 0.389  |         |
|   |                      | Green x                              | 0.279    | 0.329    | 0.379  |         |
|   |                      | Green y                              | 0.546    | 0.596    | 0.646  |         |
|   |                      | Blue x                               | 0.104    | 0.154    | 0.204  |         |
|   |                      | Blue y                               | 0.003    | 0.053    | 0.103  |         |
|   |                      | White x                              | 0.263    | 0.313    | 0.363  |         |
|   |                      | White y                              | 0.279    | 0.329    | 0.379  |         |
| Color Gamut                                 | %                    |                                      |          | 60       | -      |         |

Note 1: Measurement method

Equipment Pattern Generator, Power Supply, Digital Voltmeter, Luminance meter (SR\_3 or equivalent)

Aperture 1° with 50cm viewing distance

Test Point Center

Environment < 1 lux

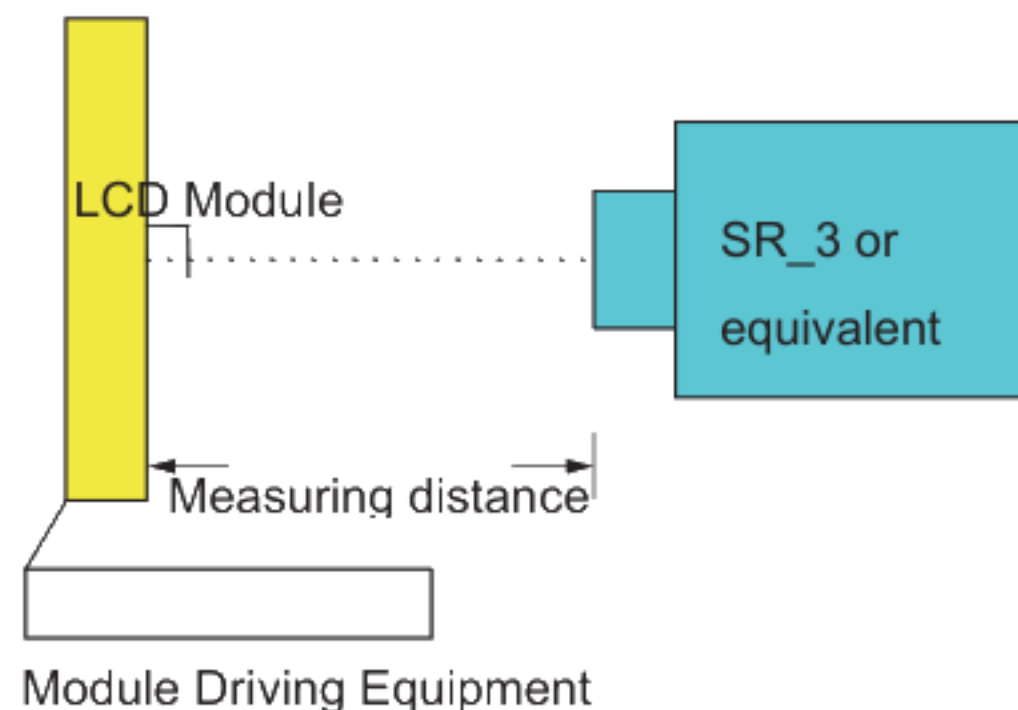

Note 2: Definition of 9 points position (Display active area: 304.128(H) x 228.096(V))

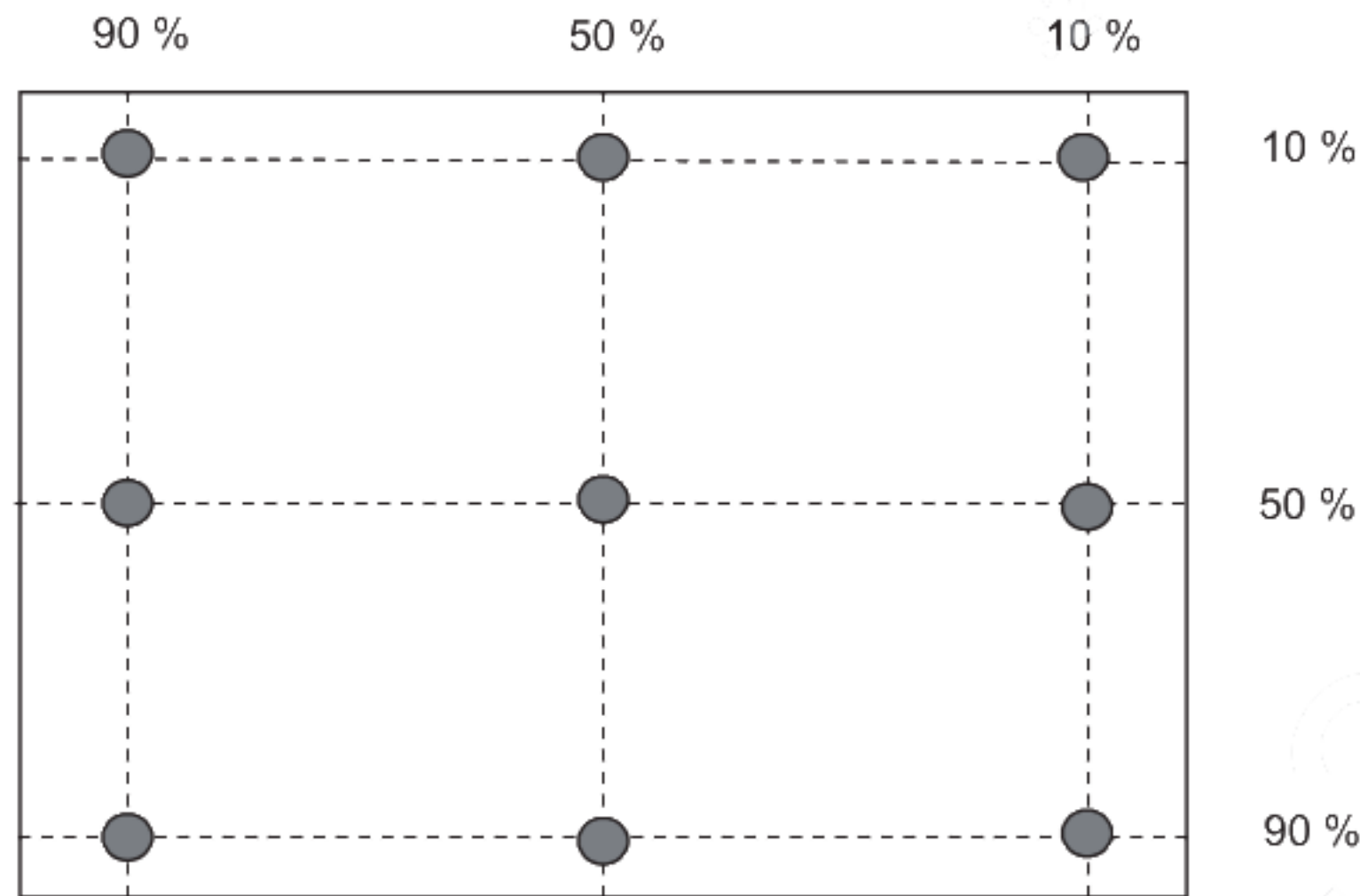

Note 3: The luminance uniformity of 9 points is defined by dividing the minimum luminance values by the maximum test point luminance

$$\delta_{w9} = \frac{\text{Minimum Brightness of nine points}}{\text{Maximum Brightness of nine points}}$$

Note 4 : Definition of contrast ratio (CR):

$$\text{Contrast ratio (CR)} = \frac{\text{Brightness on the "White" state}}{\text{Brightness on the "Black" state}}$$

Note 5 : Definition of cross talk (CT)

$$CT = | YB - YA | / YA \times 100 (\%)$$

Where

YA = Luminance of measured location without gray level 0 pattern (cd/m<sup>2</sup>)

YB = Luminance of measured location with gray level 0 pattern (cd/m<sup>2</sup>)

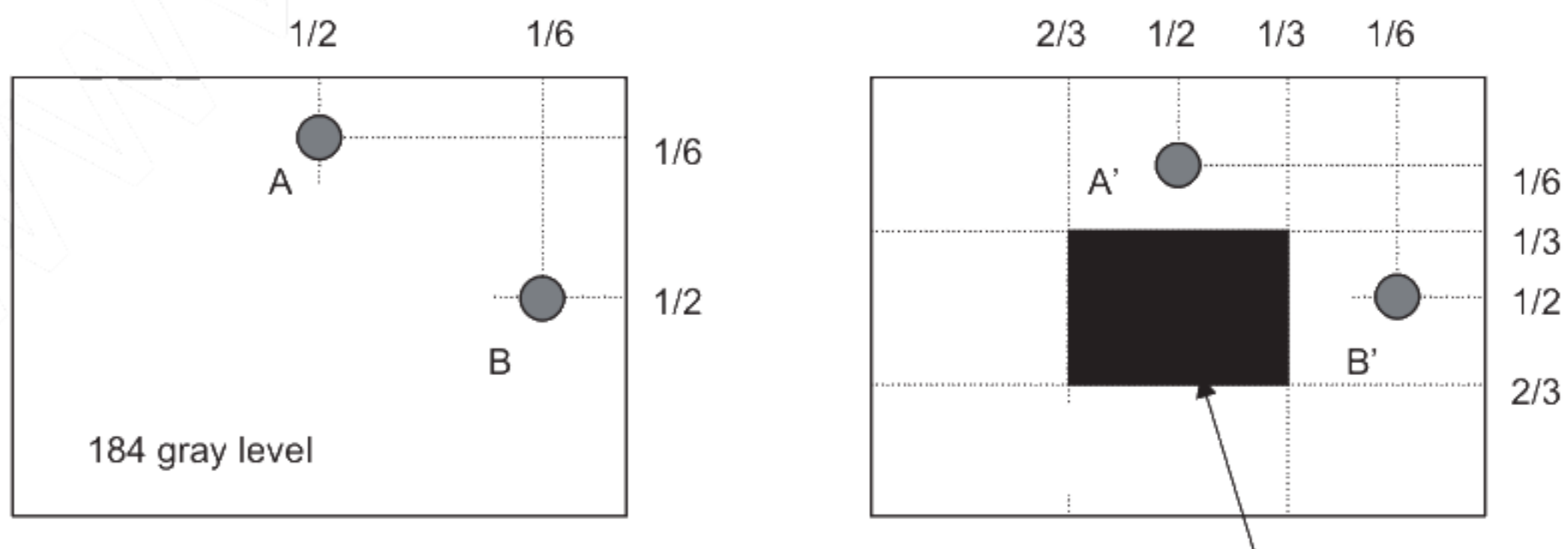

Note 6: Definition of response time:

The output signals of photo detector are measured when the input signals are changed from "White" to "Black" (falling time) and from "Black" to "White" (rising time), respectively. The response time interval is between 10% and 90% of amplitudes. Please refer to the figure as below.

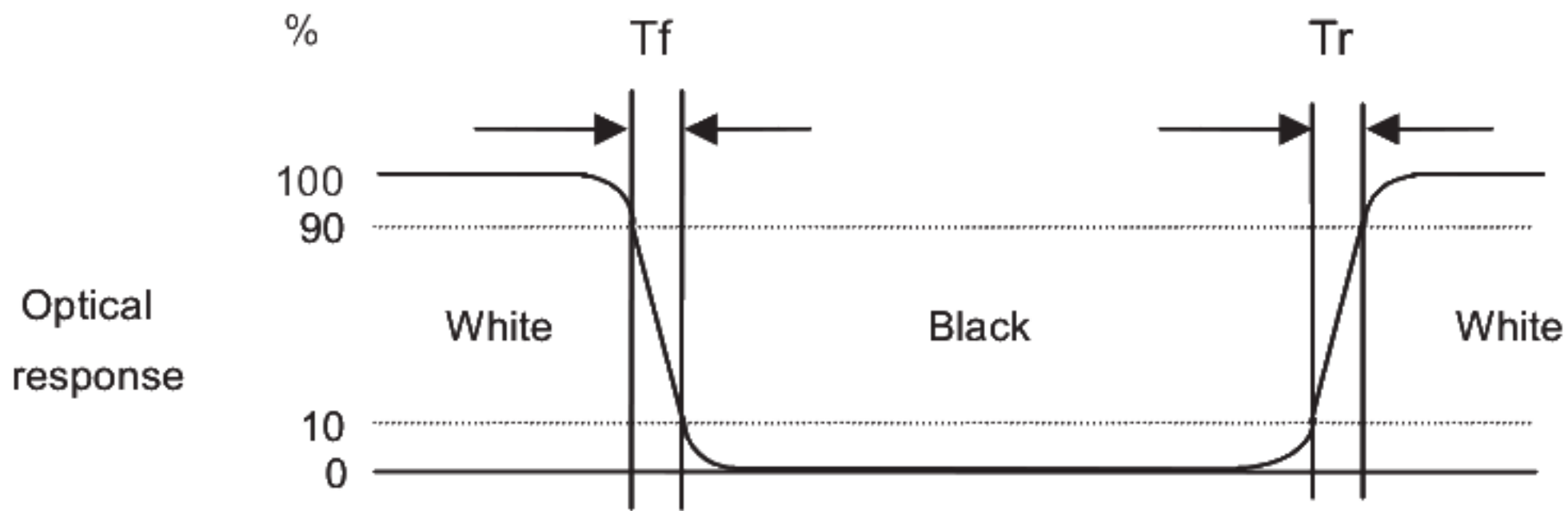

Note 7: Definition of viewing angle

Viewing angle is the measurement of contrast ratio  $\geq 10$ , at the screen center, over a 180° horizontal and 180° vertical range (off-normal viewing angles). The 180° viewing angle range is broken down as below: 90° ( $\theta$ ) horizontal left and right, and 90° ( $\phi$ ) vertical high (up) and low (down). The measurement direction is typically perpendicular to the display surface with the screen rotated to its center to develop the desired measurement viewing angle.

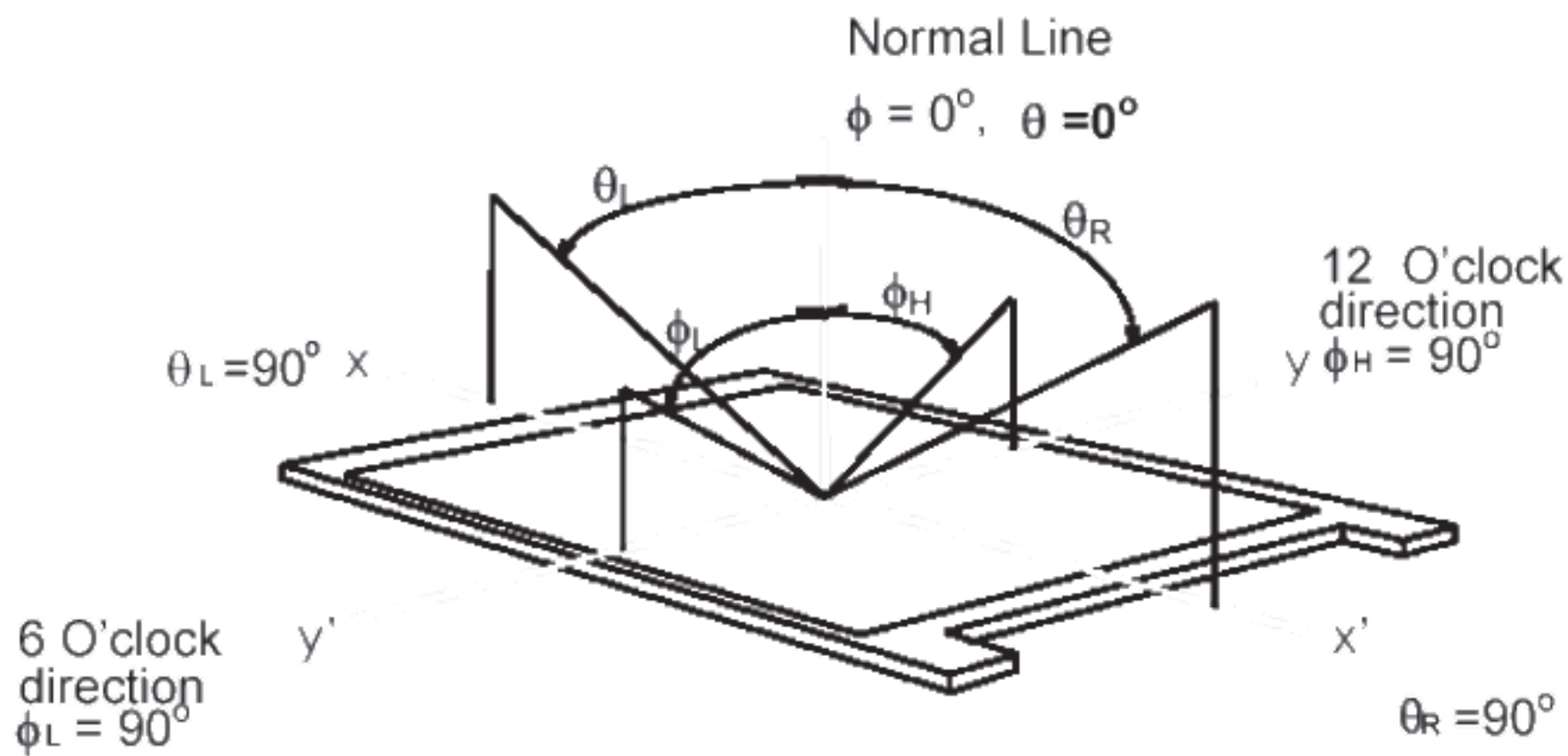



### 3. Functional Block Diagram

The following diagram shows the functional block of the 15 inch color TFT/LCD module:

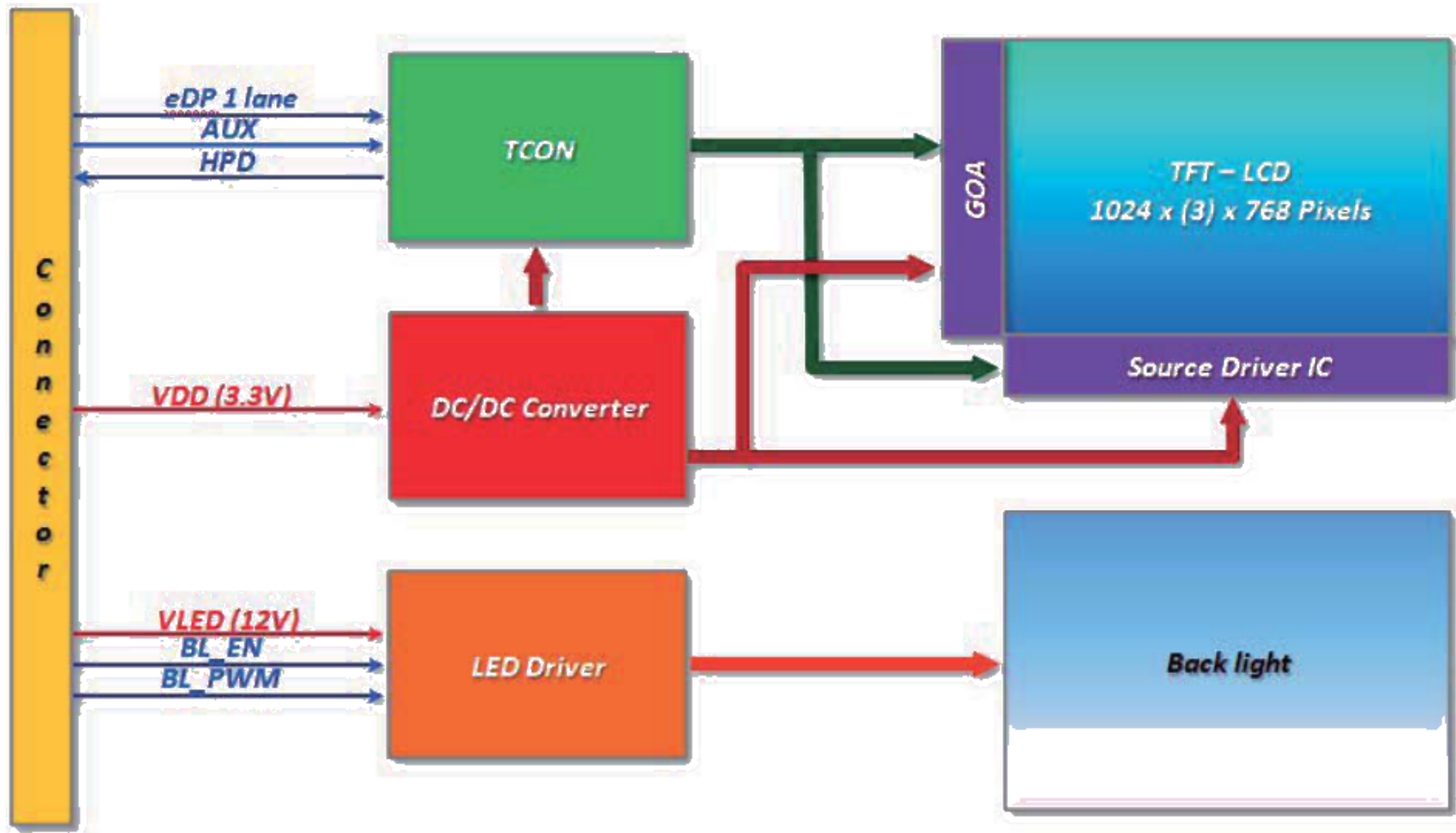

## 4. Absolute Maximum Ratings

### 4.1 Absolute Ratings of TFT LCD Module

| Item                    | Symbol | Min  | Max  | Unit   |
|-------------------------|--------|------|------|--------|
| Logic/LCD Drive Voltage | Vin    | -0.3 | +3.6 | [Volt] |

### 4.2 Absolute Ratings of Environment

| Item                  | Symbol | Min | Max  | Unit  |
|-----------------------|--------|-----|------|-------|
| Operating Temperature | TOP    | 0   | +60* | [°C]  |
| Operation Humidity    | HOP    | 8   | 90   | [%RH] |
| Storage Temperature   | TST    | -20 | +60  | [°C]  |
| Storage Humidity      | HST    | 8   | 90   | [%RH] |

Note: Maximum Wet-Bulb should be 39°C and no condensation.

\* 60 °C is panel surface temperature

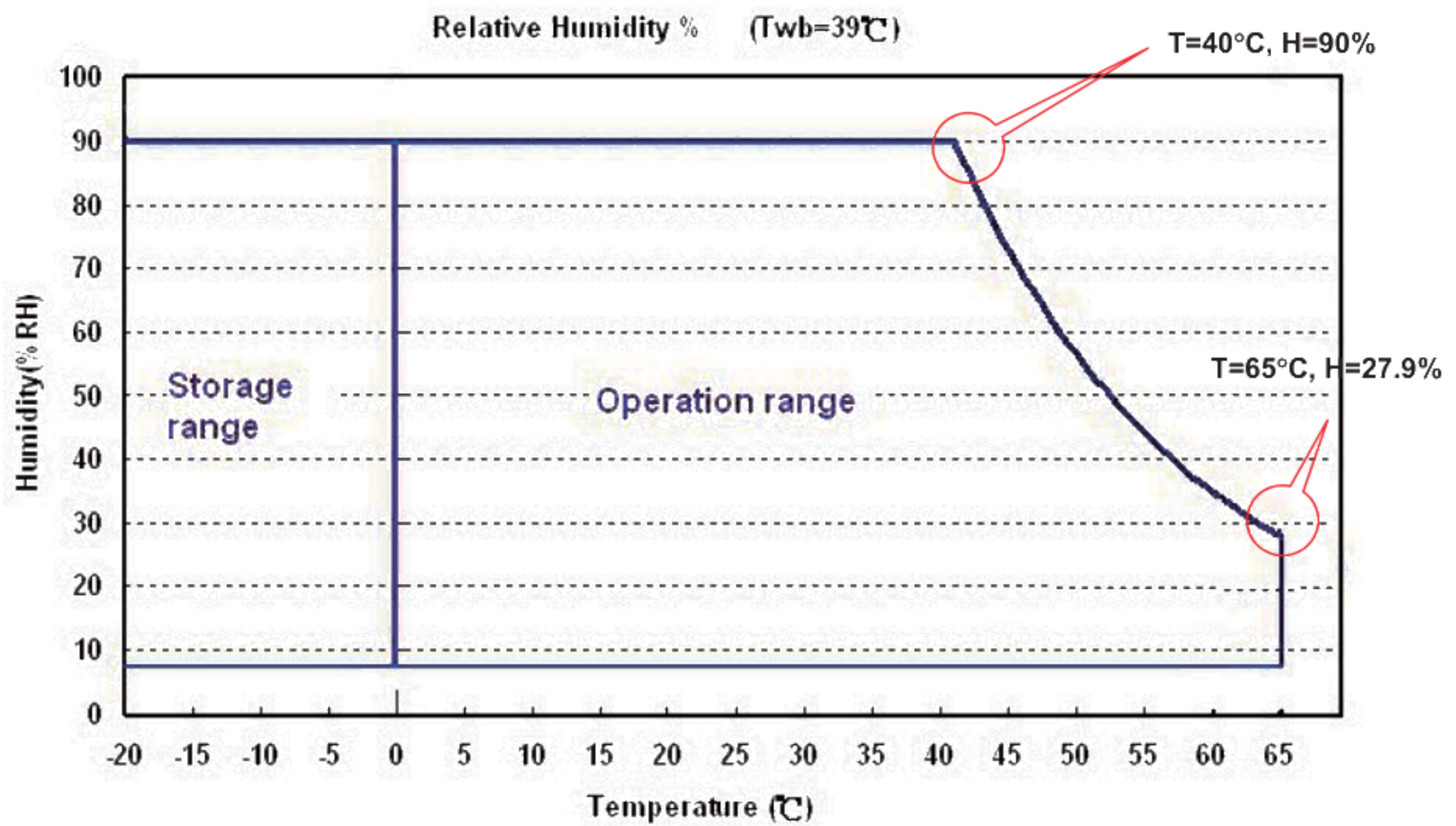

### 5.1 TFT LCD Module

#### 5.1.1 Power Specification

| Symbol | Parameter               | Min | Typ  | Max  | Units  | Remark                               |
|--------|-------------------------|-----|------|------|--------|--------------------------------------|
| VDD    | Logic/LCD Drive Voltage | 3.0 | 3.3  | 3.6  | [Volt] | ± 10%                                |
| IDD    | VDD Current             | -   | 0.78 | 0.94 | [A]    | Black Pattern<br>VDD = 3.3V, at 60Hz |
| Irush  | LCD Inrush Current      |     |      | 3    | [A]    | Note 1                               |
| PDD    | VDD Power               | -   | 2.58 | 3.10 | [Watt] | Black Pattern<br>VDD = 3.3V, at 60Hz |

Note 1: Measurement condition:

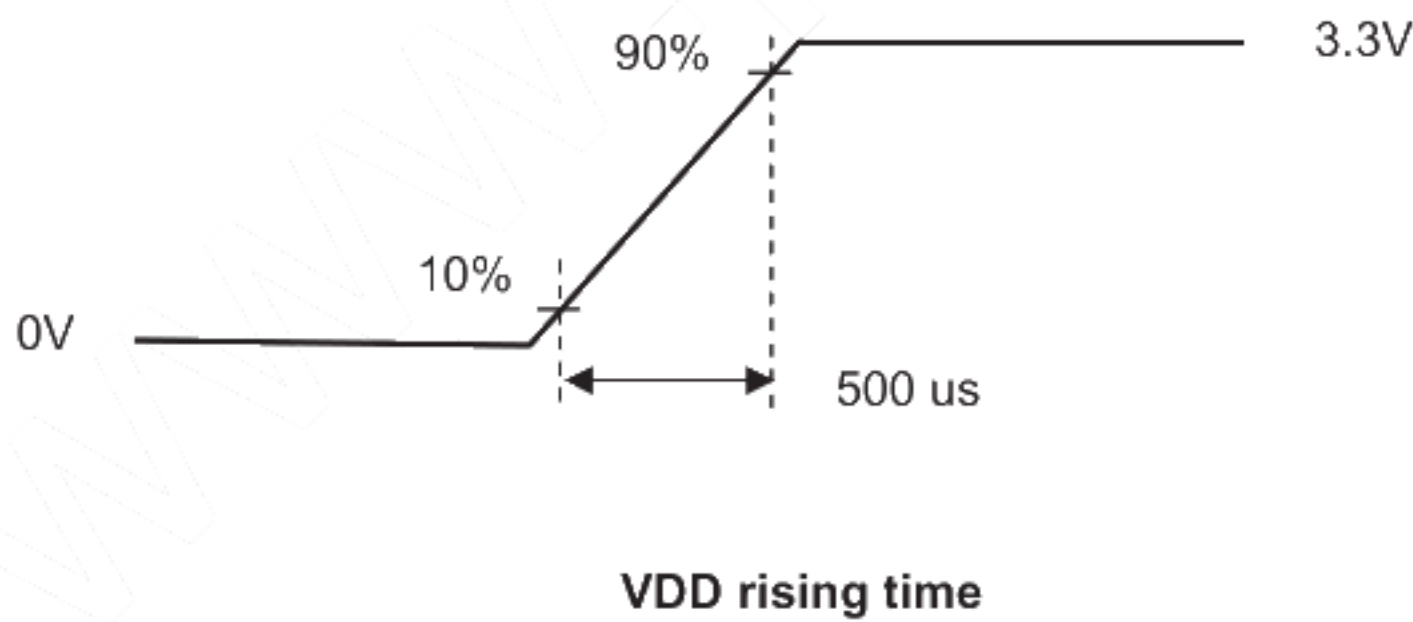
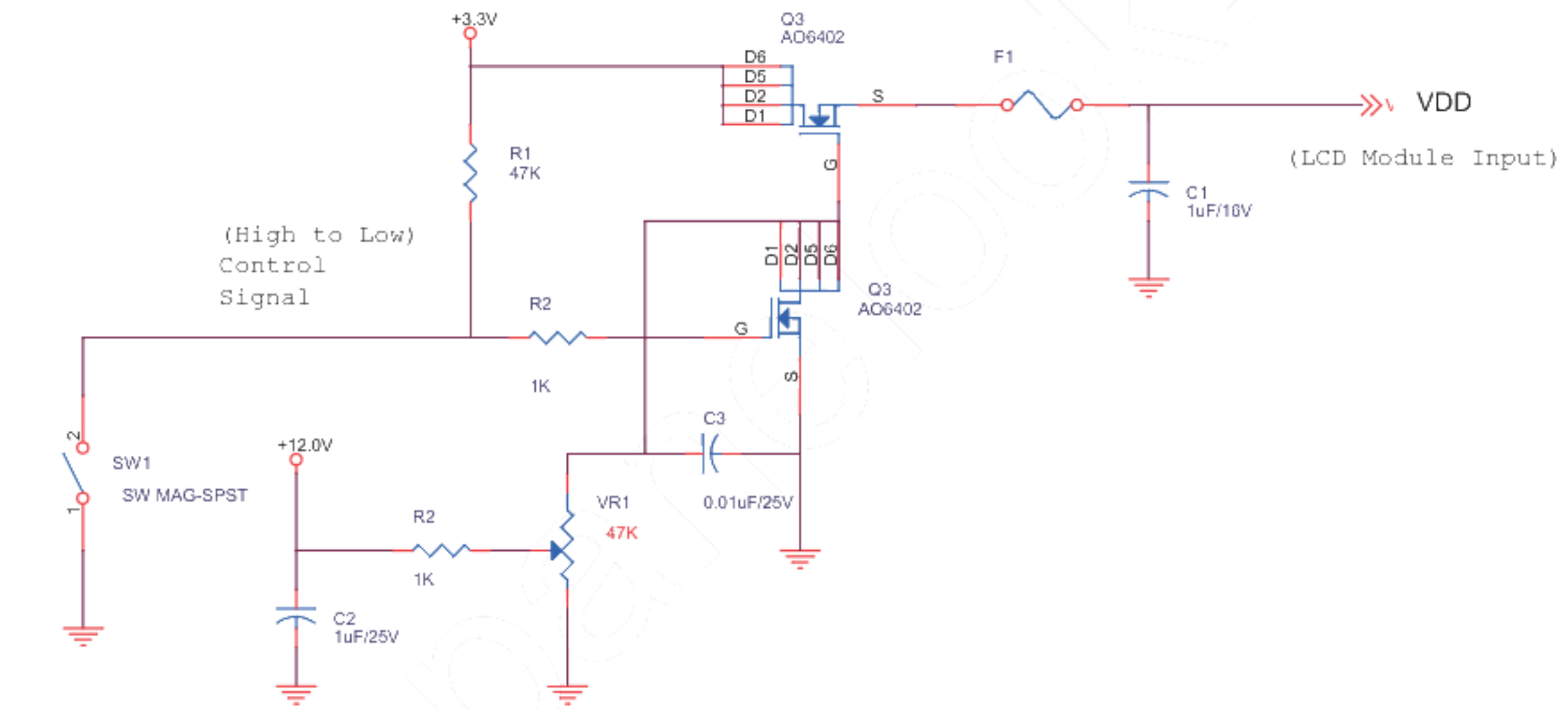

64 Gray pattern

### 5.1.2 Signal Electrical Characteristics

Signal electrical characteristics are as follows:

#### Display Port main link signal:

Differential pair VD+ , VD-  
Which is one Display port  
Main link

VCM of Display port  
Main link

$$V_{diff_{P-P}} = [(VD+) - (VD-)] \times 2$$

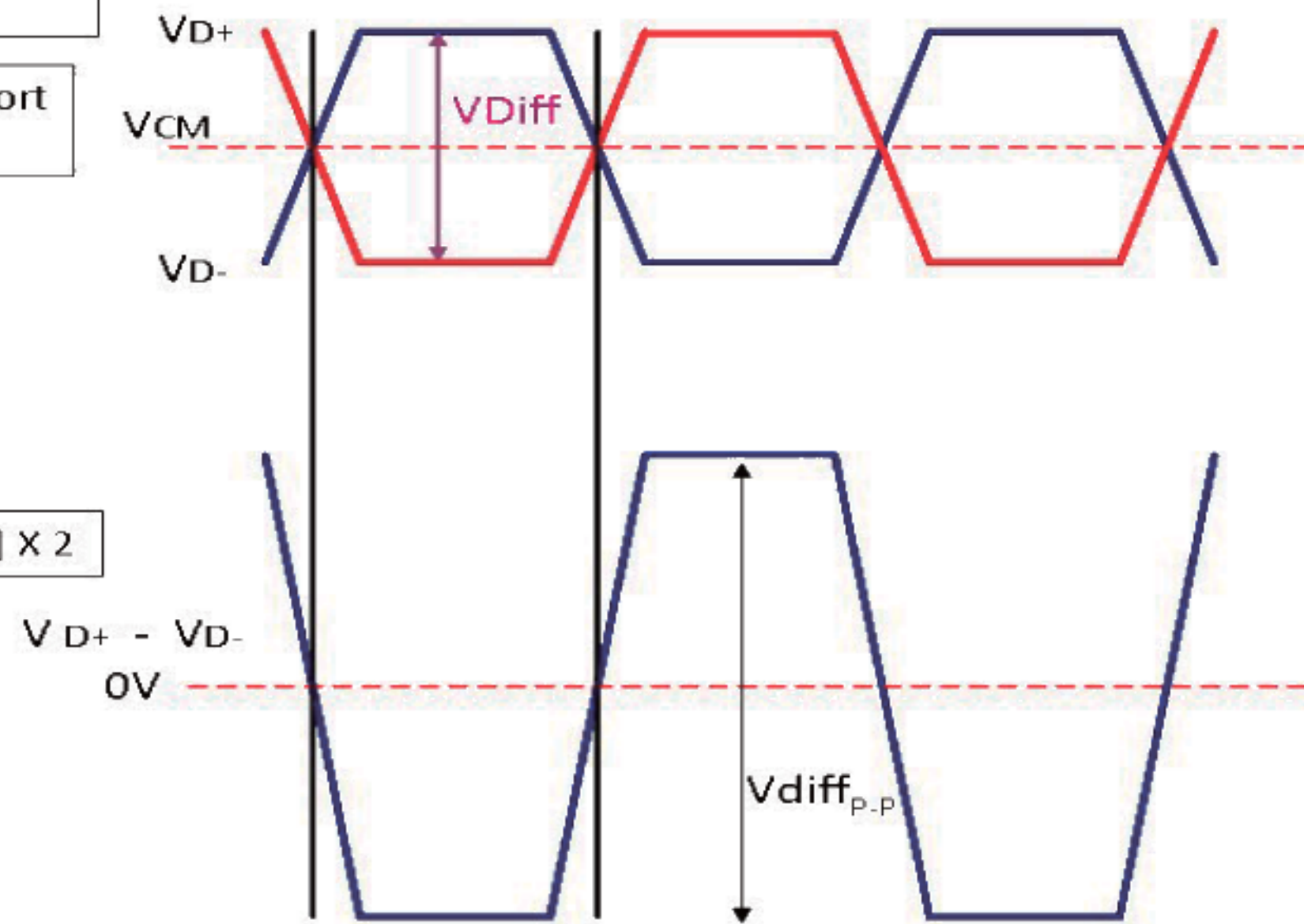

| Display port main link |  |     |     |      |      |
|------------------------|--|-----|-----|------|------|
|                        |  | Min | Typ | Max  | unit |
| VCM                    | RX input DC Common Mode Voltage            |     | 0   |      | V    |
| VDiff <sub>P-P</sub>   | Peak-to-peak Voltage at a receiving Device | 150 |     | 1320 | mV   |

Follow as VESA display port standard V1.1a

#### Display Port AUX\_CH signal:

Differential AUX+ , AUX-  
Which is Display port AUX\_CH

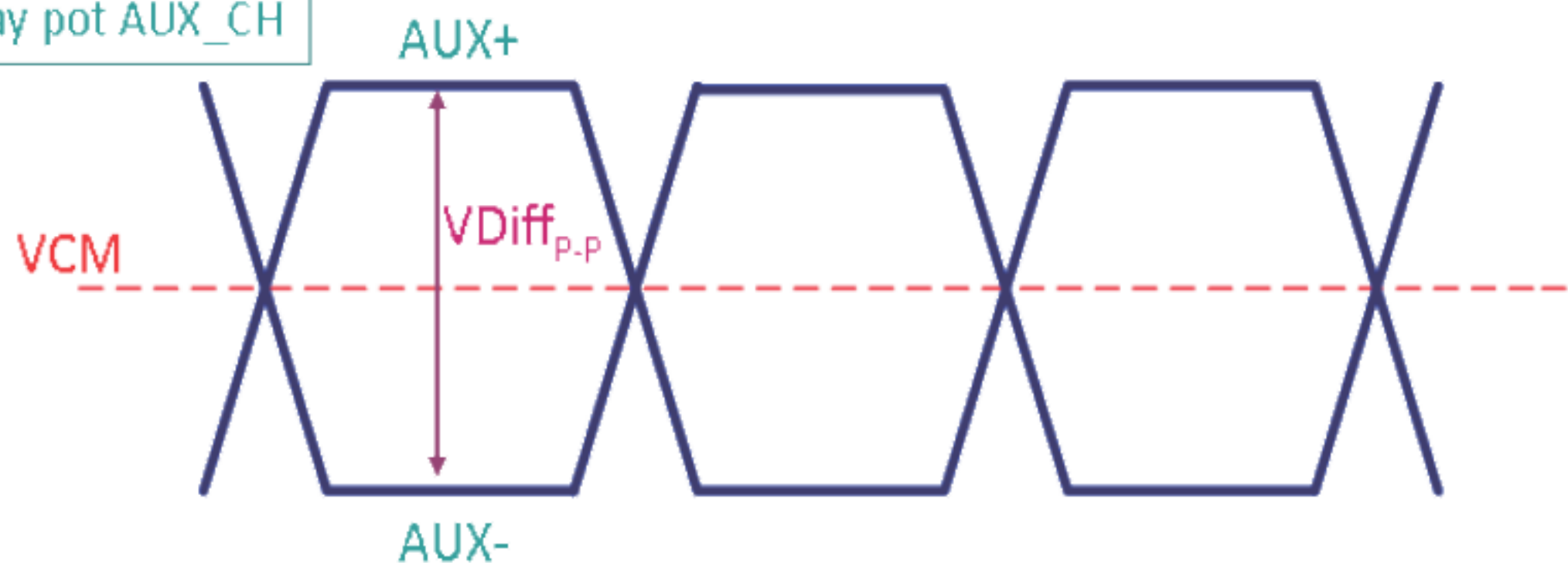

| Display port AUX_CH  |  |     |      |     |      |
|----------------------|--|-----|------|-----|------|
|                      |  | Min | Typ  | Max | unit |
| VCM                  | AUX DC Common Mode Voltage                     |     | 0    |     | V    |
| VDiff <sub>P-P</sub> | AUX Peak-to-peak Voltage at a receiving Device | 0.4 | 0.6- | 0.8 | V    |

Follow as VESA display port standard V1.1a.

**Display Port VHPD signal:**

| Display port VHPD |             |      |     |      |      |
|-------------------|-------------|------|-----|------|------|
|                   |             | Min  | Typ | Max  | unit |
| VHPD              | HPD Voltage | 2.25 | -   | 2.75 | V    |

Follow as VESA display port standard V1.1a.

**5.2 Backlight Unit**

**5.2.1 Parameter guideline for LED**

Following characteristics are measured under stable condition using a LED driving board at 25°C (Room Temperature).

| Symbol         | Parameter             | Min.   | Typ.   | Max. | Unit | Remark                    |
|----------------|-----------------------|--------|--------|------|------|---------------------------|
| Vcc            | Input Voltage         | 10.8   | 12     | 13.2 | Volt |                           |
| Ivcc           | Input Current         | -      | 0.60   | 0.64 | A    | 100% Dimming<br>Vcc = 12V |
| PLED           | Power Consumption     | -      | 7.20   | 7.62 | Watt | 100% Dimming<br>Vcc = 12V |
| Irush          | Inrush Current        |        |        | 2    | A    |                           |
| VLED on/off    | On Control Voltage    | 2.5    | 3.3    | 5.5  | Volt |                           |
|                | Off Control Voltage   |        |        | 0.8  | Volt |                           |
| FPWM           | PWM Dimming Frequency | 200    |        | 10k  | Hz   |                           |
|                | High Voltage          | 2.5    | 3.3    | 5.5  | Volt |                           |
|                | Low Voltage           |        |        | 0.8  | Volt |                           |
|                | Dimming Duty Cycle    | 5      | -      | 100  | %    |                           |
| I <sub>F</sub> | LED Forward Current   |        | 60     |      | mA   | Ta = 25°C                 |
| Operating Life |                       | 50,000 | 70,000 |      | Hrs  | Ta = 25°C                 |

Note 1: Ta means ambient temperature of TFT-LCD module.

Note 2: If G150XTN03.8 module is driven at high ambient temperature & humidity condition. The operating life will be reduced.



Note 3: Definition of life time: LED brightness becomes 50% of its original value. The minimum life time of LED unit is defined at the condition of  $I_{R_{LED}} = 60 \text{ mA}$  and  $25 \pm 2^\circ\text{C}$  (Room temperature).

www.panelook.com

## 6. Signal Characteristic

### 6.1 Pixel Format Image

Following figure shows the relationship between input signal and LCD pixel format.

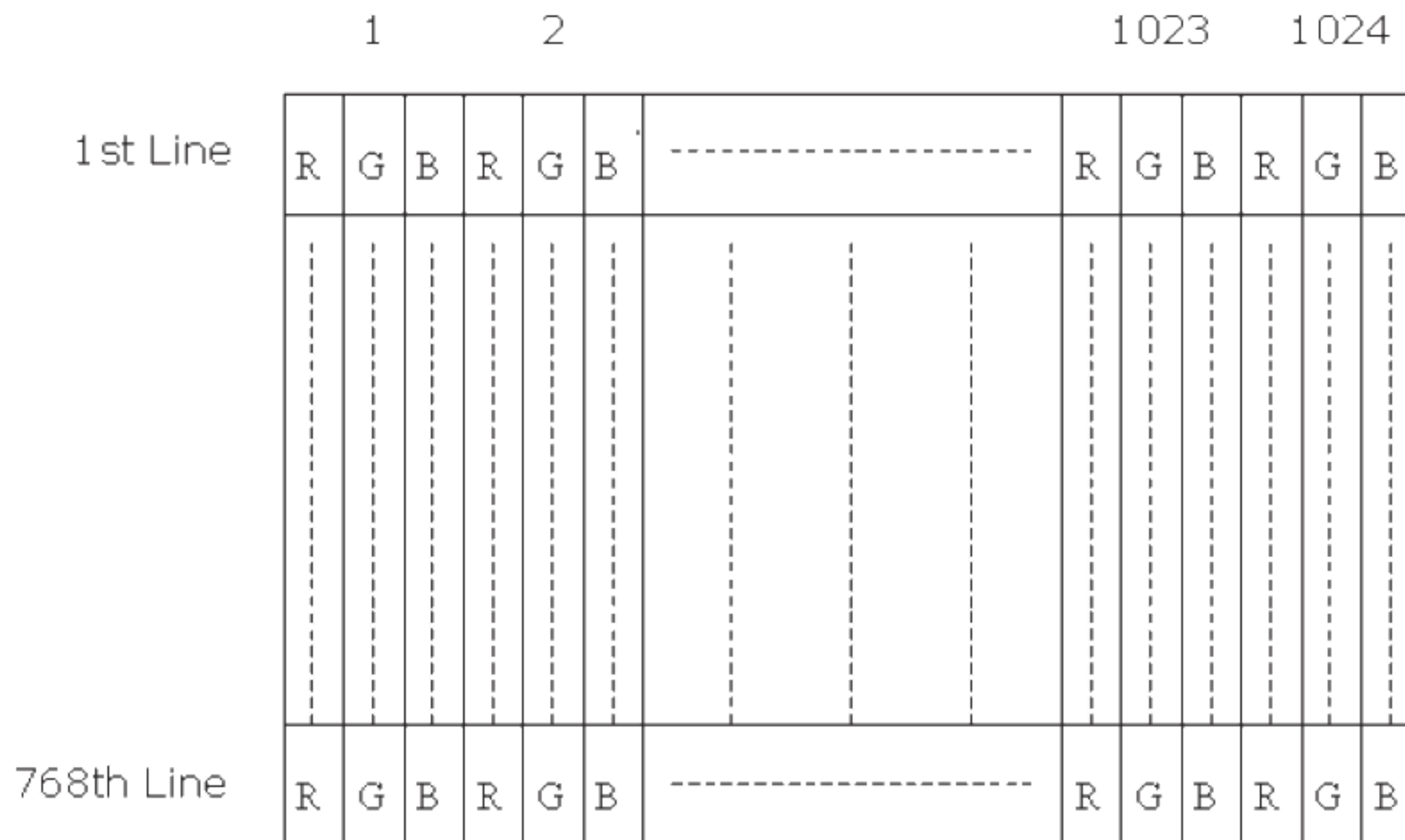

### 6.2 Scanning Direction

The following figures show the image seen from the front view. The arrow indicates the direction of scan.

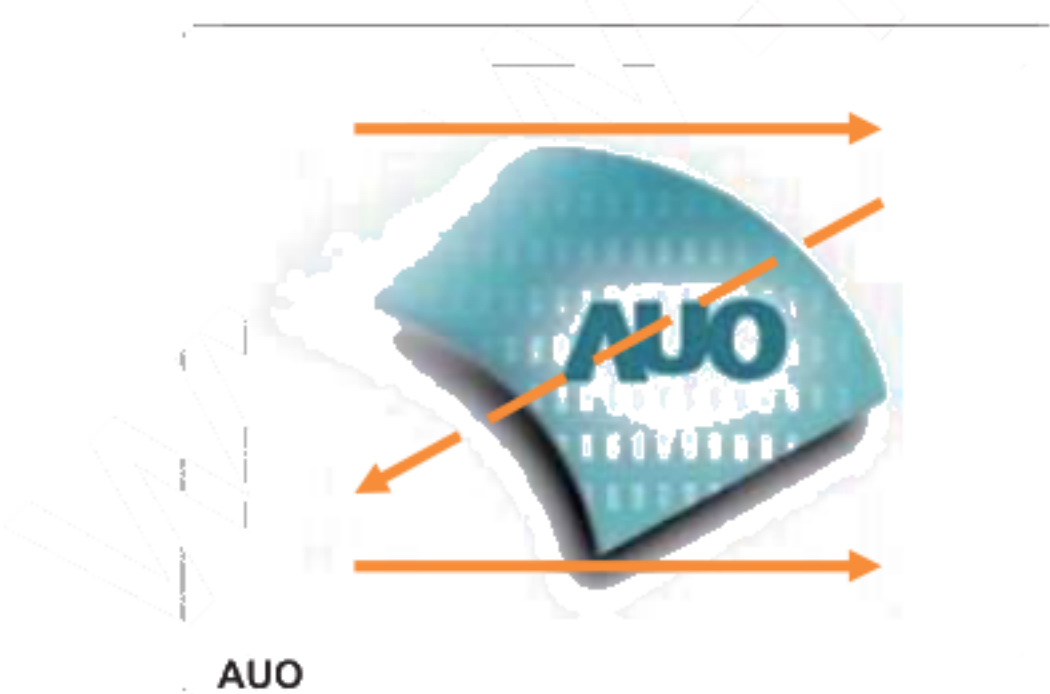

## 6.3 Signal Description

### 6.3.1 Timing Characteristics

Basically, interface timings should match the 1024x768 /60Hz manufacturing guide line timing.

| Parameter          |          | Symbol                | Min. | Typ. | Max. | Unit               |
|--------------------|----------|-----------------------|------|------|------|--------------------|
| Frame Rate         |          | -                     |      | 60   | -    | Hz                 |
| Clock frequency    |          | 1/ T <sub>clock</sub> | 50   | 65   | 81   | MHz                |
| Vertical Section   | Period   | T <sub>V</sub>        | 783  | 806  | 968  | T <sub>Line</sub>  |
|                    | Active   | T <sub>VD</sub>       | 768  |      |      |                    |
|                    | Blanking | T <sub>VB</sub>       | 15   | 38   | 200  |                    |
| Horizontal Section | Period   | T <sub>H</sub>        | 1224 | 1344 | 2024 | T <sub>Clock</sub> |
|                    | Active   | T <sub>HD</sub>       | 1024 |      |      |                    |
|                    | Blanking | T <sub>HB</sub>       | 200  | 320  | 1000 |                    |

Note 1 : The maximum Frame Rate < 81MHz / [(V\_Period)\*(H\_Period)]

Note 2 : Support DE mode only

Note 3 : Typical value refer to VESA STANDARD



## 6.4 Power ON/OFF Sequence

Display Port panel power sequence:

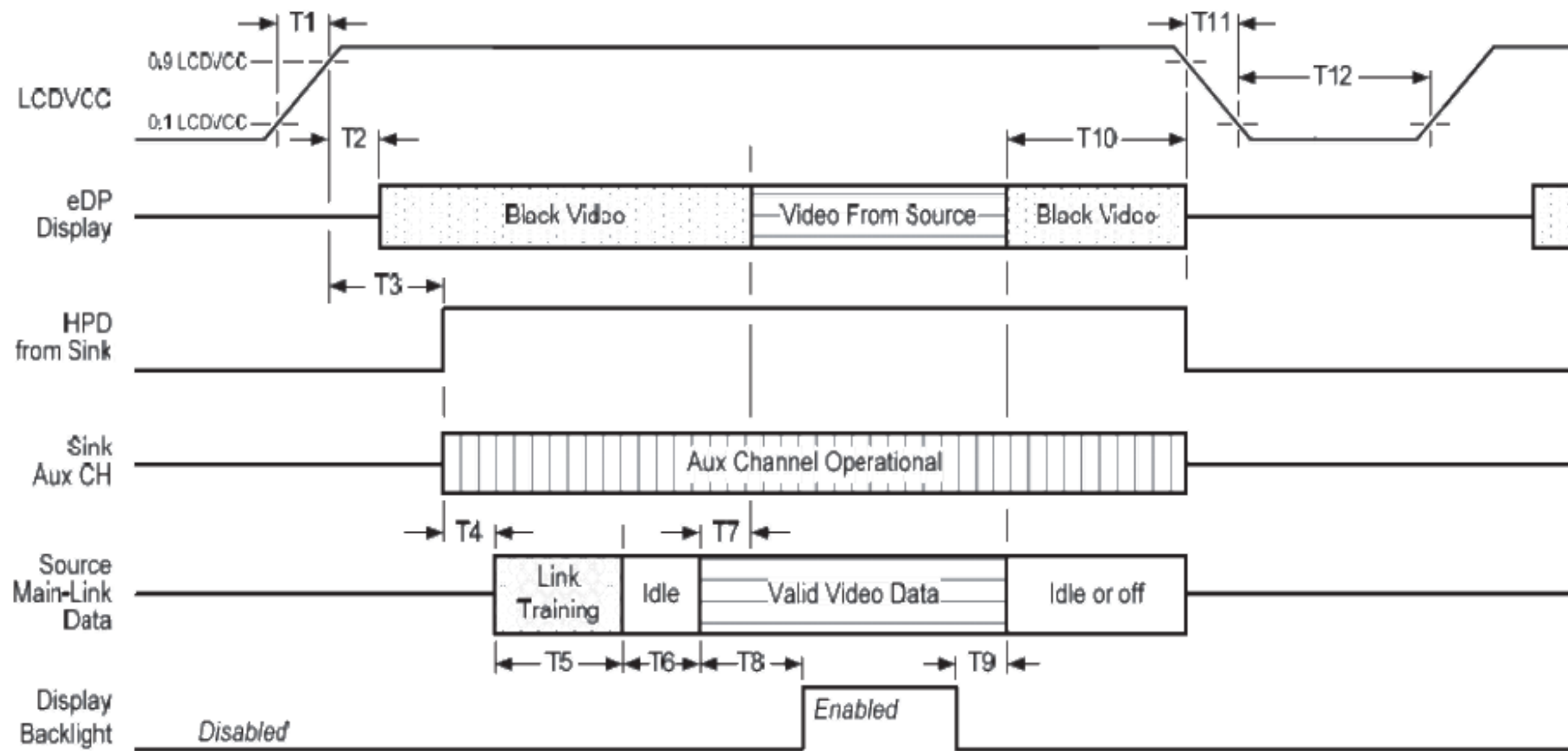

Display port interface power up/down sequence, normal system operation

Display Port AUX\_CH transaction only:

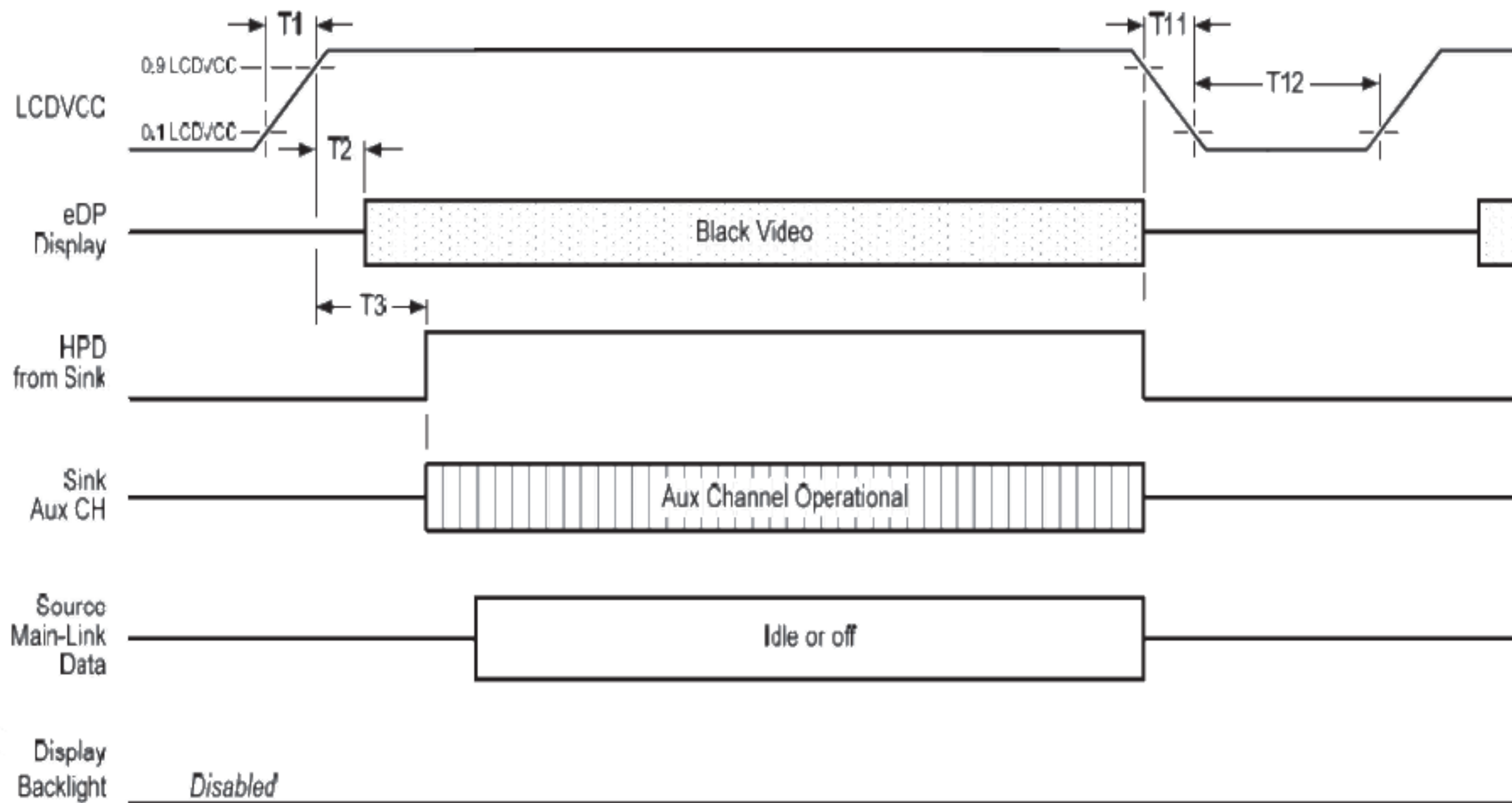

Display port interface power up/down sequence, AUX\_CH transaction only

**Display Port panel power sequence timing parameter:**

| Timing parameter | Description   | Reqd. by | Limits |      |       | Notes  |
|------------------|---|----------|--------|------|-------|--|
|                  |   |          | Min.   | Typ. | Max.  |  |
| T1               | power rail rise time, 10% to 90%                            | source   | 0.5ms  |      | 10ms  |  |
| T2               | delay from LCDVDD to black video generation                 | sink     | 0ms    |      | 200ms | prevents display noise until valid video data is received from the source                  |
| T3               | delay from LCDVDD to HPD high                               | sink     | 0ms    |      | 200ms | sink AUX_CH must be operational upon HPD high.   |
| T4               | delay from HPD high to link training initialization         | source   |        |      |       | allows for source to read link capability and initialize.                                  |
| T5               | link training duration                                      | source   |        |      |       | dependant on source link to read training protocol.  |
| T6               | link idle   | source   |        |      |       | Min accounts for required BS-Idle pattern.<br>Max allows for source frame synchronization. |
| T7               | delay from valid video data from source to video on display | sink     | 0ms    |      | 50ms  | max allows sink validate video data and timing.  |
| T8               | delay from valid video data from source to backlight enable | source   |        |      |       | source must assure display video is stable.  |
| T9               | delay from backlight disable to end of valid video data     | source   |        |      |       | source must assure backlight is no longer illuminated.                                     |
| T10              | delay from end of valid video data from source to power off | source   | 0ms    |      | 500ms |  |
| T11              | power rail fall time, 90% to 10%                            | source   |        |      | 10ms  |  |
| T12              | power off time  | source   | 500ms  |      |       |  |

**Note 1:** The sink must include the ability to generate black video autonomously. The sink must automatically enable black video under the following conditions:

- upon LCDVDD power on (with in T2 max)-when the "Novideostream\_Flag" (VB-ID Bit 3) is received from the source (at the end of T9).
- when no main link data, or invalid video data, is received from the source. Black video must be displayed within 64ms (typ) from the start of either condition. Video data can be deemed invalid based on MSA and timing information, for example.

**Note 2:** The sink may implement the ability to disable the black video function, as described in Note 1, above, for system development and debugging purpose.

**Note 3:** The sink must support AUX\_CH polling by the source immediately following LCDVDD power on without causing damage to the sink device (the source can re-try if the sink is not ready). The sink must be able to respond to an AUX\_CH transaction with the time specified within T3 max.

**Display Port panel B/L power sequence timing parameter:**

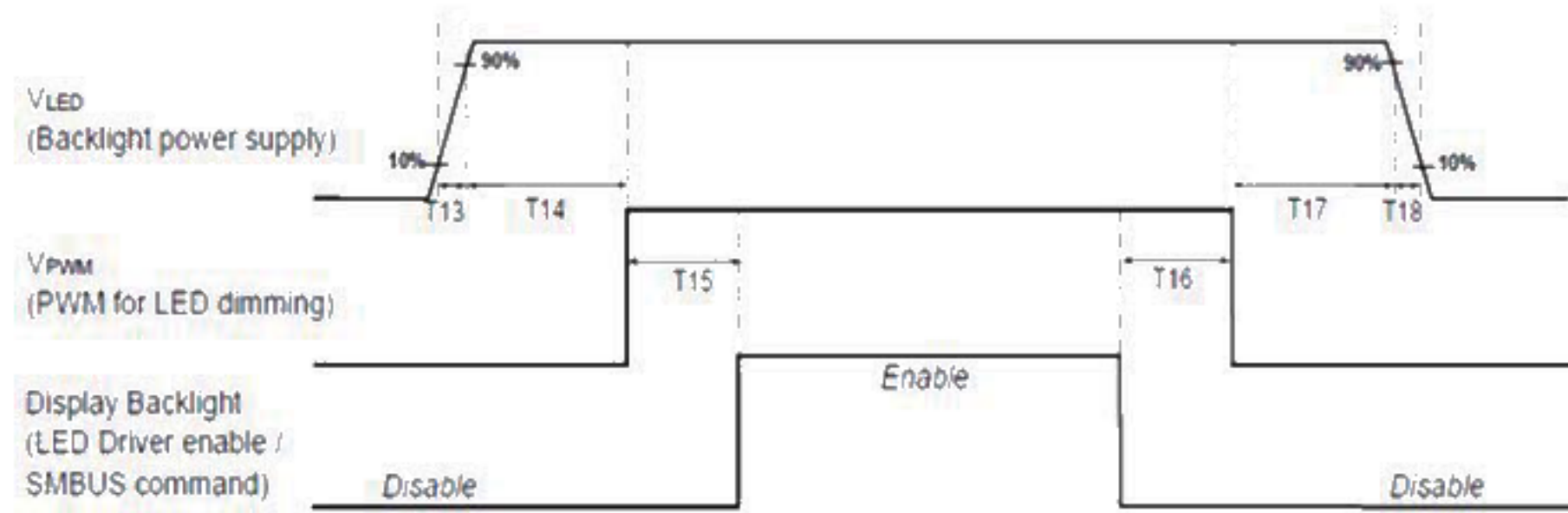

|     | Min (ms) | Max (ms) |
|-----|----------|----------|
| T13 | 0.5      | 10       |
| T14 | 10       | -        |
| T15 | 10       | -        |
| T16 | 10       | -        |
| T17 | 10       | -        |
| T18 | 0.5      | 10       |
| T19 | 1*       | -        |
| T20 | 1*       | -        |

Note : When the adapter is hot plugged, the backlight power supply sequence is shown as below.

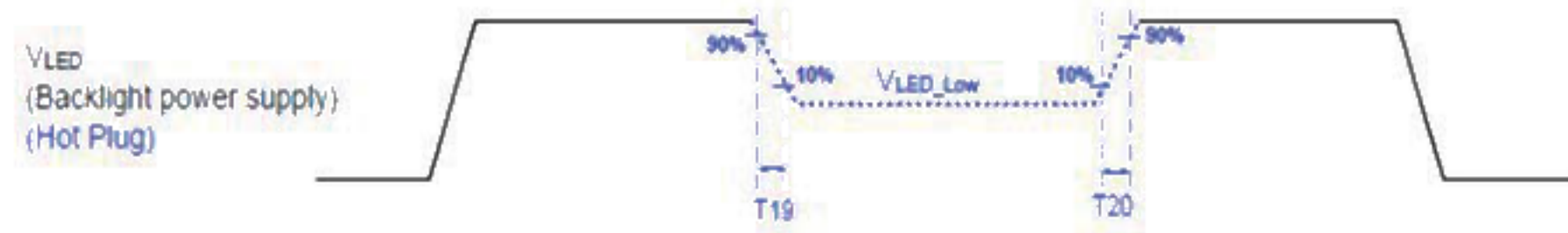

Seamless change:  $T19/T20 = 5 \times T_{PWM}^*$

\* $T_{PWM} = 1/PWM \text{ Frequency}$

www.paneelelook.com

## 7. Integration Interface Requirement

Physical interface is described as for the connector on module.

These connectors are capable of accommodating the following signals and will be following components.

### 7.1 Connector Description

| Connector Name / Designation | For Signal Connector             |
|------------------------------|----------------------------------|
| Manufacturer                 | IPEX or Compatible               |
| Type / Part Number           | IPEX 20455-030E-12 or Compatible |
| Mating Housing/Part Number   | IPEX 20453-030T-11 or Compatible |

www.panelook.com

## 7.2 Pin Assignment (1 Lane)

eDP lane is a differential signal technology for LCD interface and high speed data transfer device.

| PIN NO | Symbol     | Function                      |
|--------|------------|-------------------------------|
| 1      | NC         | No Connect                    |
| 2      | H_GND      | High Speed Ground             |
| 3      | Lane 1_N   | NC                            |
| 4      | Lane 1_P   | NC                            |
| 5      | H_GND      | High Speed Ground             |
| 6      | Lane0_N    | Comp Signal Link Lane 0       |
| 7      | Lane0_P    | True Signal Link Lane 0       |
| 8      | H_GND      | High Speed Ground             |
| 9      | AUX_CH_P   | True Signal Auxiliary Ch.     |
| 10     | AUX_CH_N   | Comp Signal Auxiliary Ch.     |
| 11     | H_GND      | High Speed Ground             |
| 12     | LCD_VCC    | LCD logic and driver power    |
| 13     | LCD_VCC    | LCD logic and driver power    |
| 14     | NC         | No connect                    |
| 15     | LCD GND    | LCD logic and driver ground   |
| 16     | LCD GND    | LCD logic and driver ground   |
| 17     | HPD        | HPD signale pin               |
| 18     | BL_GND     | Backlight_ground              |
| 19     | BL_GND     | Backlight_ground              |
| 20     | BL_GND     | Backlight_ground              |
| 21     | BL_GND     | Backlight_ground              |
| 22     | BL_Enable  | Backlight On / Off            |
| 23     | BL PWM DIM | System PWM signal Input       |
| 24     | NC         | No connect                    |
| 25     | NC         | No connect                    |
| 26     | BL_PWR     | Backlight power (10.8V~13.2V) |
| 27     | BL_PWR     | Backlight power (10.8V~13.2V) |
| 28     | BL_PWR     | Backlight power (10.8V~13.2V) |
| 29     | BL_PWR     | Backlight power (10.8V~13.2V) |
| 30     | NC         | No Connect                    |

### 7.1.1 Connector Illustration

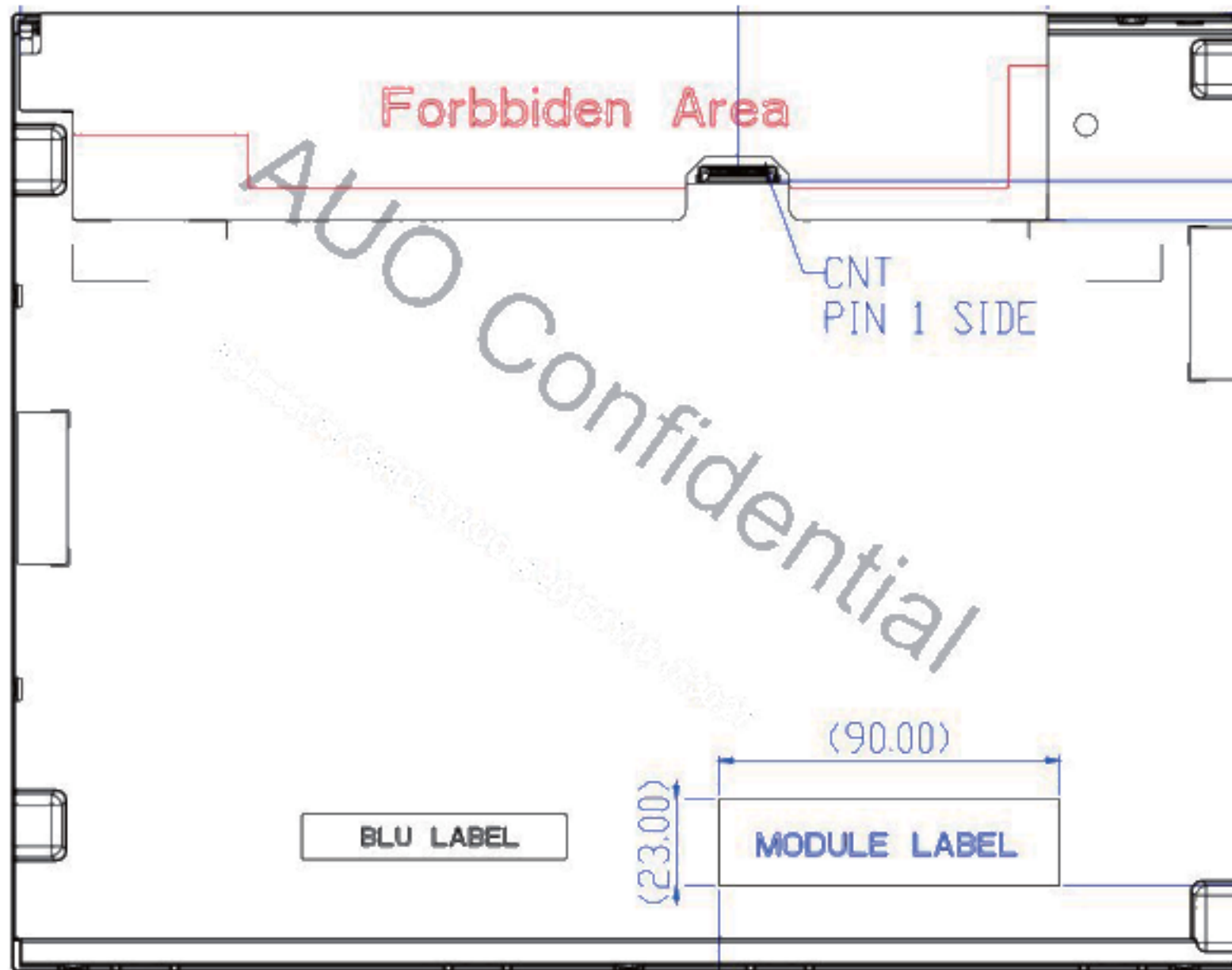

**Note1:** Start from Right side.

**Note2:** Input signals shall be low or High-impedance state when VDD is off. Internal circuit of **eDP inputs** are as following.

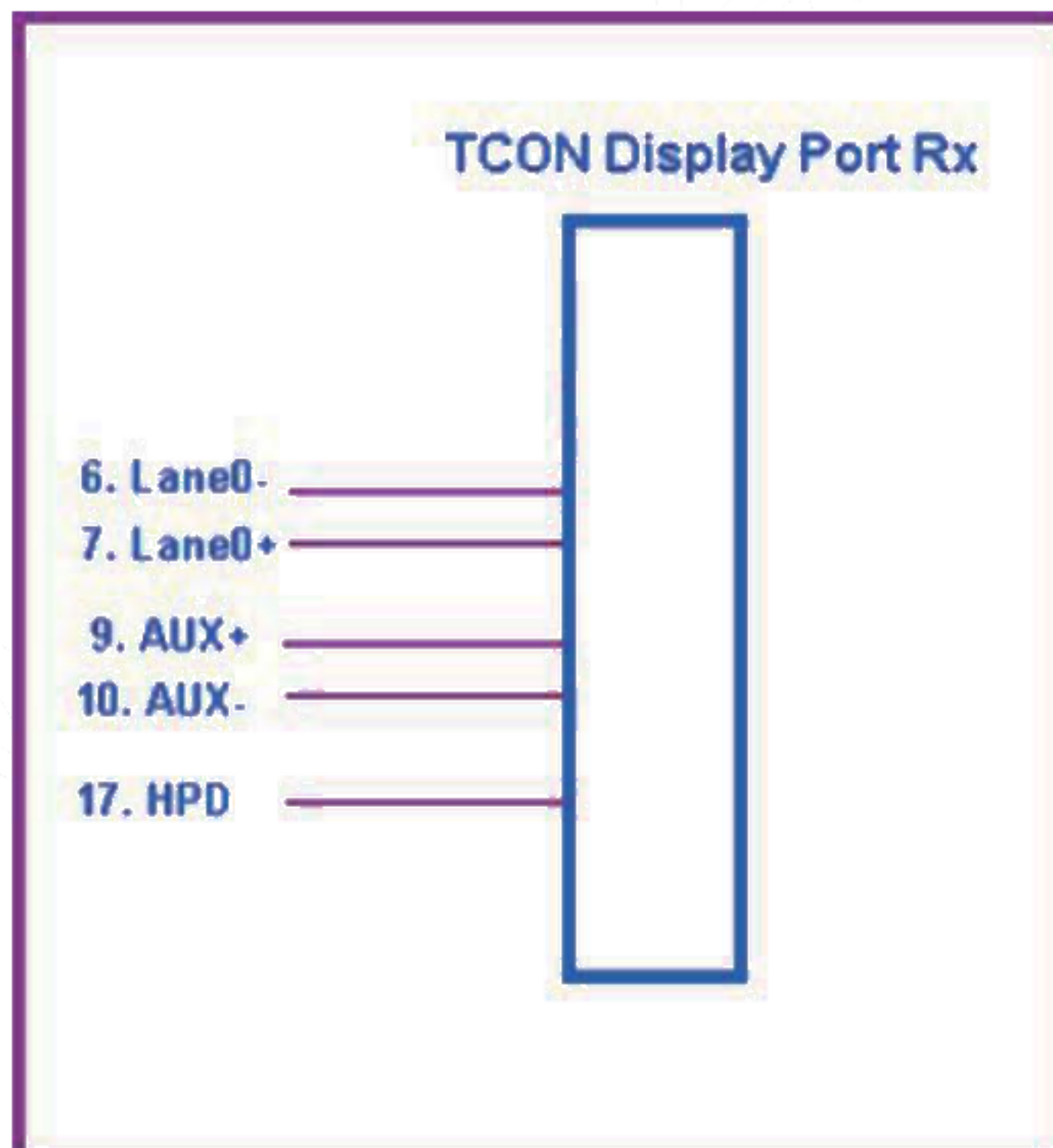

## 8. Reliability Test Criteria

| Items                          | Required Condition  | Note   |
|--------------------------------|---|--------|
| Temperature Humidity Bias      | 50°C/80%,300 hours  |        |
| High Temperature Operation     | 60°C,300 hours  |        |
| Low Temperature Operation      | 0°C,300 hours   |        |
| Hot Storage                    | 60°C,300 hours  |        |
| Cold Storage                   | -20°C,300 hours   |        |
| Thermal Shock Test             | -20°C/30 min ,60°C/30 min ,100cycles  |        |
| Shock Test (Non-Operating)     | 50G,20ms,Half-sine wave,( ±X, ±Y, ±Z)   |        |
| Vibration Test (Non-Operating) | 1.5G, (10~200~10Hz, P-P)<br>30 mins/axis (X, Y, Z)  |        |
| On/off test                    | On/10 sec, Off/10 sec, 30,000 cycles  |        |
| ESD                            | Contact Discharge: ± 8KV, 150pF(330Ω ) 1sec, 8 points, 25 times/ point<br>Air Discharge: ± 15KV, 150pF(330Ω ) 1sec, 8 points, 25 times/ point | Note 1 |

Note1: According to EN61000-4-2, ESD class B: Some performance degradation allowed. No data lost  
Self-recoverable. No hardware failures.

Note 2:

- Water condensation is not allowed for each test items.
- Each test is done by new TFT-LCD module. Don't use the same TFT-LCD module repeatedly for reliability test.
- The reliability test is performed only to examine the TFT-LCD module capability.
- To inspect TFT-LCD module after reliability test, please store it at room temperature and room humidity for 24 hours at least in advance.
- No function failure occurs. Mura shall be ignored after high temperature reliability test.

## 9. Mechanical Characteristics

### 9.1 LCM Outline Dimension (Front View)

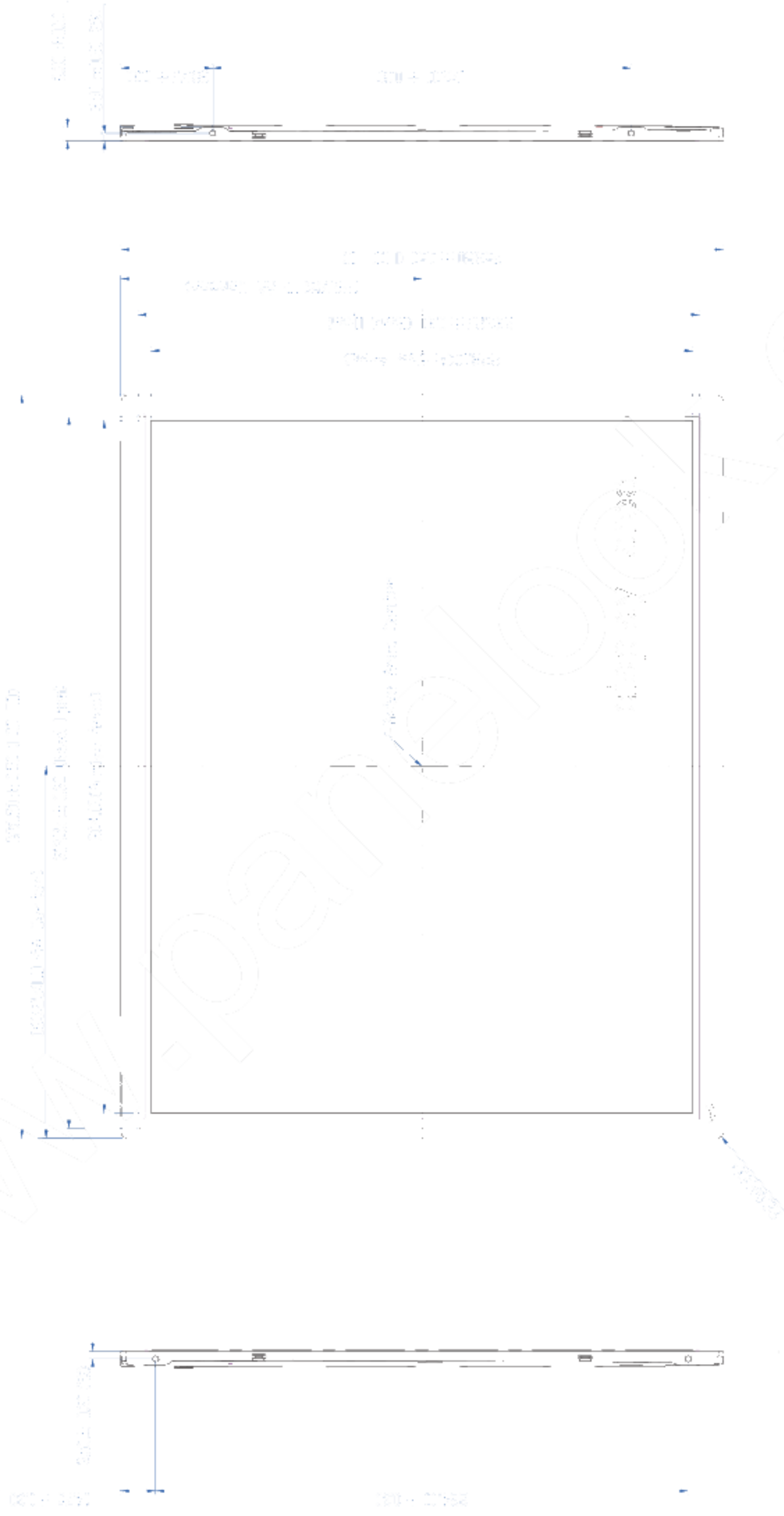

Notes:  
 1. Dimensions are in millimeters.  
 2. Surface finish is as per drawing.

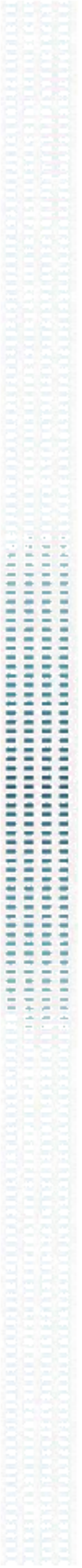





G150XTN03.8

## 9.2 LCM Outline Dimension (Rear View)

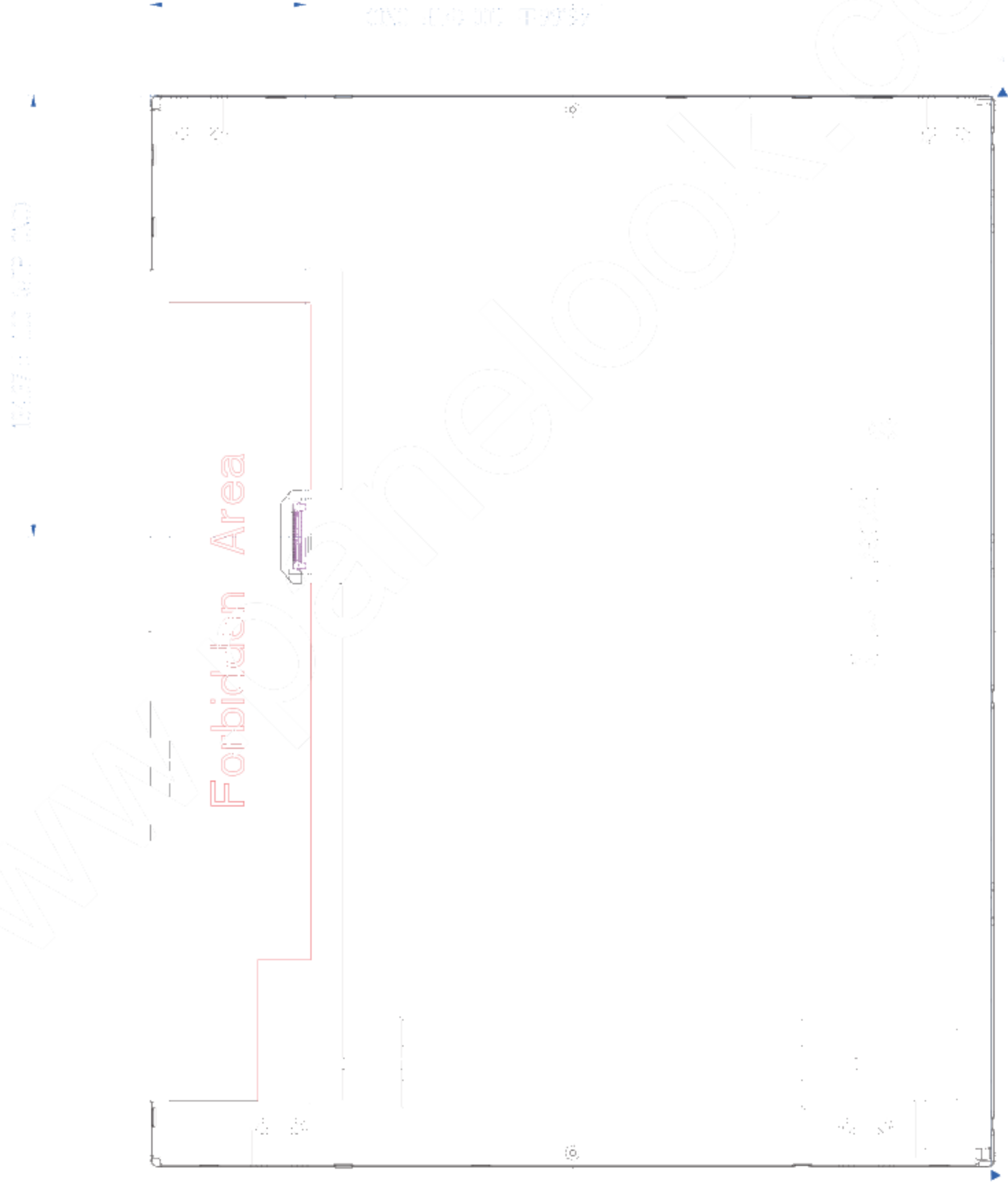

## 10. Label and Packaging

### 10.1 Shipping Label (on the rear side of TFT-LCD display)

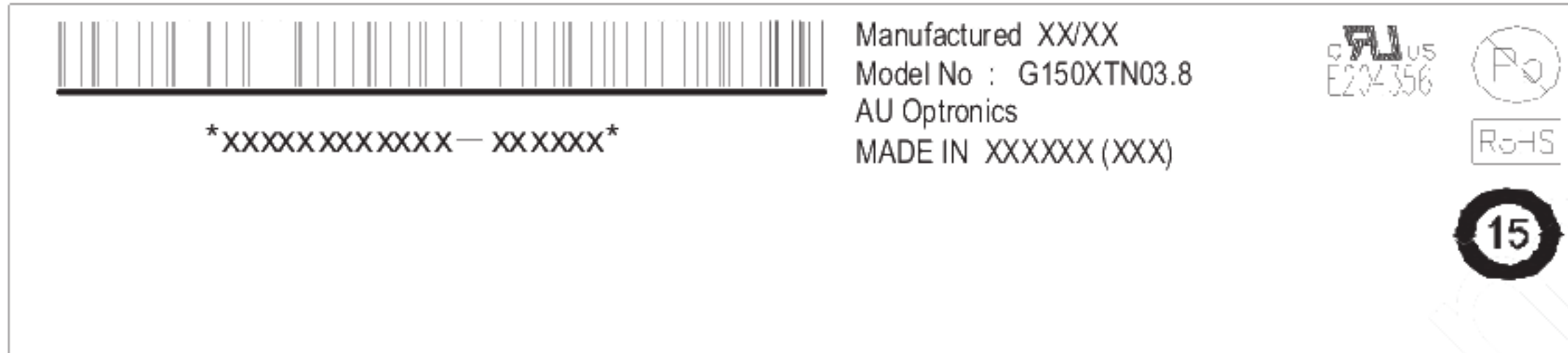

### 10.2 Carton Package

- Max capacity : 20 TFT-LCD module per carton
- Max weight: 17 kg per carton
- Outside dimension of carton: 413mm(L)\* 366mm(W)\*359mm(H)
- Pallet size : 1140 mm \* 830 mm \* 135mm

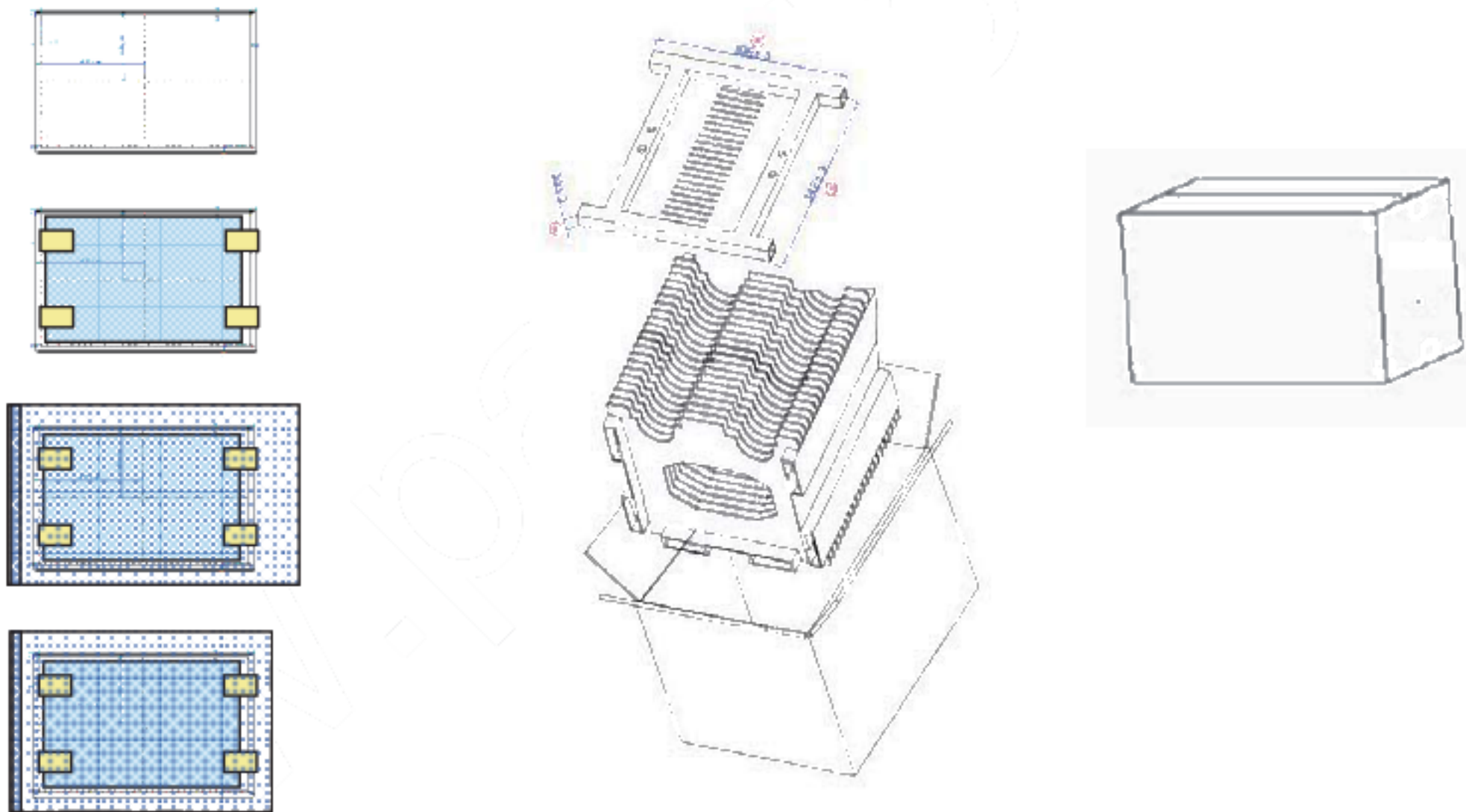

### 10.3 Palletizing

Box stacked

Module by air : (2 \*3) \*4 layers , one pallet put 24 boxes , total 480pcs module

Module by sea : (2 \*3) \*3 layers+ (2 \*3) \*2 layers , two pallet put 30 boxes , total 600pcs module

Module by sea\_HQ : (2 \*3) \*3 layers+ (2 \*3) \*3 layers , two pallet put 36 boxes , total 720pcs module

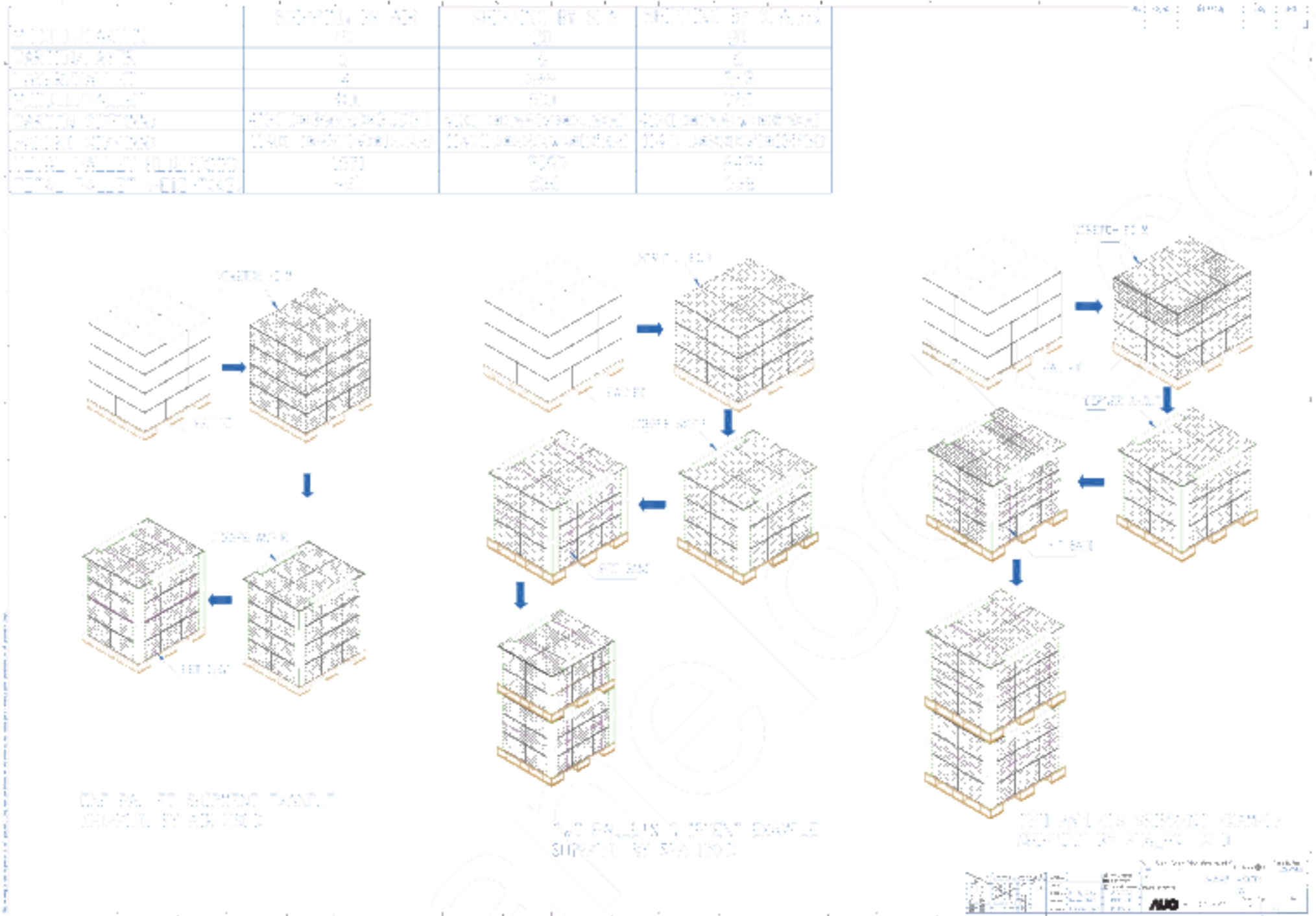

## 11 Safety

### 11.1 Sharp Edge Requirements

There will be no sharp edges or comers on the display assembly that could cause injury.

### 11.2 Materials

#### 11.2.1 Toxicity

There will be no carcinogenic materials used anywhere in the display module. If toxic materials are used, they will be reviewed and approved by the responsible AUO toxicologist.

#### 11.2.2 Flammability

All components including electrical components that do not meet the flammability grade UL94-V1 in the module will complete the flammability rating exception approval process.

The printed circuit board will be made from material rated 94-V1 or better. The actual UL flammability rating will be printed on the printed circuit board.

### 11.3 Capacitors

If any polarized capacitors are used in the display assembly, provisions will be made to keep them from being inserted backwards.

### 11.4 National Test Lab Requirement

The display module will satisfy all requirements for compliance to:

**UL 60950-1, Second Edition**

U.S.A. Information Technology Equipment