

**Doc. Number :**

- Tentative Specification
- Preliminary Specification
- Approval Specification

**MODEL NO.: G156BGE**  
**SUFFIX: L01**

<b>Customer:</b>	
<b>APPROVED BY</b>	<b>SIGNATURE</b>
<b>Name / Title</b> _____	_____
Note	
<p>_____</p> <p>Please return 1 copy for your confirmation with your signature and comments.</p>	

Approved By	Checked By	Prepared By
yuhsiang.chang (張喻翔/514-10922)	yuhsiang.chang (張喻翔/514-10922)	archers.huang (黃清鴻/514-10920)
2013-12-10 19:01:28 CST	2013-12-10 19:01:28 CST	2013-12-10 18:45:17 CST

## CONTENTS

<b>1. GENERAL DESCRIPTION .....</b>	<b>4</b>
1.1 OVERVIEW .....	4
1.2 GENERAL SPECIFICATIONS .....	4
<b>2. MECHANICAL SPECIFICATIONS .....</b>	<b>4</b>
<b>3. ABSOLUTE MAXIMUM RATINGS .....</b>	<b>5</b>
3.1 ABSOLUTE RATINGS OF ENVIRONMENT .....	5
3.2 ELECTRICAL ABSOLUTE RATINGS .....	5
3.2.1 TFT LCD MODULE .....	5
3.2.2 BACKLIGHT CONVERTER.....	6
<b>4. ELECTRICAL SPECIFICATIONS.....</b>	<b>6</b>
4.1 FUNCTION BLOCK DIAGRAM .....	6
4.2. INTERFACE CONNECTIONS .....	7
4.3 ELECTRICAL CHARACTERISTICS .....	8
4.3.1 LCD ELETRONICS SPECIFICATION .....	8
4.3.2 Vcc Power Dip Condition.....	10
4.3.3 BACKLIGHT UNIT.....	10
4.3.4 BACKLIGHT PIN ASSIGNMENT.....	11
4.4 LVDS INPUT SIGNAL SPECIFICATIONS .....	11
4.4.1 LVDS DATA MAPPING TABLE .....	11
4.4.2 COLOR DATA INPUT ASSIGNMENT.....	12
4.5 DISPLAY TIMING SPECIFICATIONS .....	13
4.6 POWER ON/OFF SEQUENCE.....	15
<b>5. OPTICAL CHARACTERISTICS .....</b>	<b>16</b>
5.1 TEST CONDITIONS .....	16
5.2 OPTICAL SPECIFICATIONS.....	16
<b>6. RELIABILITY TEST ITEM .....</b>	<b>19</b>
<b>7. PACKING.....</b>	<b>20</b>
<b>8. MODULE LABEL.....</b>	<b>21</b>
<b>9. PRECAUTIONS .....</b>	<b>23</b>
9.1 ASSEMBLY AND HANDLING PRECAUTIONS .....	23
9.2 STORAGE PRECAUTIONS .....	23
9.3 OPERATION PRECAUTIONS .....	23
9.4 SAFETY PRECAUTIONS .....	24
9.5 SAFETY STANDARDS .....	24
9.6 OTHER.....	24

## REVISION HISTORY

Version	Date	Page	Description
1.0	Dec.9, 2013	All	Spec Ver. 1.0 was first issued.



## 1. GENERAL DESCRIPTION

### 1.1 OVERVIEW

G156BGE-L01 is a 15.6" TFT Liquid Crystal Display module with WLED Backlight unit and 30 pins 1ch-LVDS interface. This module supports 1366 x 768 WXGA mode and can display up to 16.7M colors. The converter module for Backlight is built in.

### 1.2 GENERAL SPECIFICATIONS

Item	Specification	Unit	Note
Screen Size	15.6" real diagonal		
Driver Element	a-si TFT active matrix	-	-
Pixel Number	1366 x R.G.B. x 768	pixel	-
Pixel Pitch	0.252 (H) x 0.252 (V)	mm	-
Pixel Arrangement	RGB vertical stripe	-	-
Display Colors	262K/16.7M	color	-
Transmissive Mode	Normally white	-	-
Surface Treatment	AG type, 3H hard coating,	-	-
Luminance, White	300	Cd/m2	
Color Gamut	65 % of NTSC(Typ.)	-	-
Power Consumption	(10.95)	W	

## 2. MECHANICAL SPECIFICATIONS

Item		Min.	Typ.	Max.	Unit	Note
Module Size	Horizontal (H)	363.3	363.8	364.3	mm	
	Vertical (V)	215.42	215.92	216.42	mm	
	Thickness (T)	16.35	16.85	17.35	mm	
Bezel Area	Horizontal	347.03	347.53	347.03	mm	
	Vertical	196.34	196.84	197.34	mm	
Active Area	Horizontal	-	344.232	-	mm	
	Vertical	-	193.536	-	mm	
Weight		-	1190	1250	g	

## 3. ABSOLUTE MAXIMUM RATINGS

### 3.1 ABSOLUTE RATINGS OF ENVIRONMENT

Item	Symbol	Value		Unit	Note
		Min.	Max.		
Storage Temperature	TST	-20	60	°C	(1)
Operating Ambient Temperature	TOP	0	(60)	°C	(1), (2)

Note (1)

(a) 90 %RH Max. ( $T_a < 40\text{ °C}$ ).

(b) Wet-bulb temperature should be  $39\text{ °C}$  Max. ( $T_a < 40\text{ °C}$ ).

(c) No condensation.

Note (2) The temperature of panel surface should be  $0\text{ °C}$  min. and  $60\text{ °C}$  max.

### 3.2 ELECTRICAL ABSOLUTE RATINGS

#### 3.2.1 TFT LCD MODULE

Item	Symbol	Value		Unit	Note
		Min.	Max.		
Power Supply Voltage	VCCS	-0.3	6.0	V	(1)
Logic Input Voltage	VIN	-0.3	6	V	

### 3.2.2 BACKLIGHT CONVERTER

Item	Symbol	Value			Unit	Note
		Min.	Typ	Max.		
Converter Voltage	LED_V <sub>in</sub>	0	12.0	18.0	V	(1), (2) Duty=100%
Enable Voltage	LED_EN	0	3.3 / 5	7	V	
Backlight Adjust	LED_PWM	0	3.3 / 5	7	V	(1), (2) Pulse Width ≤ 10msec. and Duty ≤ 10%

Note (1) Permanent damage to the device may occur if maximum values are exceeded. Function operation should be restricted to the conditions described under Normal Operating Conditions.

Note (2) Specified values are for input pin of LED light bar at Ta=25±2 °C (Refer to 4.3.3 and 4.3.4 for further information).

## 4. ELECTRICAL SPECIFICATIONS

### 4.1 FUNCTION BLOCK DIAGRAM

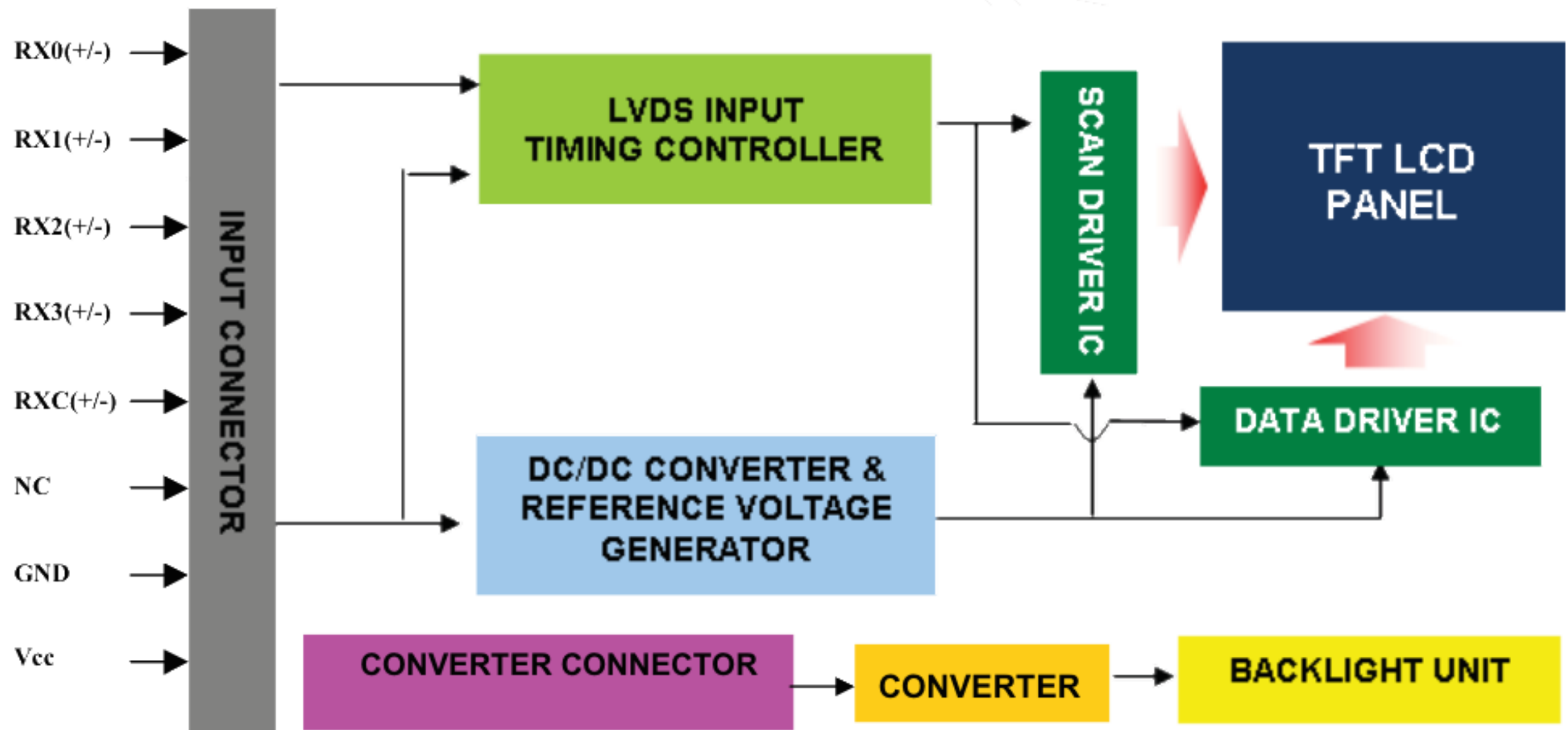



## 4.2. INTERFACE CONNECTIONS

### PIN ASSIGNMENT

Pin	Name	Description
1	GND	Ground
2	NC	Not connection, this pin should be open.
3	NC	Not connection, this pin should be open.
4	GND	Ground
5	RX0-	Negative LVDS differential data input. Channel 0
6	RX0+	Positive LVDS differential data input. Channel 0
7	GND	Ground
8	RX1-	Negative LVDS differential data input. Channel 1
9	RX1+	Positive LVDS differential data input. Channel 1
10	GND	Ground
11	RX2-	Negative LVDS differential data input. Channel 2
12	RX2+	Positive LVDS differential data input. Channel 2
13	GND	Ground
14	RXCLK-	Negative LVDS differential clock input.
15	RXCLK+	Positive LVDS differential clock input.
16	GND	Ground
17	RX3-	Negative LVDS differential data input. Channel 3
18	RX3+	Positive LVDS differential data input. Channel 3
19	GND	Ground
20	NC	Not connection, this pin should be open.
21	NC	Not connection, this pin should be open.
22	NC	Not connection, this pin should be open.
23	GND	Ground
24	GND	Ground
25	GND	Ground
26	Vcc	+5V power supply
27	Vcc	+5V power supply
28	Vcc	+5V power supply
29	Vcc	+5V power supply
30	Vcc	+5V power supply

Note (1) Connector Part No.:

187114-30091, P2

Note (2) The first pixel is odd.

Note (3) Input signal of even and odd clock should be the same timing.

## 4.3 ELECTRICAL CHARACTERISTICS

### 4.3.1 LCD ELETRONICS SPECIFICATION

Parameter	Symbol	Value			Unit	Note
		Min.	Typ.	Max.		
Power Supply Voltage	V <sub>CC</sub>	(4.5)	(5)	(5.5)	V	-
Ripple Voltage	V <sub>RP</sub>	-	-	(150)	mV	-
Rush Current	I <sub>RUSH</sub>	-	-	(3)	A	(2)
Power Supply Current	White	-	(0.16)	(0.21)	A	(3)a
	Black	-	(0.22)	(0.27)	A	(3)b
	Vertical Stripe	-	(0.27)	(0.32)	A	(3)c
Power Consumption	PLCD	-	(1.35)	(2.52)	Watt	(4)
LVDS differential input voltage	V <sub>id</sub>	-	(1.35)	(1.60)	mV	
LVDS common input voltage	V <sub>ic</sub>	(200)	-	(600)	V	
Logic High Input Voltage	V <sub>IH</sub>	-	(1.2)	-	V	
Logic Low Input Voltage	V <sub>IL</sub>	(2.7)		(3.3)	V	

Note (1) The ambient temperature is  $T_a = 25 \pm 2$  °C.

Note (2) Measurement Conditions:

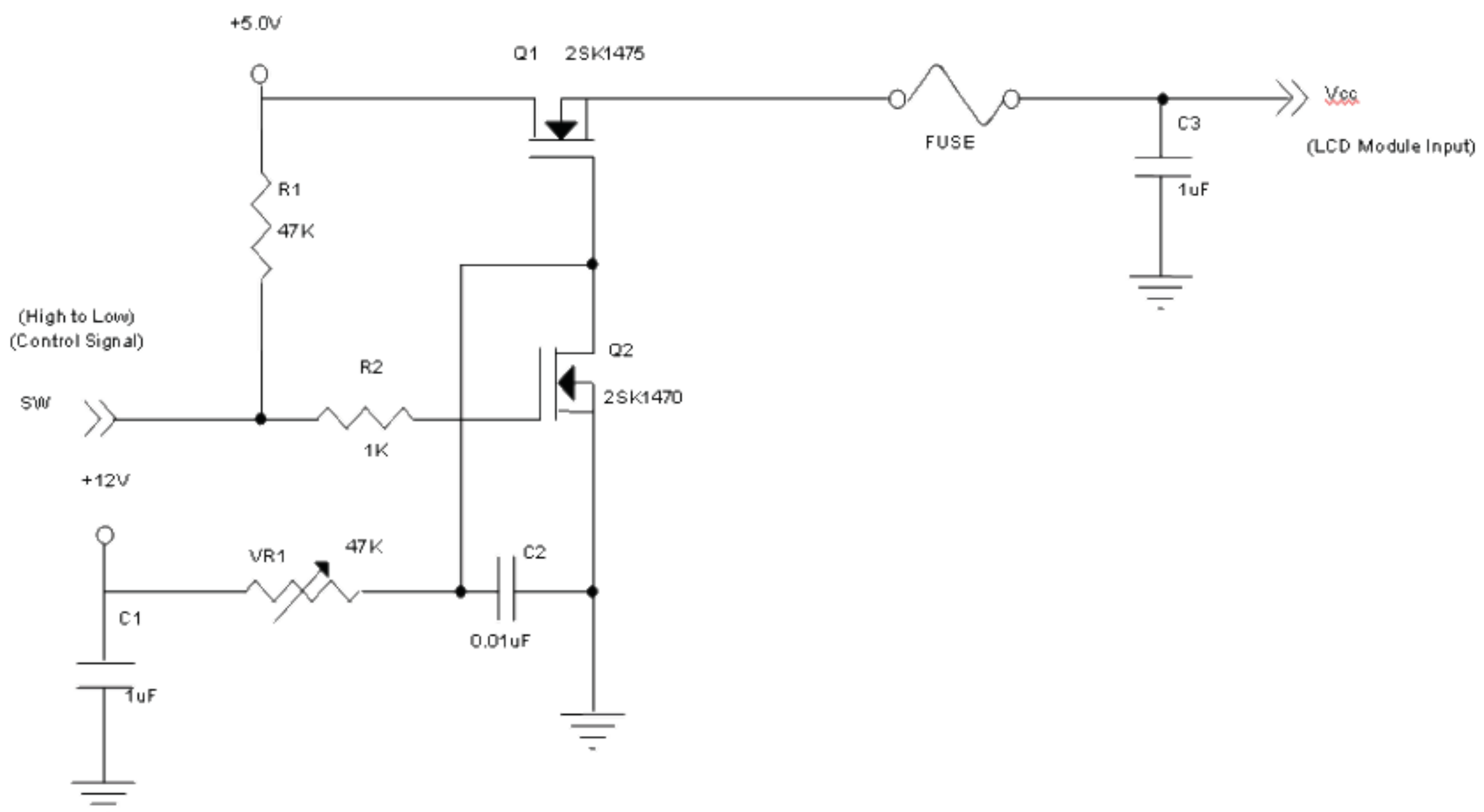

**V<sub>CC</sub> rising time is 470μs**

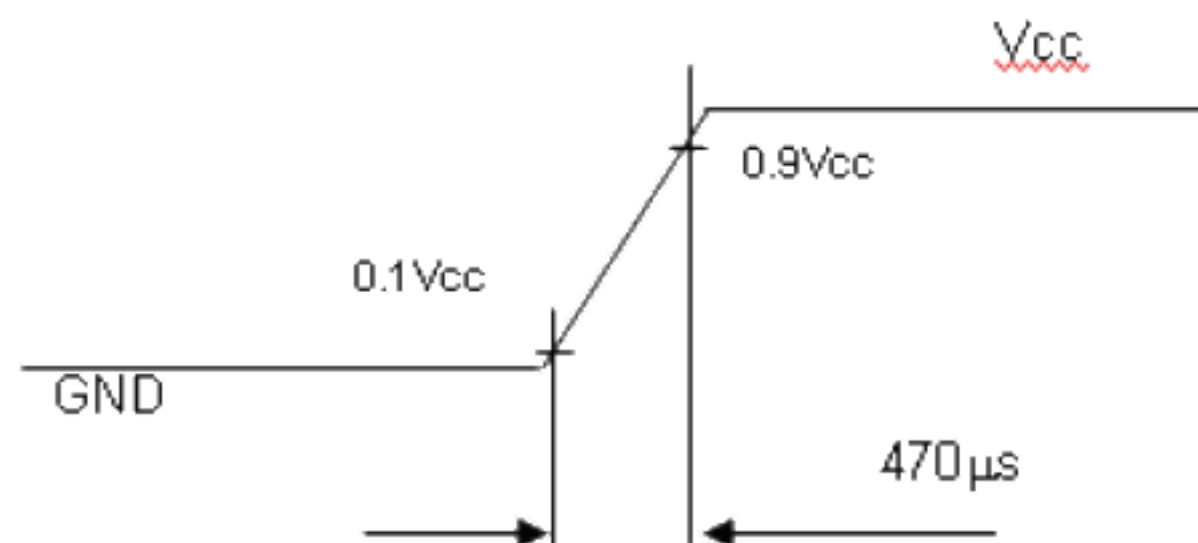



Note (3) The specified power supply current is under the conditions at  $V_{cc} = 5.0\text{ V}$ ,  $T_a = 25 \pm 2\text{ }^\circ\text{C}$ ,  $F_r = 60\text{ Hz}$ , whereas a power dissipation check pattern below is displayed.

a. White Pattern



Active Area

b. Black Pattern

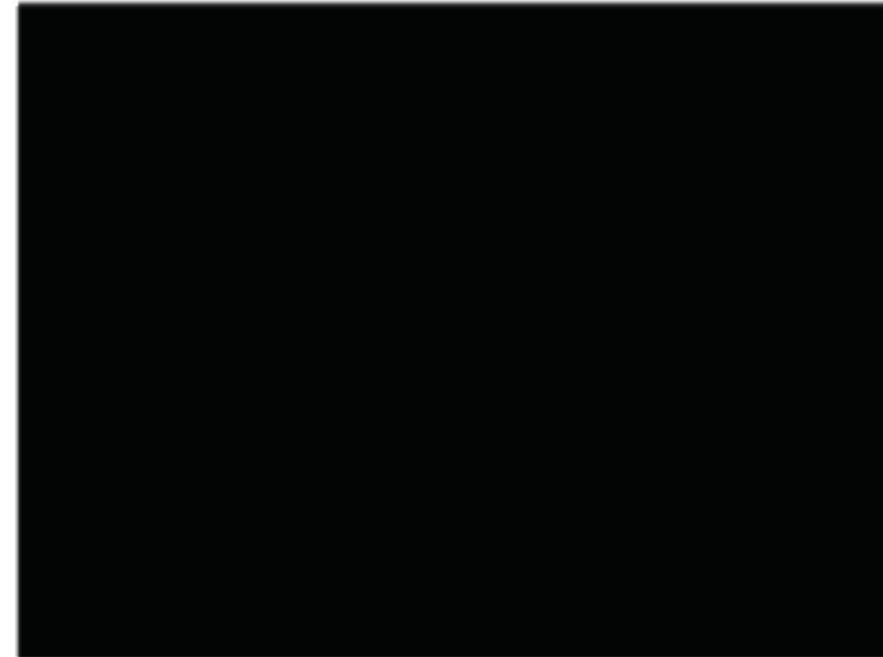

Active Area

c. Vertical Stripe Pattern

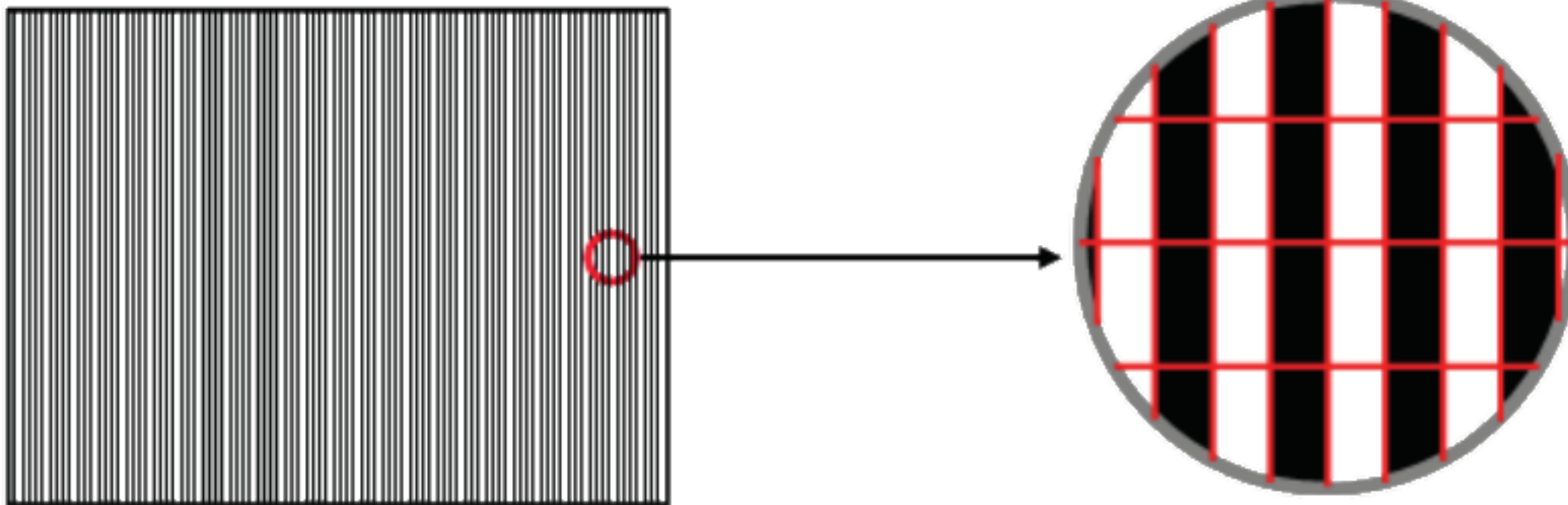

Active Area

Note (4) The power consumption is specified at the pattern with the maximum current.

Note (5) VID waveform condition

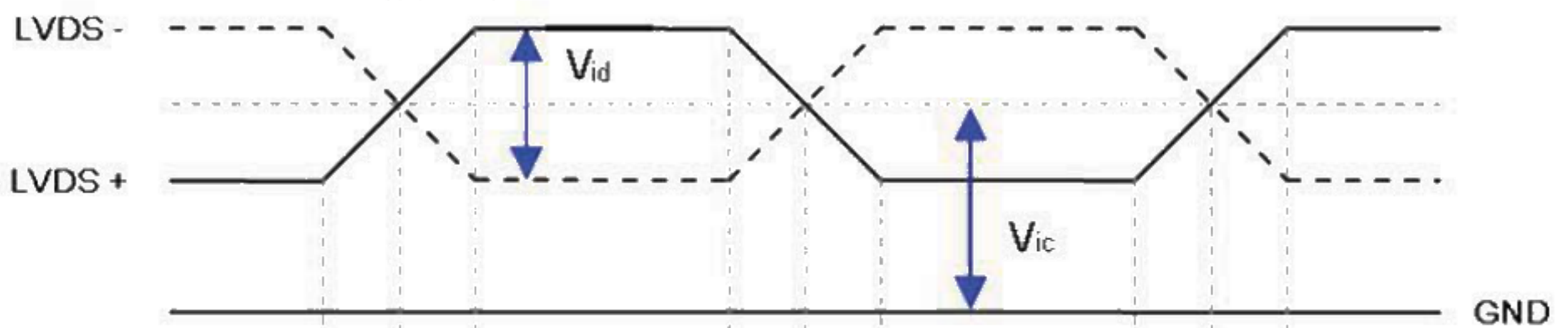

### 4.3.2 Vcc Power Dip Condition

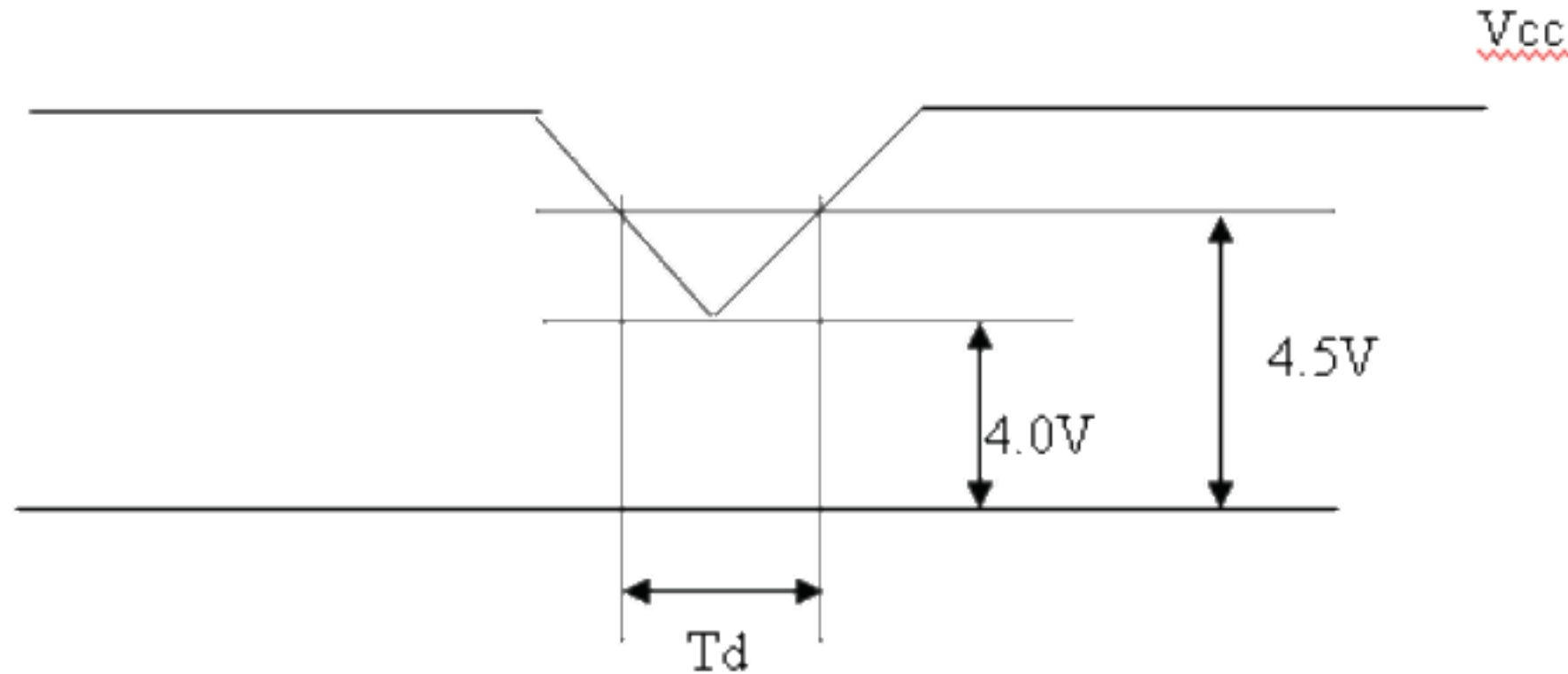

### 4.3.3 BACKLIGHT UNIT

Parameter	Symbol	Value			Unit	Note	
		Min.	Typ.	Max.			
Converter Power Supply Voltage	LED_Vin	(10.8)	(12.0)	(13.2)	V		
Converter Power Supply Current	li	(0.6)	(0.8)	(1)	A	@LED_Vin= 12V Duty=100%	
Converter Input Rush Current	lirsh			(3)	A	@LED_Vin rising = 1mS	
Power Consumption	$P_{LED}$		(9.6)		W	@ LED_Vin = 12V Duty=100%	
EN Control Level	Backlight on	LED_EN	(2.0)	(5)	(5.5)	V	
	Backlight off		(0)	(0)	(0.8)		
PWM Control Level	PWM High Level	LED_PWM	(2.0)	(3.3)	(5.0)	V	
	PWM Low Level		(0)	(0)	(0.15)		
PWM Control Duty Ratio			(10)	--	(100)	%	
PWM Control Frequency	$f_{PWM}$		(190)	(200)	(20k)	Hz	
LED Life Time	$L_L$		(50,000)			Hrs	(2)

Note (1) LED light bar input voltage and current are measured by utilizing a true RMS multimeter as shown below:

Note (2) The lifetime of LED is defined as the time when LED packages continue to operate under the conditions at  $T_a = 25 \pm 2 \text{ }^\circ\text{C}$  and  $I = (60)\text{mA}$  (per chip) until the brightness becomes  $\leq 50\%$  of its original value.

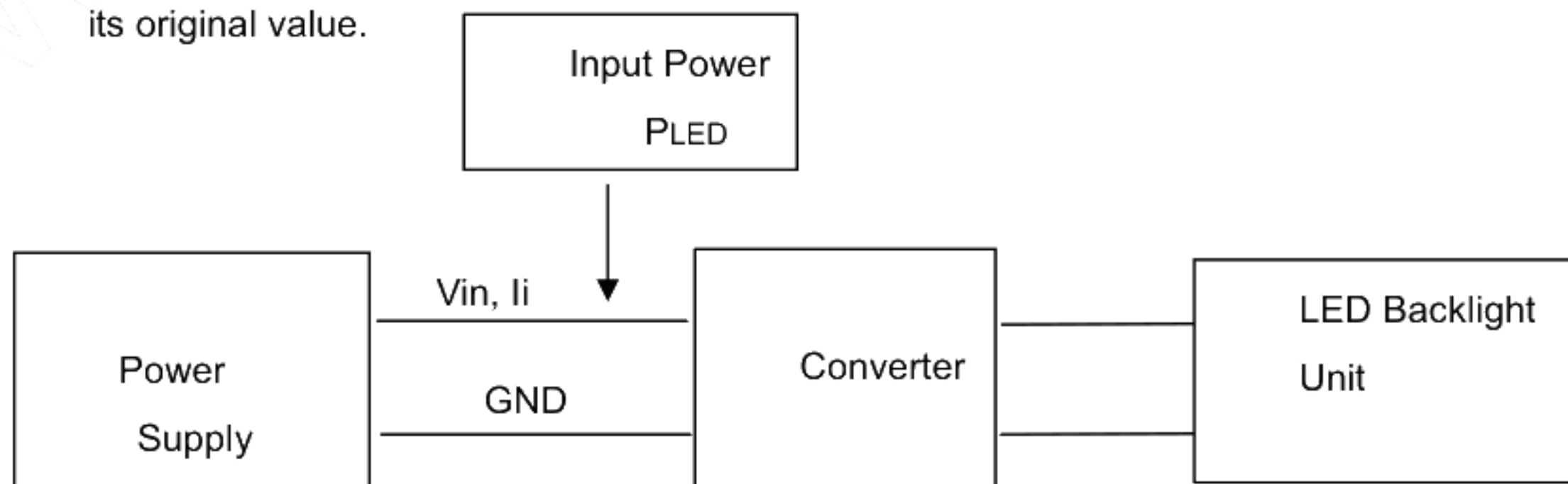

## 4.3.4 BACKLIGHT PIN ASSIGNMENT

Pin	Symbol	Description	Remark
1	$V_i$	Converter input voltage	12V
2	$V_{GND}$	Converter ground	Ground
3	EN	Enable pin	3.3 / 5 V
4	ADJ	Backlight Adjust	PWM Dimming (Hi: 3.3 / 5V <sub>DC</sub> , Lo: 0V <sub>DC</sub> )
5	NC	Not Connect	

Note (1) Connector Part No.:

CI4205M2HRP-NH,CVILUX

## 4.4 LVDS INPUT SIGNAL SPECIFICATIONS

### 4.4.1 LVDS DATA MAPPING TABLE

LVDS Channel 0	LVDS output	D7	D6	D4	D3	D2	D1	D0
	Data order	G0	R5	R4	R3	R2	R1	R0
LVDS Channel 1	LVDS output	D18	D15	D14	D13	D12	D9	D8
	<b>Data order</b>	B1	B0	G5	G4	G3	G2	G1
LVDS Channel 2	LVDS output	D26	D25	D24	D22	D21	D20	D19
	Data order	DE	NA	NA	B5	B4	B3	B2
LVDS Channel 3	LVDS output	D23	D17	D16	D11	D10	D5	D27
	Data order	NA	B7	B6	G7	G6	R7	R6



## 4.4.2 COLOR DATA INPUT ASSIGNMENT

The brightness of each primary color (red, green and blue) is based on the 8-bit gray scale data input for the color. The higher the binary input, the brighter the color. The table below provides the assignment of color versus data input.

Color		Data Signal																							
		Red								Green								Blue							
		R7	R6	R5	R4	R3	R2	R1	R0	G7	G6	G5	G4	G3	G2	G1	G0	B7	B6	B5	B4	B3	B2	B1	B0
Basic Colors	Black	0	0	0	0	0	0	0	0	0	0	0	0	0	0	0	0	0	0	0	0	0	0	0	0
	Red	1	1	1	1	1	1	1	1	0	0	0	0	0	0	0	0	0	0	0	0	0	0	0	0
	Green	0	0	0	0	0	0	0	0	1	1	1	1	1	1	1	1	0	0	0	0	0	0	0	0
	Blue	0	0	0	0	0	0	0	0	0	0	0	0	0	0	0	0	1	1	1	1	1	1	1	1
	Cyan	0	0	0	0	0	0	0	0	1	1	1	1	1	1	1	1	1	1	1	1	1	1	1	1
	Magenta	1	1	1	1	1	1	1	1	0	0	0	0	0	0	0	0	1	1	1	1	1	1	1	1
	Yellow	1	1	1	1	1	1	1	1	1	1	1	1	1	1	1	0	0	0	0	0	0	0	0	0
	White	1	1	1	1	1	1	1	1	1	1	1	1	1	1	1	1	1	1	1	1	1	1	1	1
Gray Scale Of Red	Red(0) / Dark	0	0	0	0	0	0	0	0	0	0	0	0	0	0	0	0	0	0	0	0	0	0	0	
	Red(1)	0	0	0	0	0	0	0	1	0	0	0	0	0	0	0	0	0	0	0	0	0	0	0	
	Red(2)	0	0	0	0	0	0	1	0	0	0	0	0	0	0	0	0	0	0	0	0	0	0	0	
	⋮	⋮	⋮	⋮	⋮	⋮	⋮	⋮	⋮	⋮	⋮	⋮	⋮	⋮	⋮	⋮	⋮	⋮	⋮	⋮	⋮	⋮	⋮		
	⋮	⋮	⋮	⋮	⋮	⋮	⋮	⋮	⋮	⋮	⋮	⋮	⋮	⋮	⋮	⋮	⋮	⋮	⋮	⋮	⋮	⋮	⋮		
	Red(253)	1	1	1	1	1	1	0	1	0	0	0	0	0	0	0	0	0	0	0	0	0	0	0	
	Red(254)	1	1	1	1	1	1	1	0	0	0	0	0	0	0	0	0	0	0	0	0	0	0	0	
	Red(255)	1	1	1	1	1	1	1	1	0	0	0	0	0	0	0	0	0	0	0	0	0	0	0	
Gray Scale Of Green	Green(0) / Dark	0	0	0	0	0	0	0	0	0	0	0	0	0	0	0	0	0	0	0	0	0	0	0	
	Green(1)	0	0	0	0	0	0	0	0	0	0	0	0	0	0	1	0	0	0	0	0	0	0	0	
	Green(2)	0	0	0	0	0	0	0	0	0	0	0	0	0	0	1	0	0	0	0	0	0	0	0	
	⋮	⋮	⋮	⋮	⋮	⋮	⋮	⋮	⋮	⋮	⋮	⋮	⋮	⋮	⋮	⋮	⋮	⋮	⋮	⋮	⋮	⋮	⋮		
	⋮	⋮	⋮	⋮	⋮	⋮	⋮	⋮	⋮	⋮	⋮	⋮	⋮	⋮	⋮	⋮	⋮	⋮	⋮	⋮	⋮	⋮	⋮		
	Green(253)	0	0	0	0	0	0	0	0	1	1	1	1	1	1	0	1	0	0	0	0	0	0	0	
	Green(254)	0	0	0	0	0	0	0	0	1	1	1	1	1	1	0	0	0	0	0	0	0	0	0	
	Green(255)	0	0	0	0	0	0	0	0	1	1	1	1	1	1	1	0	0	0	0	0	0	0	0	
Gray Scale Of Blue	Blue(0) / Dark	0	0	0	0	0	0	0	0	0	0	0	0	0	0	0	0	0	0	0	0	0	0	0	
	Blue(1)	0	0	0	0	0	0	0	0	0	0	0	0	0	0	0	0	0	0	0	0	0	0	1	
	Blue(2)	0	0	0	0	0	0	0	0	0	0	0	0	0	0	0	0	0	0	0	0	0	1	0	
	⋮	⋮	⋮	⋮	⋮	⋮	⋮	⋮	⋮	⋮	⋮	⋮	⋮	⋮	⋮	⋮	⋮	⋮	⋮	⋮	⋮	⋮	⋮		
	⋮	⋮	⋮	⋮	⋮	⋮	⋮	⋮	⋮	⋮	⋮	⋮	⋮	⋮	⋮	⋮	⋮	⋮	⋮	⋮	⋮	⋮	⋮		
	Blue(253)	0	0	0	0	0	0	0	0	0	0	0	0	0	0	0	1	1	1	1	1	1	0	1	
	Blue(254)	0	0	0	0	0	0	0	0	0	0	0	0	0	0	0	1	1	1	1	1	1	1	0	
	Blue(255)	0	0	0	0	0	0	0	0	0	0	0	0	0	0	0	1	1	1	1	1	1	1	1	

Note (1) 0: Low Level Voltage, 1: High Level Voltage

## 4.5 DISPLAY TIMING SPECIFICATIONS

The input signal timing specifications are shown as the following table and timing diagram.

Signal	Item	Symbol	Min.	Typ.	Max.	Unit	Note
LVDS Clock	Frequency	F <sub>c</sub>	(63)	(76)	(96)	MHz	-
	Period	T <sub>c</sub>		(13)		ns	
	Input cycle to cycle jitter	T <sub>rcj</sub>	(TC -200)		(TC +200)	ns	(1)
	Input Clock to data skew	TLVCCS			(400)	ps	(2)
	Spread spectrum modulation range	F <sub>clkin_mod</sub>	(FC*97%)		(FC*103%)	MHz	(3)
	Spread spectrum modulation frequency	F <sub>SSM</sub>			(200)	KHz	
Vertical Display Term	Frame Rate	Fr	(50)	(60)	(76)	Hz	T <sub>v</sub> =T <sub>vd</sub> +T <sub>vb</sub>
	Total	T <sub>v</sub>	(800)	(806)	(815)	Th	-
	Active Display	T <sub>vd</sub>	(768)	(768)	(768)	Th	-
	Blank	T <sub>vb</sub>	(32)	(38)	(47)	Th	-
Horizontal Display Term	Total	T <sub>h</sub>	(1500)	(1560)	(1570)	T <sub>c</sub>	T <sub>h</sub> =T <sub>hd</sub> +T <sub>hb</sub>
	Active Display	T <sub>hd</sub>	(1366)	(1366)	(1366)	T <sub>c</sub>	-
	Blank	T <sub>hb</sub>	(134)	(194)	(204)	T <sub>c</sub>	-

Note: Because this module is operated by DE only mode, Hsync and Vsync input signals are ignored.

### INPUT SIGNAL TIMING DIAGRAM

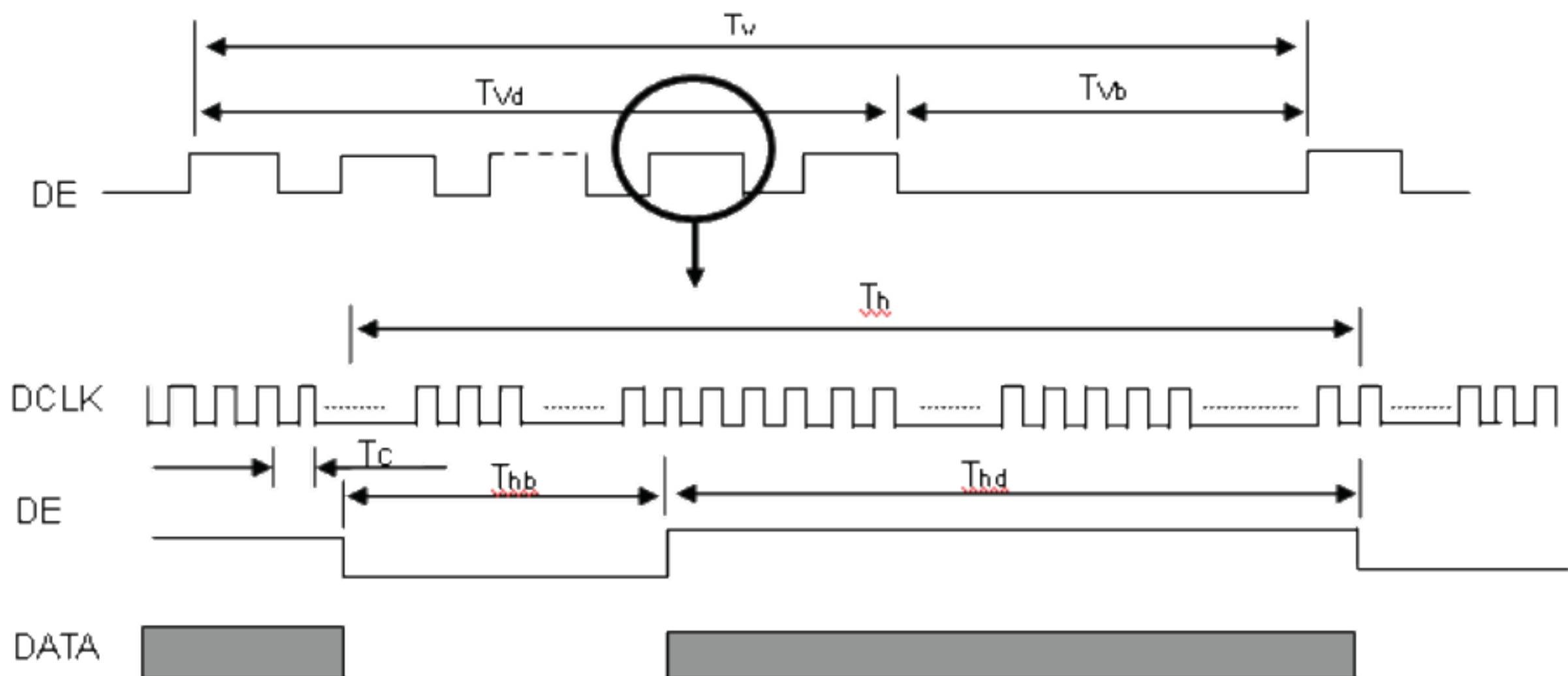



Note (1) The input clock cycle-to-cycle jitter is defined as below figures.  $Trcl = |T_1 - T_1|$

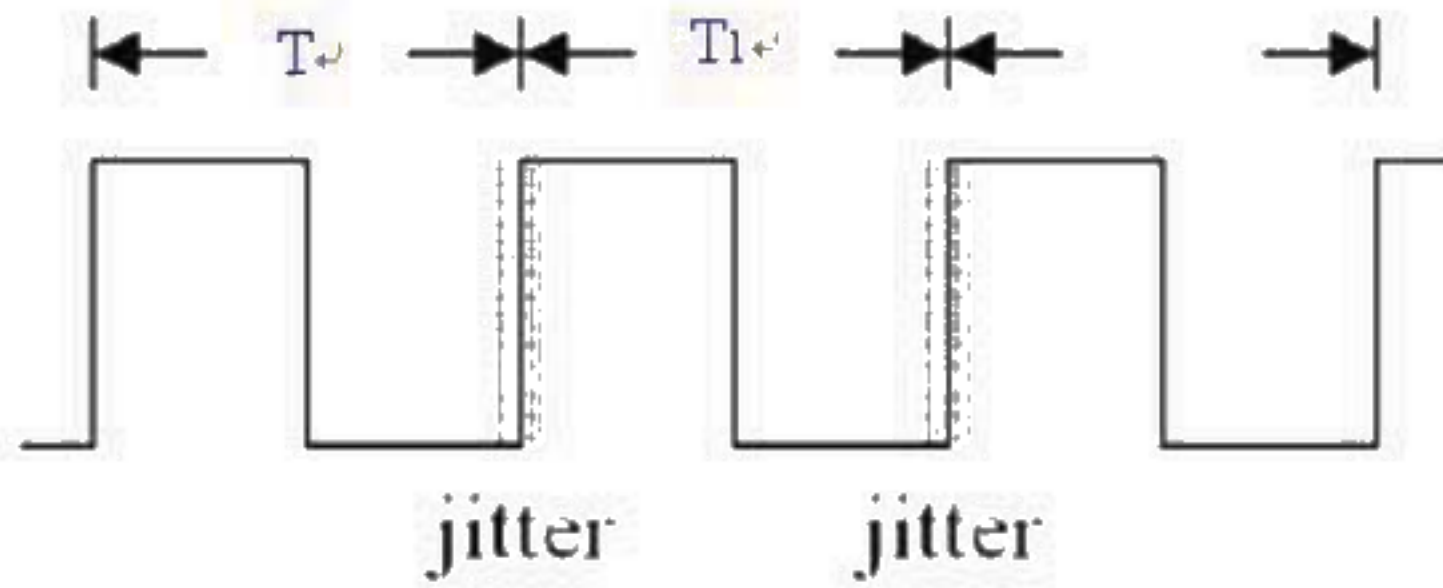

Note (2) Input Clock to data skew is defined as below figures.

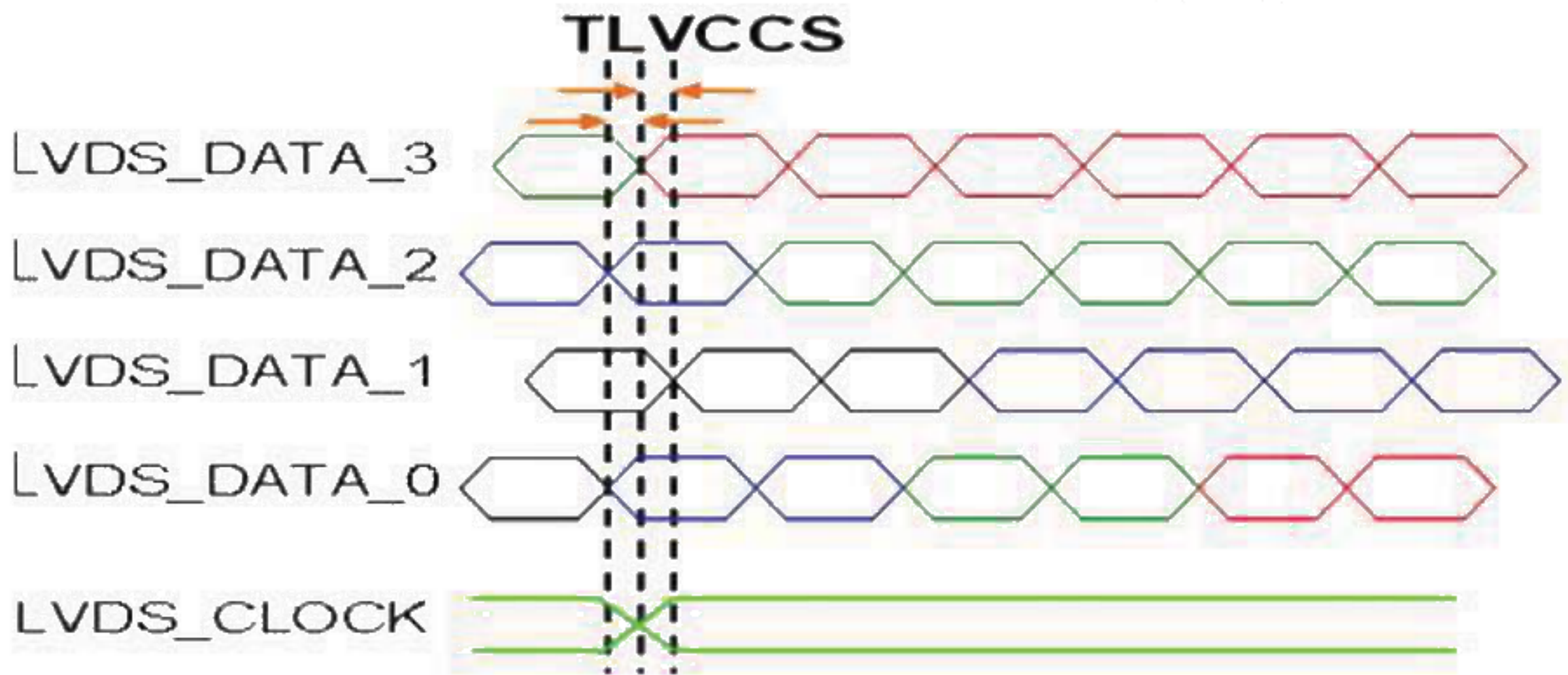

Note (3) The SSCG (Spread spectrum clock generator) is defined as below figures.

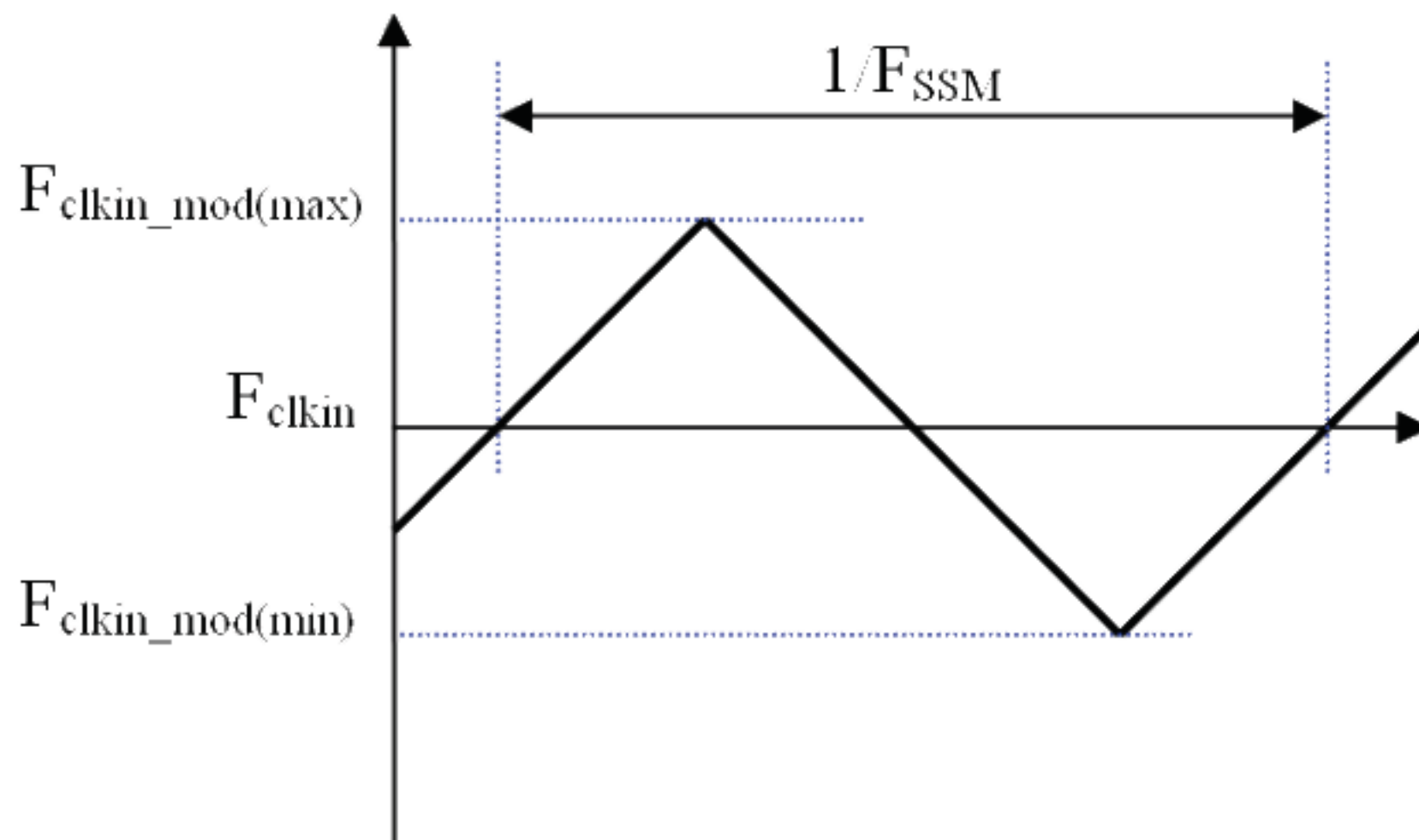



## 4.6 POWER ON/OFF SEQUENCE

The power sequence specifications are shown as the following table and diagram.

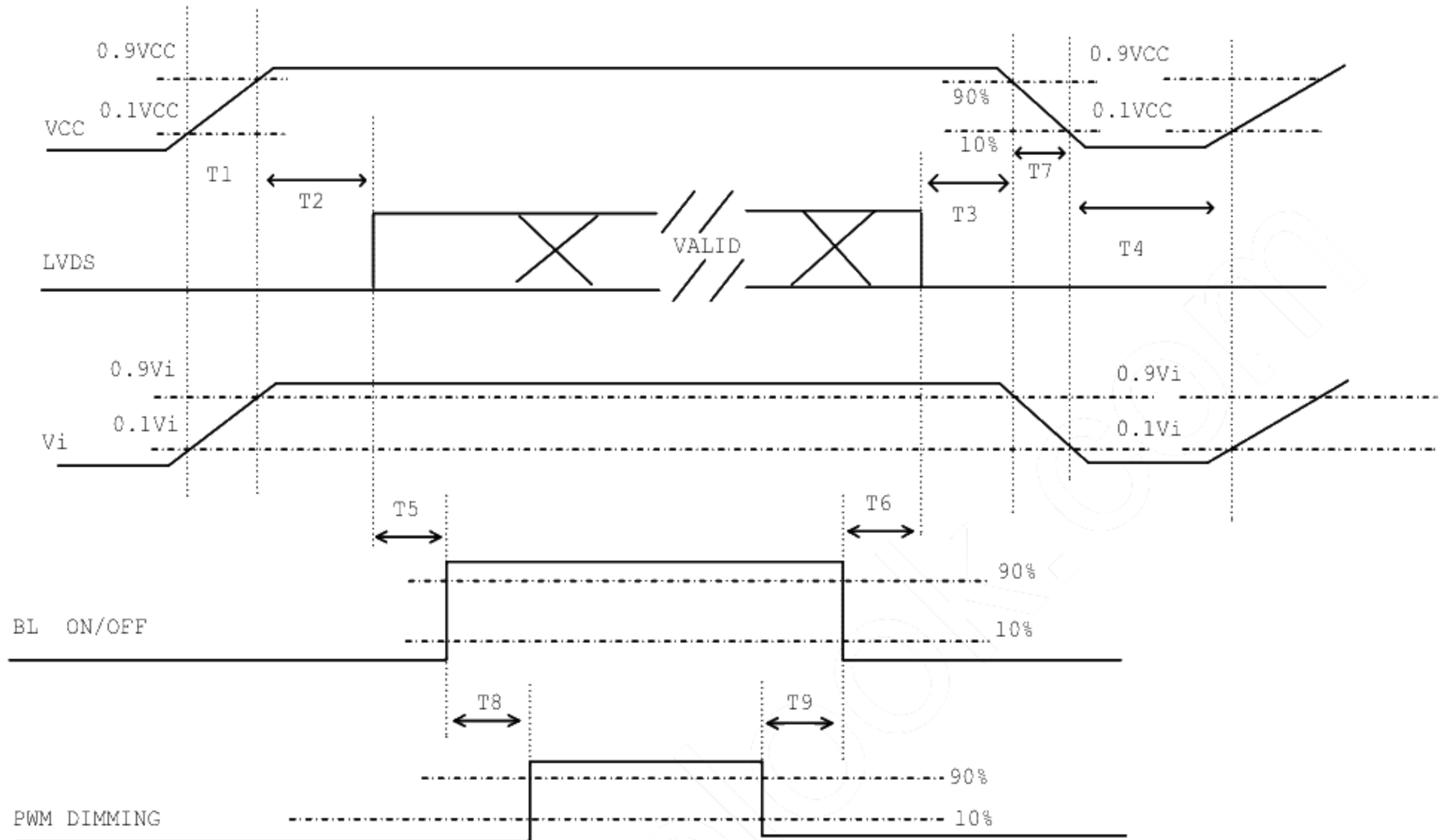

Timing Specifications:

Parameter	Value			Units
	Min	Typ	Max	
T1	0.5	-	10	ms
T2	0	-	50	ms
T3	0	-	50	ms
T4	500	-	-	ms
T5	200	-	-	ms
T6	20	-	-	ms
T7	5	-	300	ms
T8	10	-	-	ms
T9	10	-	-	ms

Note (1) Please avoid floating state of interface signal at invalid period.

Note (2) When the interface signal is invalid, be sure to pull down the power supply of LCD VCC to 0 V.

Note (3) The Backlight converter power must be turned on after the power supply for the logic and the interface signal is valid. The Backlight converter power must be turned off before the power supply for the logic and the interface signal is invalid.

## 5. OPTICAL CHARACTERISTICS

### 5.1 TEST CONDITIONS

Item	Symbol	Value	Unit
Ambient Temperature	Ta	25±2	°C
Ambient Humidity	Ha	50±10	%RH
Supply Voltage	VCC	(3.3)	V
Input Signal	According to typical value in "3. ELECTRICAL CHARACTERISTICS"		
LED Light Bar Input Current Per Input Pin	IPIN	(60 ±1.95)	mADC
PWM Duty Ratio	D	100	%
LED Light Bar Test Converter	CMI 35-D065452		

### 5.2 OPTICAL SPECIFICATIONS

The relative measurement methods of optical characteristics are shown in 5.2. The following items should be measured under the test conditions described in 5.1 and stable environment shown in Note (5).

Item	Symbol	Condition	Min.	Typ.	Max.	Unit	Note	
Color Chromaticity (CIE 1931)	Red	Rx	$\theta_x=0^\circ, \theta_y=0^\circ$ CS-2000 R=G=B=255 Gray scale	Typ - 0.045	(0.617)	Typ + 0.045	-	(1), (5)
		Ry			(0.340)			
	Green	Gx			(0.320)			
		Gy			(0.598)			
	Blue	Bx			(0.160)			
		By			(0.084)			
	White	Wx			(0.313)			
		Wy			(0.329)			
Center Luminance of White (Center of Screen)	L <sub>c</sub>		240	300	-	cd/m <sup>2</sup>	(4), (5)	
Contrast Ratio	CR		400	500	-	-	(2), (5)	
Response Time	T <sub>R</sub>	$\theta_x=0^\circ, \theta_y=0^\circ$	-	(3)	(8)	ms	(3)	
	T <sub>F</sub>			(7)	(13)			
White Variation	W	$\theta_x=0^\circ, \theta_y=0^\circ$	(65)	-	-	%	(5), (6)	
Viewing Angle	Horizontal	$\theta_{x-} + \theta_{x+}$	CR ≥ 10	(140)	(160)	Deg.	(1), (5)	
	Vertical	$\theta_{y-} + \theta_{y+}$		(140)	(160)			



Note (1) Definition of Viewing Angle ( $\theta_x, \theta_y$ ):

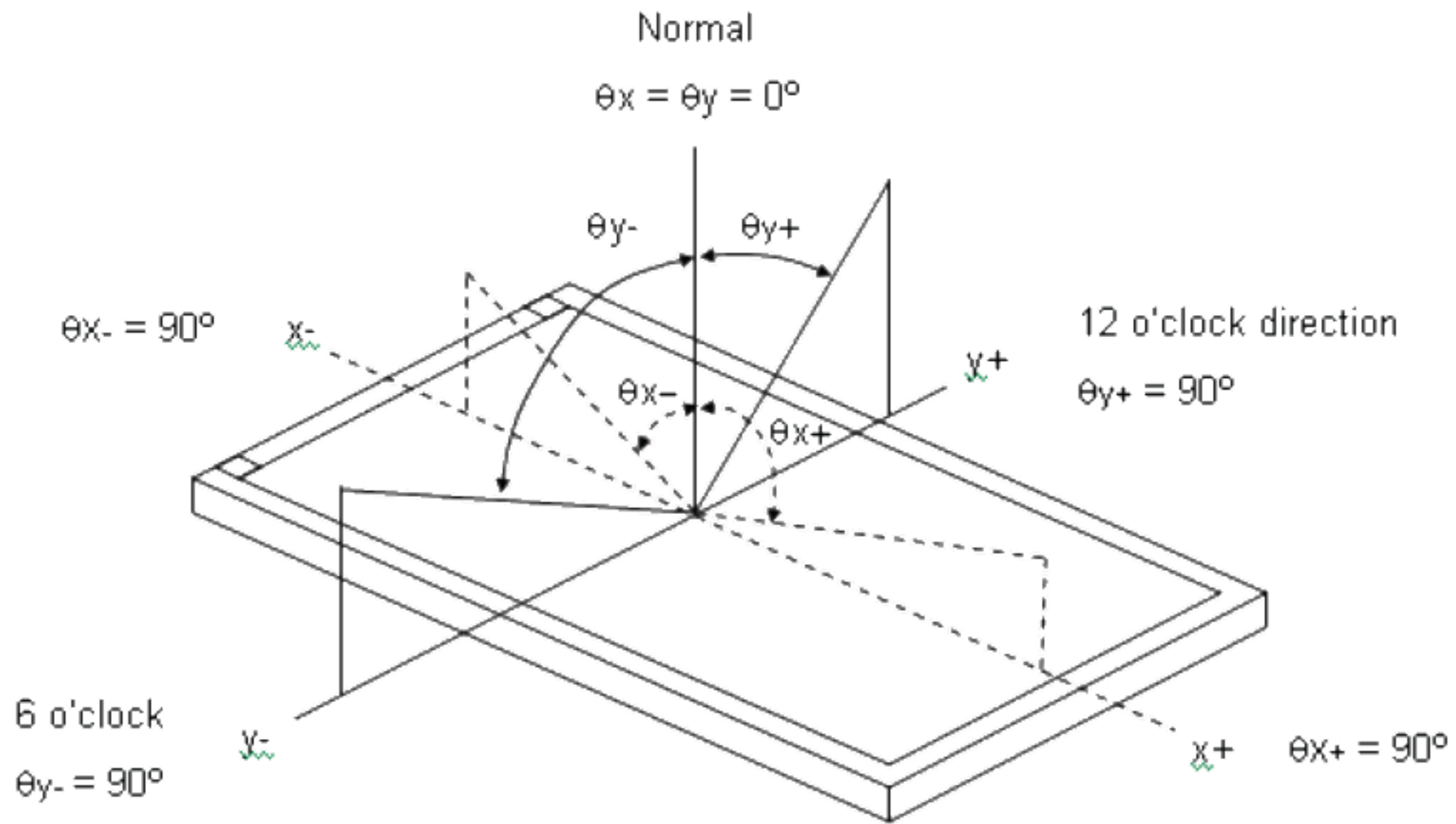

Note (2) Definition of Contrast Ratio (CR):

The contrast ratio can be calculated by the following expression.

$$\text{Contrast Ratio (CR)} = L_{255} / L_0$$

L255: Luminance of gray level 255

L 0: Luminance of gray level 0

$$\text{CR} = \text{CR} (5)$$

CR (X) is corresponding to the Contrast Ratio of the point X at Figure in Note (6).

Note (3) Definition of Response Time ( $T_R, T_F$ ):

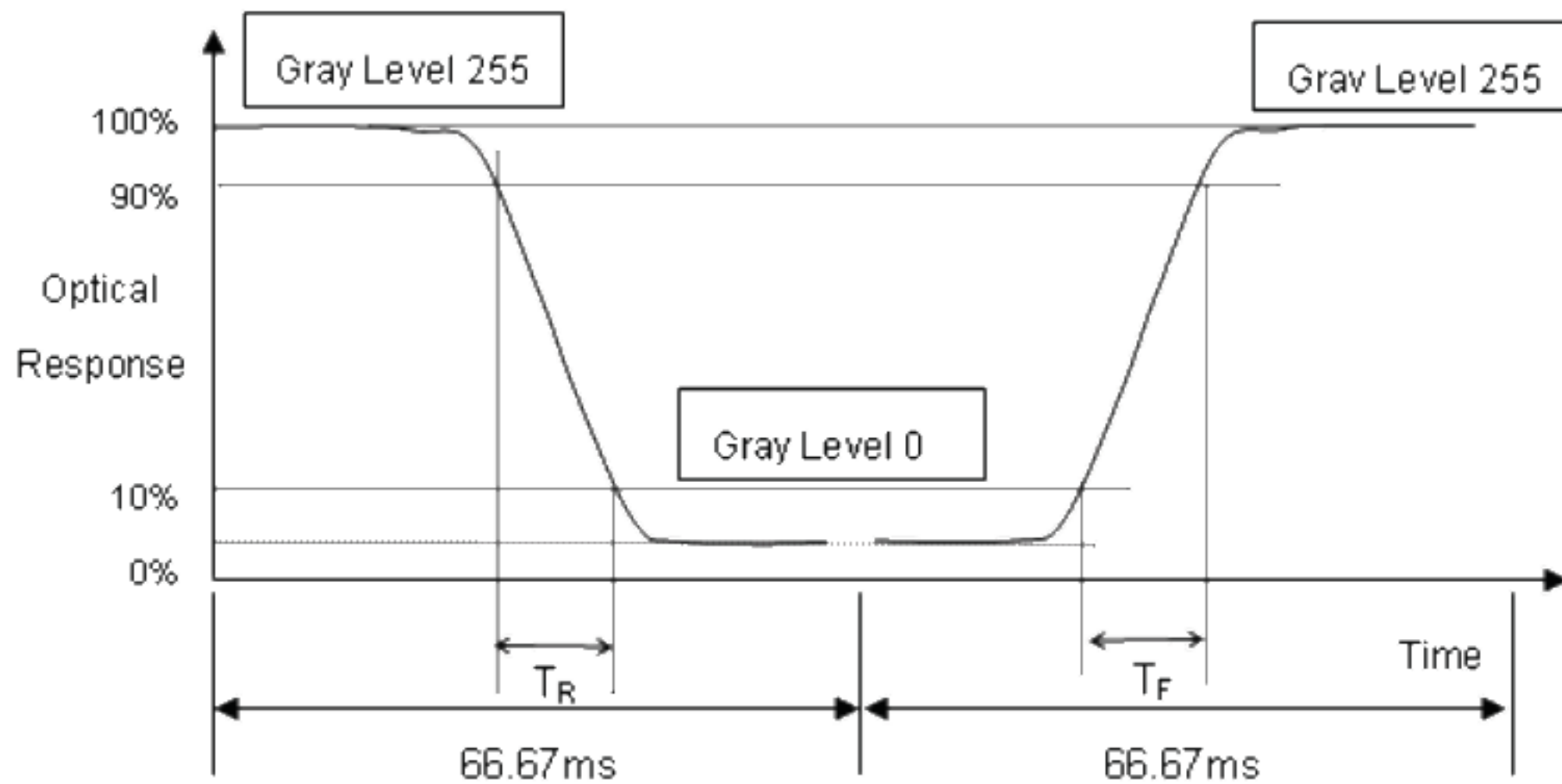



Note (4) Definition of Luminance of White ( $L_C$ ):

Measure the luminance of gray level 255 at center point

$$L_C = L(5)$$

$L(x)$  is corresponding to the luminance of the point X at Figure in Note (6).

Note (5) Measurement Setup:

The LCD module should be stabilized at given temperature for 40 minutes to avoid abrupt temperature change during measuring. In order to stabilize the luminance, the measurement should be executed after lighting Backlight for 40 minutes in a windless room.

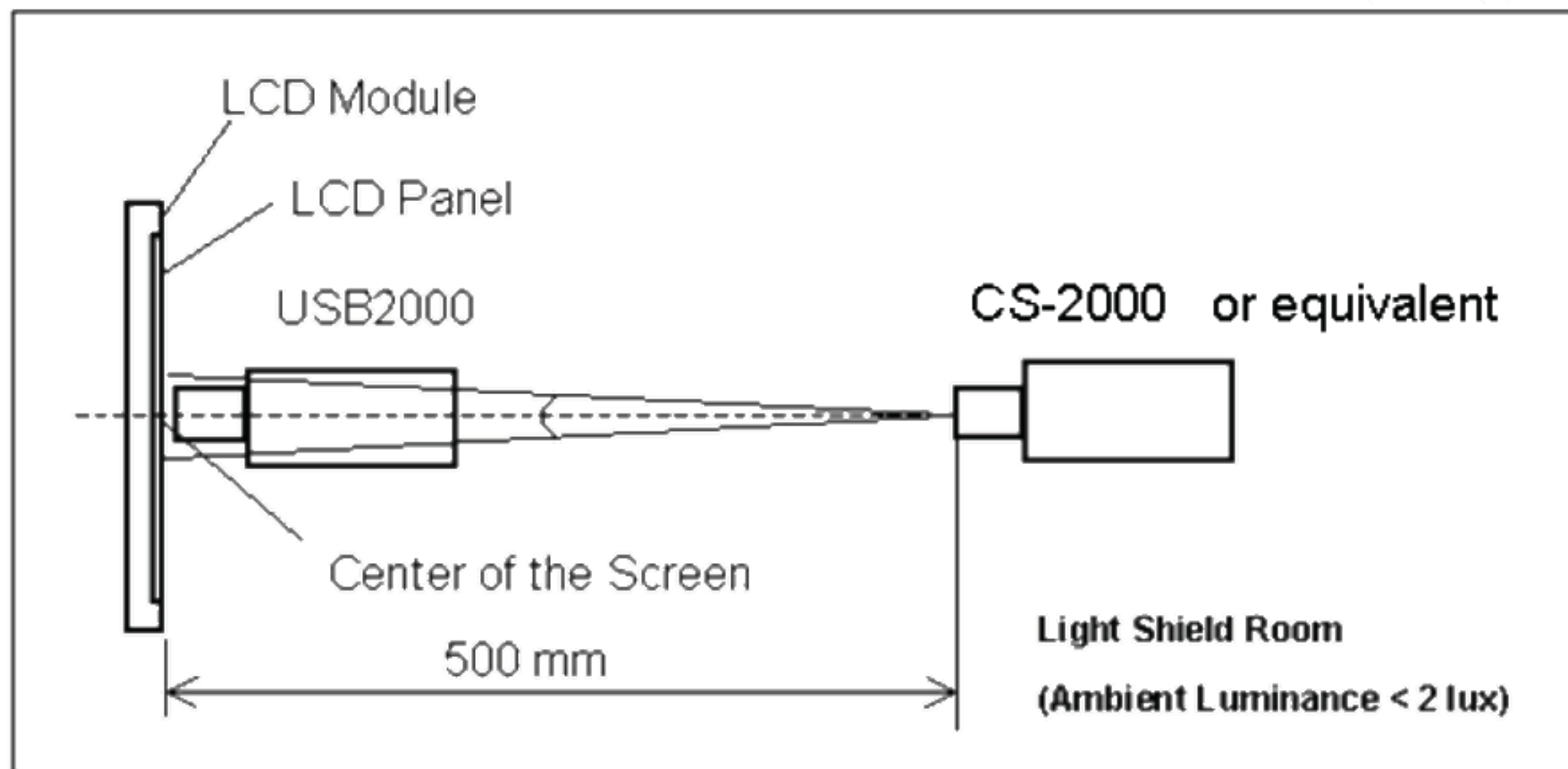

Note (6) Definition of White Variation ( $\delta W$ ):

Measure the luminance of gray level 255 at 9 points

$$\delta W = ( \text{Minimum} [L(1) \sim L(9)] / \text{Maximum} [L(1) \sim L(9)] ) * 100\%$$

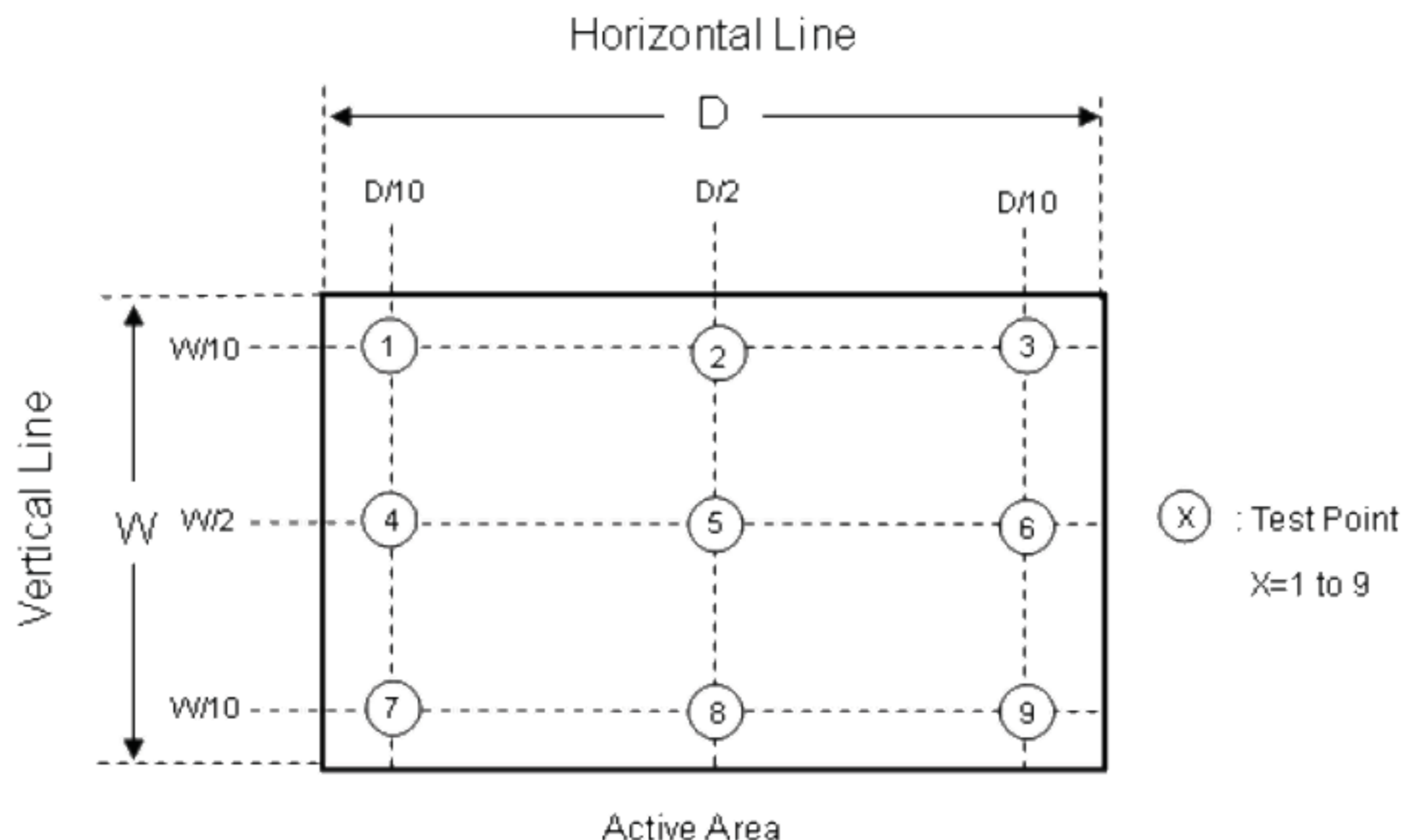

## 6. RELIABILITY TEST ITEM

Items	Required Condition	Note
Temperature Humidity Bias (THB)	Ta= 50°C , 80%RH, 240hours	
High Temperature Operation (HTO)	Ta= 60°C , 50%RH , 240hours	
Low Temperature Operation (LTO)	Ta= 0°C , 240hours	
High Temperature Storage (HTS)	Ta= 60°C , 240hours	
Low Temperature Storage (LTS)	Ta= -20°C , 240hours	
Vibration Test (Non-operation)	Acceleration: 1.5 Grms Wave: Half-sine Frequency: 10 - 300 Hz Sweep: 30 Minutes each Axis (X, Y, Z)	
Shock Test (Non-operation)	Acceleration: 50 G Wave: Half-sine Active Time: 11 ms Direction : ± X, ± Y, ± Z.(one time for each Axis)	
Thermal Shock Test (TST)	-20°C/30min , 60°C / 30min , 100 cycles	
On/Off Test	25°C ,On/10sec , Off /10sec , 30,000 cycles	
ESD (Electro Static Discharge)	Contact Discharge: ± 8KV, 150pF(330Ω) Air Discharge: ± 15KV, 150pF(330Ω)	
Altitude Test	Operation:10,000 ft / 24hours Non-Operation:30,000 ft / 24hours	

Note (1) criteria : Normal display image with no obvious non-uniformity and no line defect.

Note (2) Evaluation should be tested after storage at room temperature for more than two hour

Note (3) At testing Vibration and Shock, the fixture in holding the module has to be hard and rigid enough so that the module would not be twisted or bent by the fixture.

The fixing condition is shown as below:

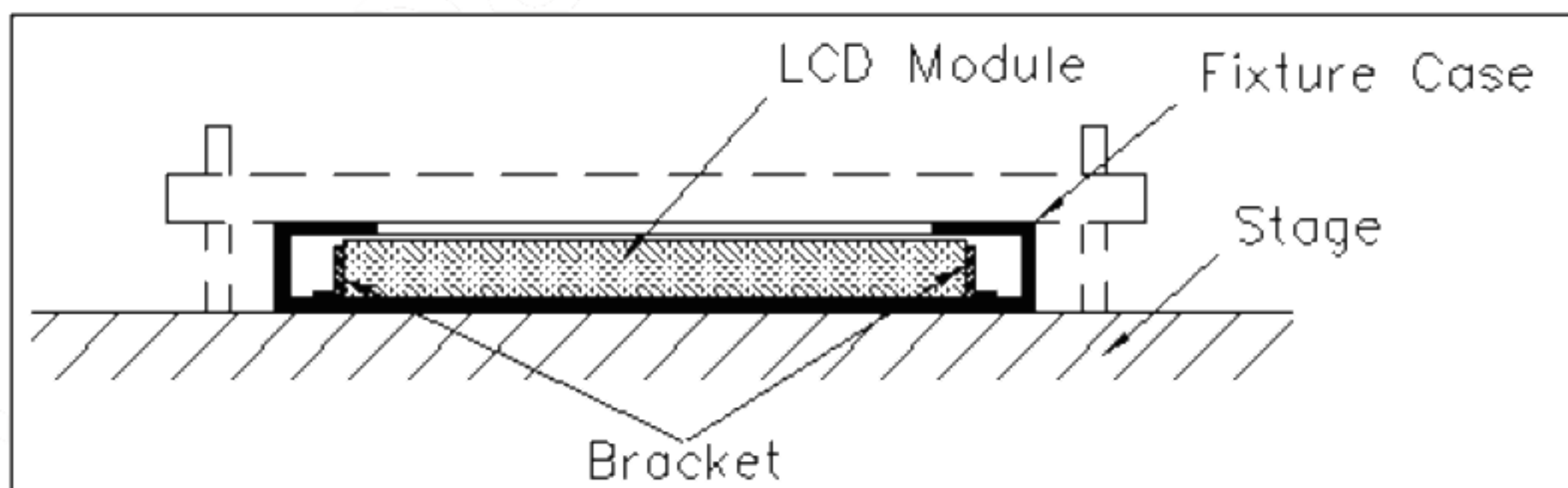

## 7. PACKING

### 7.1 PACKING SPECIFICATIONS

- (1) 10 pcs LCD modules / 1 Box
- (2) Box dimensions: 465 (L) X 362 (W) X 314 (H) mm
- (3) Weight: approximately 17Kg (10 modules per box)

### 7.2 PACKING METHOD

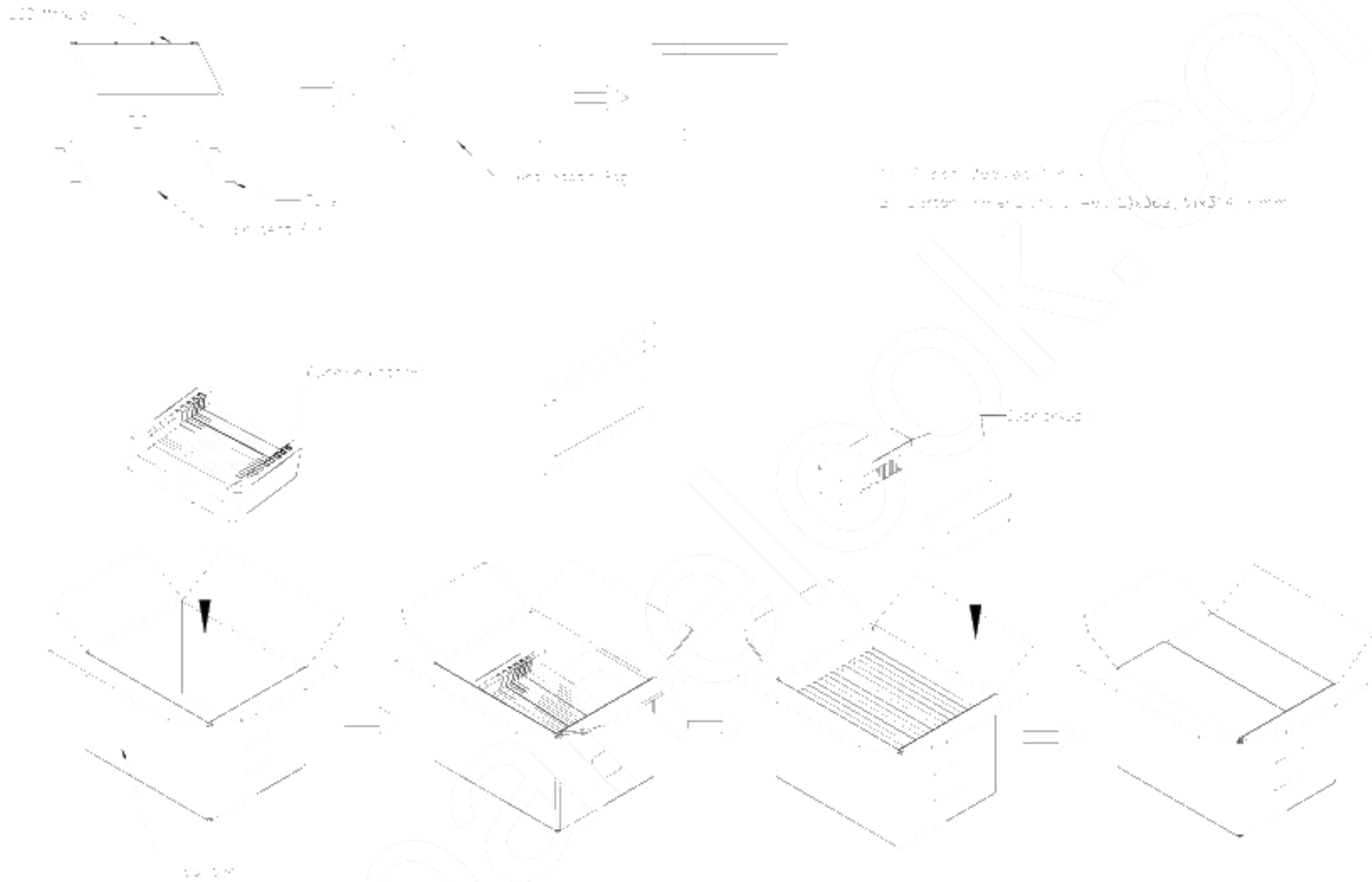
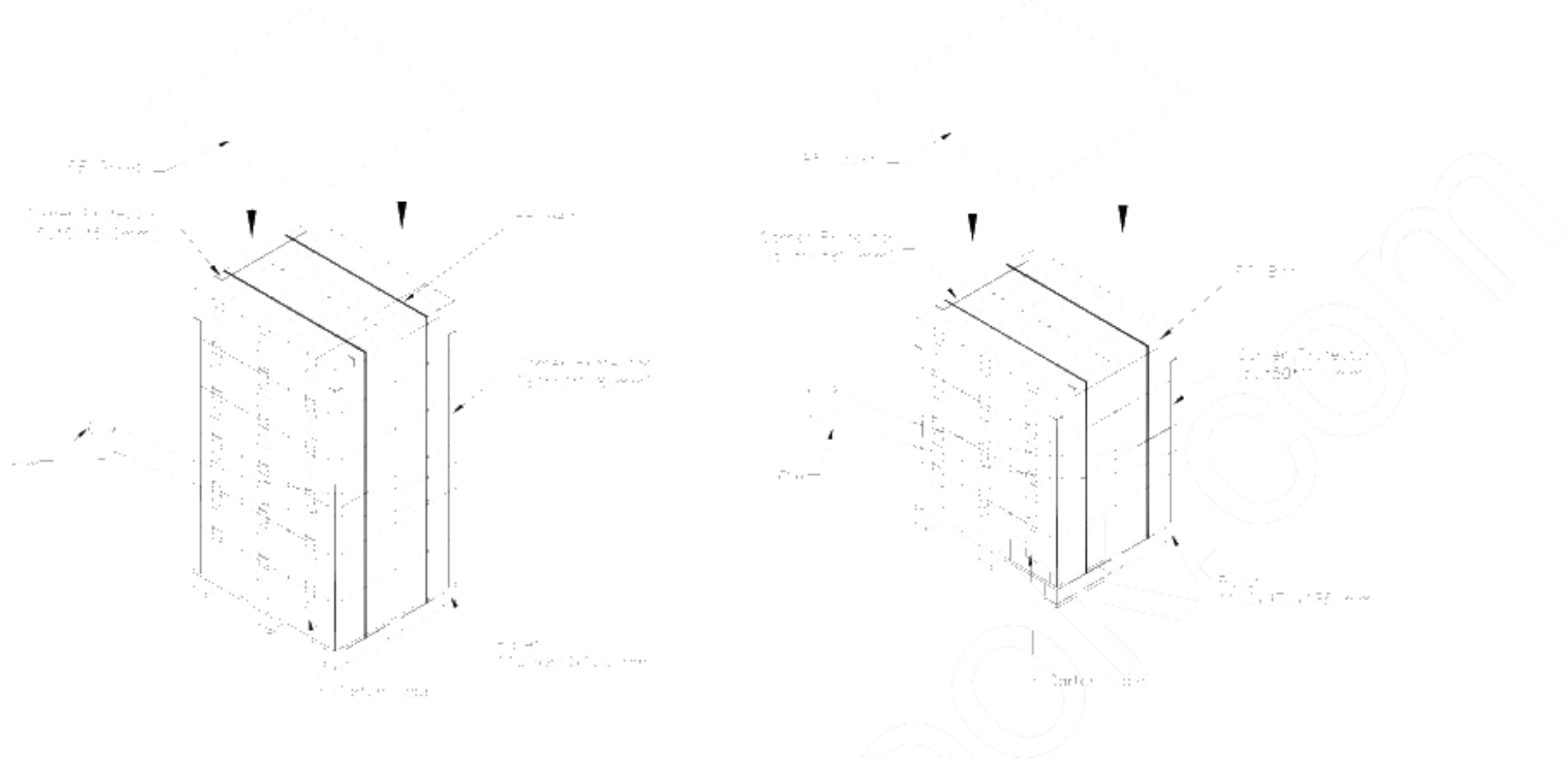

**Figure. 7-1 Packing**



### Sea / Land Transportation (40ft Container)

### Air Transportation



**Figure. 7-2 Packing**

### 7.3 UN-PACKING METHOD

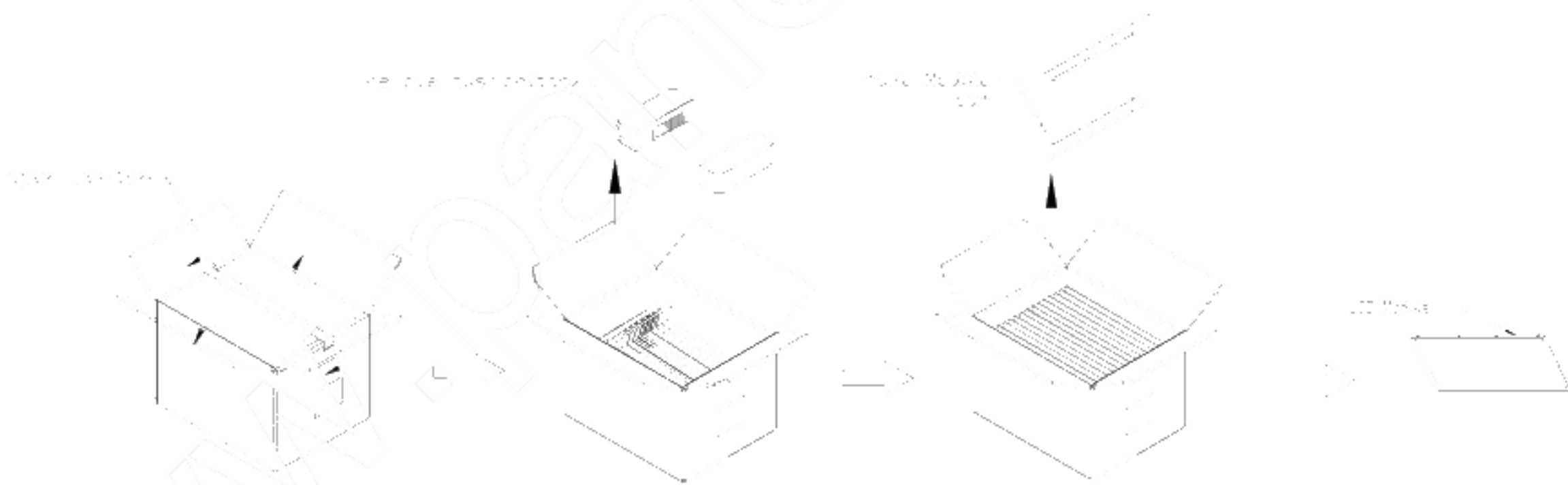
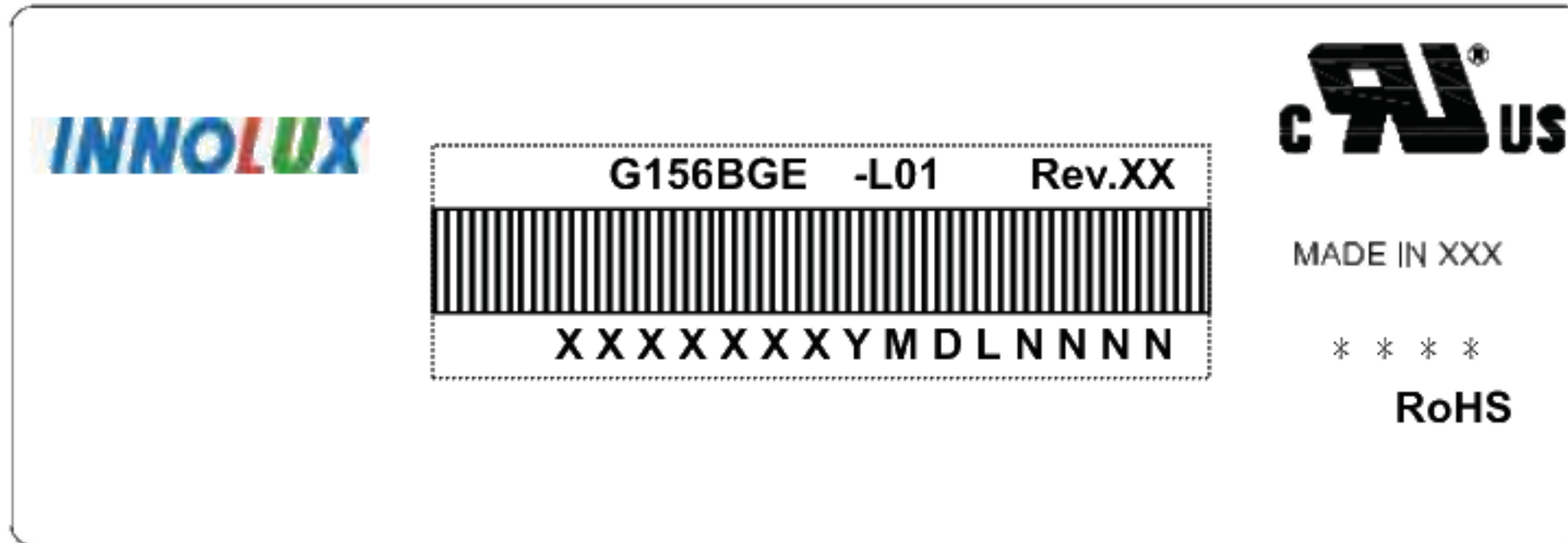

**Figure. 7-3 UN-Packing**

## 8. MODULE LABEL

### 10.1 INX MODULE LABEL

The barcode nameplate is pasted on each module as illustration, and its definitions are as following explanation.



- (a) Model Name: G156BGE -L01
- (b) Revision: Rev. XX, for example: A1, B1, C1, C2 ...etc.
- (c) \* \* \* \* : Factory ID
- (d) Serial ID: X X X X X X X Y M D X N N N N



Serial ID includes the information as below:

- (a) Manufactured Date: Year: 1~9, for 2011~2019  
 Month: 1~9, A~C, for Jan. ~ Dec.  
 Day: 1~9, A~Y, for 1<sup>st</sup> to 31<sup>st</sup>, exclude I, O and U
- (b) Revision Code: cover all the change
- (c) Serial No.: Manufacturing sequence of product

## 9. PRECAUTIONS

### 9.1 ASSEMBLY AND HANDLING PRECAUTIONS

- (1) Do not apply rough force such as bending or twisting to the module during assembly.
- (2) To assemble or install module into user's system can be only in clean working areas. The dust and oil may cause electrical short or worsen the polarizer.
- (3) It's not permitted to have pressure or impulse on the module because the LCD panel and Backlight will be damaged.
- (4) Always follow the correct power sequence when LCD module is connecting and operating. This can prevent damage to the CMOS LSI chips during latch-up.
- (5) Do not pull the I/F connector in or out while the module is operating.
- (6) Do not disassemble the module.
- (7) Use a soft dry cloth without chemicals for cleaning, because the surface of polarizer is very soft and easily scratched.
- (8) It is dangerous that moisture come into or contacted the LCD module, because moisture may damage LCD module when it is operating.
- (9) High temperature or humidity may reduce the performance of module. Please store LCD module within the specified storage conditions.
- (10) When ambient temperature is lower than 10°C may reduce the display quality. For example, the response time will become slowly.

### 9.2 STORAGE PRECAUTIONS

- (1) Do not leave the module in high temperature, and high humidity for a long time. It is highly recommended to store the module with temperature from 0°C to 35°C and relative humidity of less than 70%
- (2) Do not store the TFT – LCD module in direct sunlight
- (3) The module should be stored in dark place. It is prohibited to apply sunlight or fluorescent light in storing

### 9.3 OPERATION PRECAUTIONS

- (1) The LCD product should be operated under normal condition.  
Normal condition is defined as below :  
Temperature : 20±15°C  
Humidity: 65±20%  
Display pattern : continually changing pattern(Not stationary)
- (2) If the product will be used in extreme conditions such as high temperature, high humidity, high altitude, display pattern or operation time etc... It is strongly recommended to contact CMI for application engineering advice. Otherwise, its reliability and function may not be guaranteed.



## 9.4 SAFETY PRECAUTIONS

- (1) If the liquid crystal material leaks from the panel, it should be kept away from the eyes or mouth. In case of contact with hands, skin or clothes, it has to be washed away thoroughly with soap.
- (2) After the module's end of life, it is not harmful in case of normal operation and storage.

## 9.5 SAFETY STANDARDS

The LCD module should be certified with safety regulations as follows:

- (1) UL60950-1 or updated standard.
- (2) IEC60950-1 or updated standard.

## 9.6 OTHER

When fixed patterns are displayed for a long time, remnant image is likely to occur

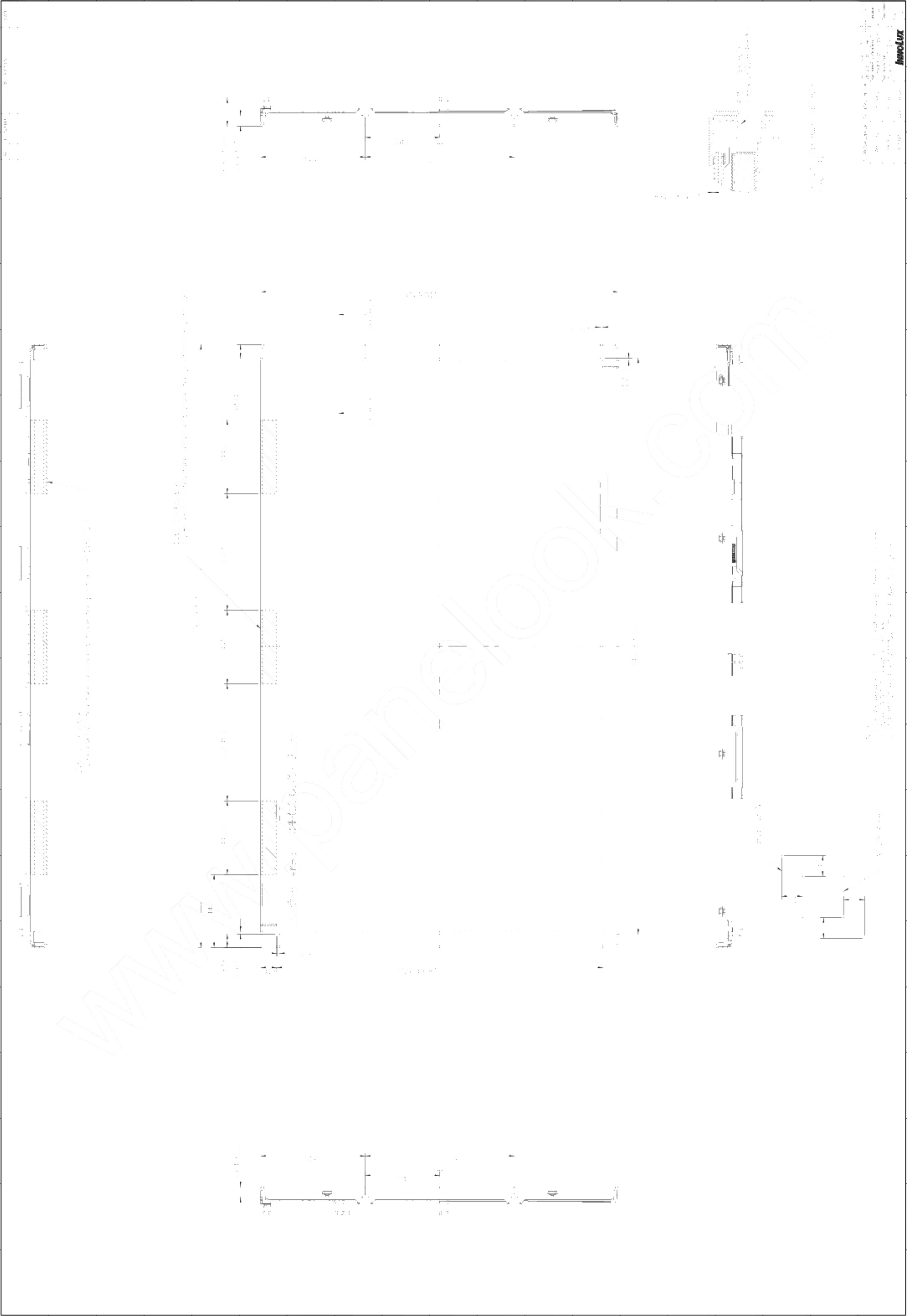

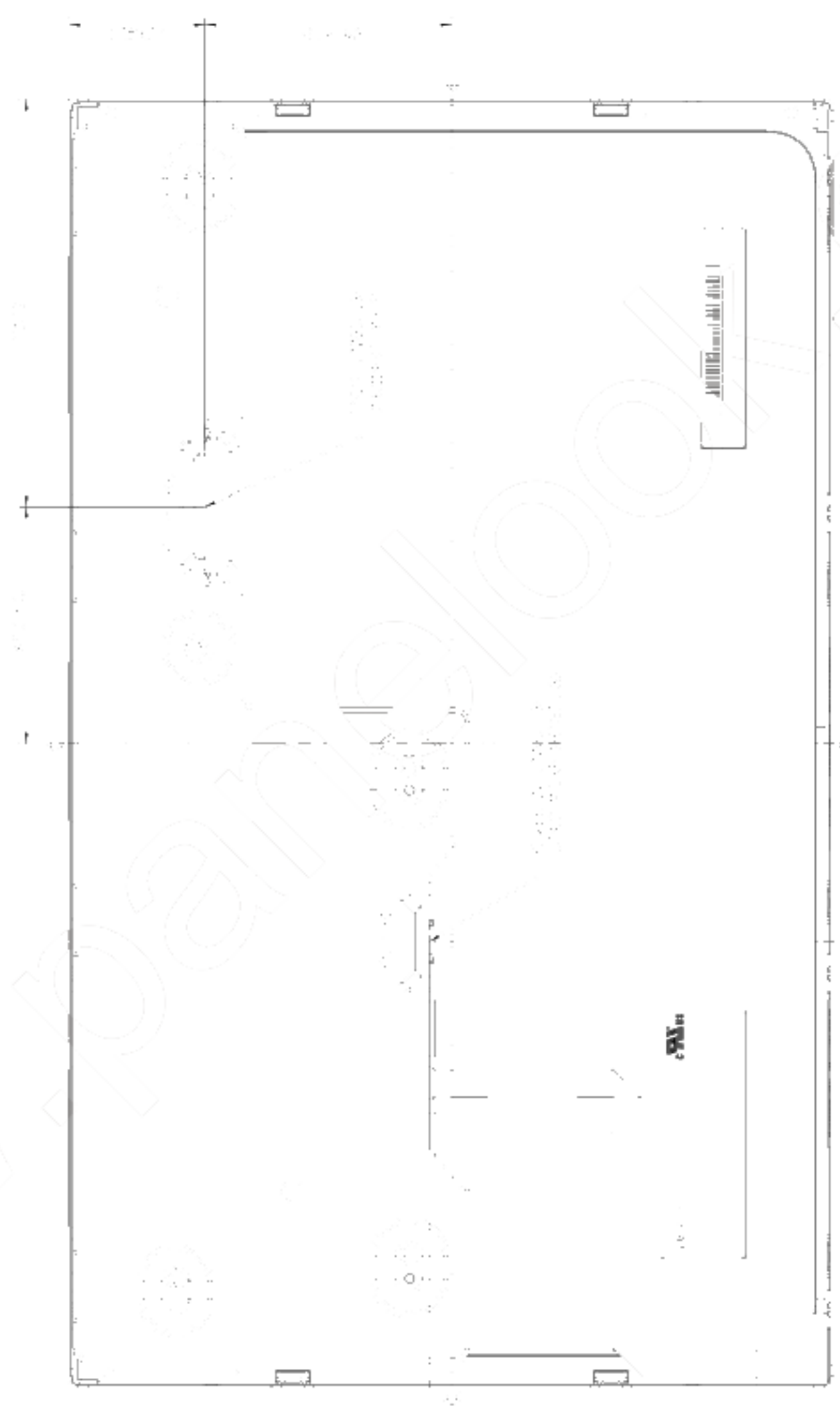

www.panelook.com

www.panelook.com