



Product Specification

G190EG02 V1

AU OPTRONICS CORPORATION

- () Preliminary Specification
- (V) Final Specification

Module	19.0" SXGA Color TFT-LCD
Model Name	G190EG02 V1

<p>Customer</p> <p style="text-align: right;">Date</p> <hr style="border: 0; border-top: 1px solid black; margin: 10px 0;"/> <p>Approved by</p> <hr style="border: 0; border-top: 1px solid black; margin: 10px 0;"/> <p style="margin-top: 20px;">Note: This Specification is subject to change without notice.</p>	<table style="width: 100%; border-collapse: collapse;"> <tr> <td style="text-align: center;">Checked & Approved by</td> <td style="text-align: center;">Date</td> </tr> <tr> <td style="text-align: center; padding: 10px;"><i>Vito Huang</i></td> <td style="text-align: center; padding: 10px;"><u>5/18, 2011</u></td> </tr> <tr> <td colspan="2" style="text-align: center; padding: 10px;">Prepared by</td> </tr> <tr> <td style="text-align: center; padding: 10px;"><i>Linda Lee</i></td> <td style="text-align: center; padding: 10px;"><u>5/18, 2011</u></td> </tr> </table> <p style="text-align: center; margin-top: 20px;">Audio-Video Business Unit / AU Optronics corporation</p>	Checked & Approved by	Date	<i>Vito Huang</i>	<u>5/18, 2011</u>	Prepared by		<i>Linda Lee</i>	<u>5/18, 2011</u>
Checked & Approved by	Date								
<i>Vito Huang</i>	<u>5/18, 2011</u>								
Prepared by									
<i>Linda Lee</i>	<u>5/18, 2011</u>								

AUO confidential for Data Modul use only 2012/05/03



Record of Revision

Version & Date	Page	Old Description	New Description
0.1 2011/03/18	All	Frist Edition for Customer	
1.0 2011/05/18	6	Weight: 1800 g (typ)	Weight: 1750 g (typ)
1.0 2011/05/18	6 & 12	Operating Temperature: Max. +50°C	Operating Temperature: Max. +60°C (as surface temperature)
1.0 2011/05/18	27		Packging Info is added
1.0 2012/05/03	27		LED driving information updated

AUO confidential for Data Modul use only 2012/05/03



Contents

1. Handling Precautions	4
2. General Description	5
2.1 Display Characteristics	6
2.2 Optical Characteristics	7
3. Functional Block Diagram	11
4. Absolute Maximum Ratings	12
4.1 Absolute Ratings of TFT LCD Module.....	12
4.2 Absolute Ratings of Backlight Unit	12
4.3 Absolute Ratings of Environment	12
5. Electrical characteristics	14
5.1 TFT LCD Module	14
5.2 Backlight Unit.....	16
6. Signal Characteristic	17
6.1 Pixel Format Image.....	17
6.2 The Input Data Format	18
6.4 Interface Timing.....	20
6.5 Power ON/OFF Sequence.....	23
7. Connector & Pin Assignment	24
7.1 TFT LCD Module	24
7.2 Backlight Unit.....	25
8. Reliability Test	26
9. Shipping Label and Packaging	27
9.1 Shipping Label	27
9.2 Packaging.....	27
10. Mechanical Characteristic	28



1. Handling Precautions

- 1) Since front polarizer is easily damaged, pay attention not to scratch it.
- 2) Be sure to turn off power supply when inserting or disconnecting from input connector.
- 3) Wipe off water drop immediately. Long contact with water may cause discoloration or spots.
- 4) When the panel surface is soiled, wipe it with absorbent cotton or other soft cloth.
- 5) Since the panel is made of glass, it may break or crack if dropped or bumped on hard surface.
- 6) Since CMOS LSI is used in this module, take care of static electricity and insure human earth when handling.
- 7) Do not open or modify the Module Assembly.
- 8) Do not press the reflector sheet at the back of the module to any directions.
- 9) In case if a Module has to be put back into the packing container slot after once it was taken out from the container, do not press the center of LED light bar edge. Instead, press at the far ends of LED light bar edge softly. Otherwise the TFT Module may be damaged.
- 10) At the insertion or removal of the Signal Interface Connector, be sure not to rotate nor tilt the Interface Connector of the TFT Module.
- 11) After installation of the TFT Module into an enclosure, do not twist or bend the TFT Module even momentary. At designing the enclosure, it should be taken into consideration that no bending/twisting forces are applied to the TFT Module from outside. Otherwise the TFT Module may be damaged.
- 12) Small amount of materials having no flammability grade is used in the LCD module. The LCD module should be supplied by power complied with requirements of Limited Power Source (IEC60950 or UL1950), or be applied exemption.

AUO confidential for Data Model Use only 2012/05/03



2. General Description

G190EG02 V1 is a Color Active Matrix Liquid Crystal Display composed of a TFT-LCD panel, a driver circuit, and a backlight system. The screen format is intended to support the SXGA (1280(H) x 1024(V)) screen and 16.7M colors. All input signals are 2-channel LVDS interface compatible.

AUO confidential for Data Modul use only 2012/05/03



2.1 Display Characteristics

The following items are characteristics summary on the table under 25 °C condition:

Items	Unit	Specifications
Screen Diagonal	[mm]	482.6 (19.0")
Active Area	[mm]	376.32 (H) x 301.06 (V)
Pixels H x V		1280(x3) x 1024
Pixel Pitch	[mm]	0.294 (per one triad) x 0.294
Pixel Arrangement		R.G.B. Vertical Stripe
Display Mode		Normally Black
White Luminance	[cd/m ²]	300 (center, Typ) @ 110mA
Contrast Ratio		2000 : 1 (Typ)
Optical ResponseTime	[msec]	20 ms(Typ, on/off)
Nominal Input Voltage VDD	[Volt]	+5.0 V
Power Consumption	[Watt]	30.6 W
Weight	[Grams]	1750 (TYP)
Physical Size (H x V x D)	[mm]	396 (H) x 324 (V) x 18.4 (D) (Typ)
Electrical Interface		Dual channel LVDS
Surface Treatment		Anti-Glare treatment
Support Color		16.7M colors
Temperature Range Operating Storage (Non-Operating)	[°C] [°C]	0 to +60 -20 to +60
RoHS Compliance		RoHS Compliance

AUO confidential for Data Module use only 2012/05/03



2.2 Optical Characteristics

The optical characteristics are measured under stable conditions at 25°C (Room Temperature):

Item	Unit	Conditions	Min.	Typ.	Max.	Note
Viewing Angle	[degree]	Horizontal (Right) CR = 10 (Left)	75 75	89 89	-	1
		Vertical (Up) CR = 10 (Down)	75 75	89 89	-	
Luminance Uniformity	[%]	9 Points	75	80	-	3
Optical Response Time	[msec]	Rising	-	15	25	4, 6
		Falling	-	5	10	
		Rising + Falling	-	20	35	
Color / Chromaticity Coordinates (CIE)		Red x	0.597	0.647	0.697	4
		Red y	0.290	0.340	0.390	
		Green x	0.277	0.327	0.377	
		Green y	0.551	0.601	0.651	
		Blue x	0.092	0.142	0.192	
		Blue y	0.017	0.067	0.117	
		White x	0.263	0.313	0.363	
White y	0.279	0.329	0.379			
White Luminance (At LED= 110mA)	[cd/m ²]		240	300	-	4
Contrast Ratio			1000	2000	-	4
Cross Talk (At 60Hz)	[%]		-	-	1.5	5
Flicker	[dB]		-	-	-20	7

Note 1: Definition of viewing angle, measured by ELDIM (EZContrast 88)

Viewing angle is the measurement of contrast ratio ≥ 10 , or ≥ 5 , at the screen center, over a 180° horizontal and 180° vertical range (off-normal viewing angles). The 180° viewing angle range is broken down as follows; 90° (θ) horizontal left and right and 90° (Φ) vertical, high (up) and low (down). The measurement direction is typically perpendicular to the display surface with the screen rotated about its center to develop the desired measurement viewing angle.

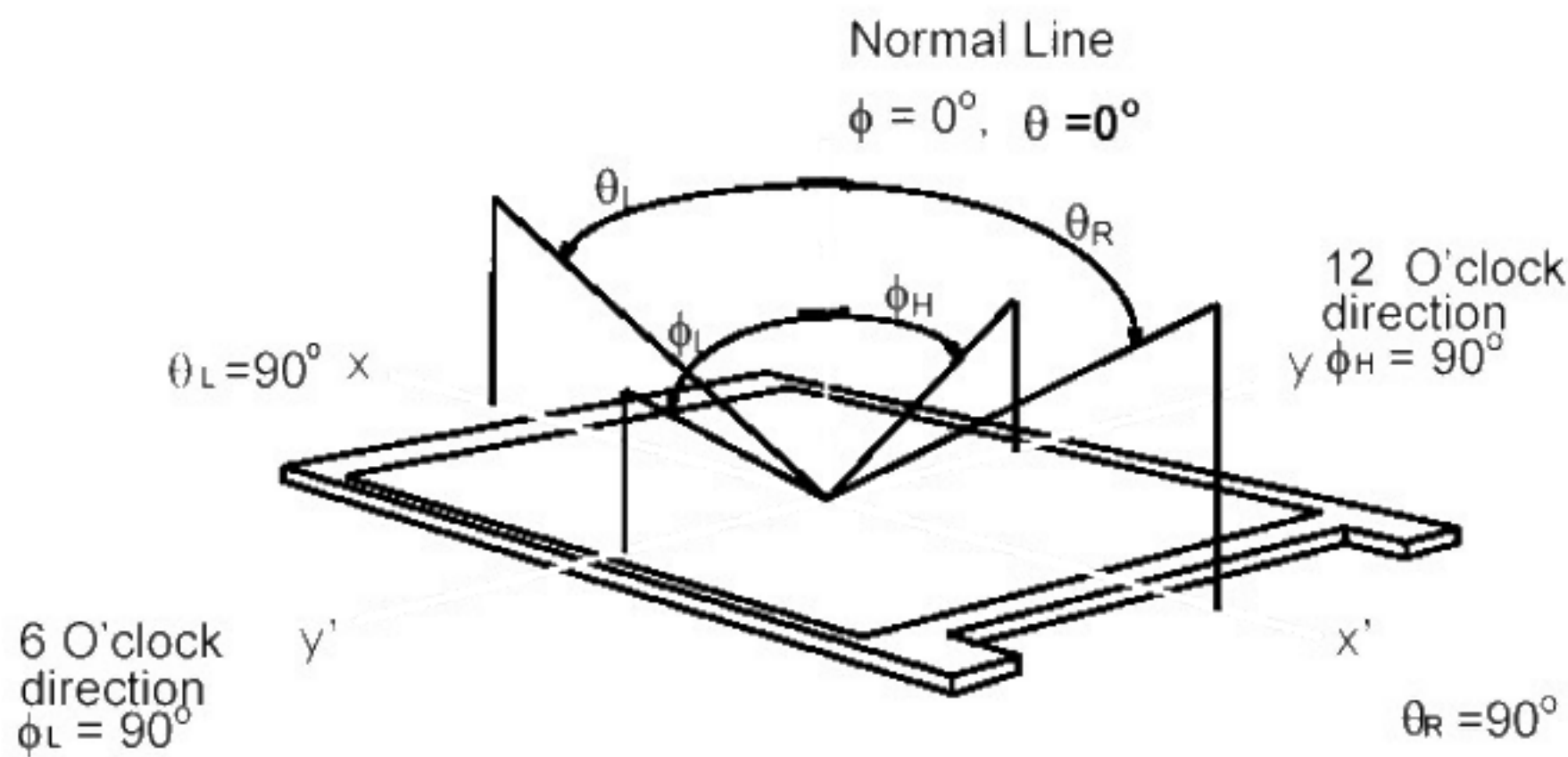

12/05/03

Note 2: 9 points position

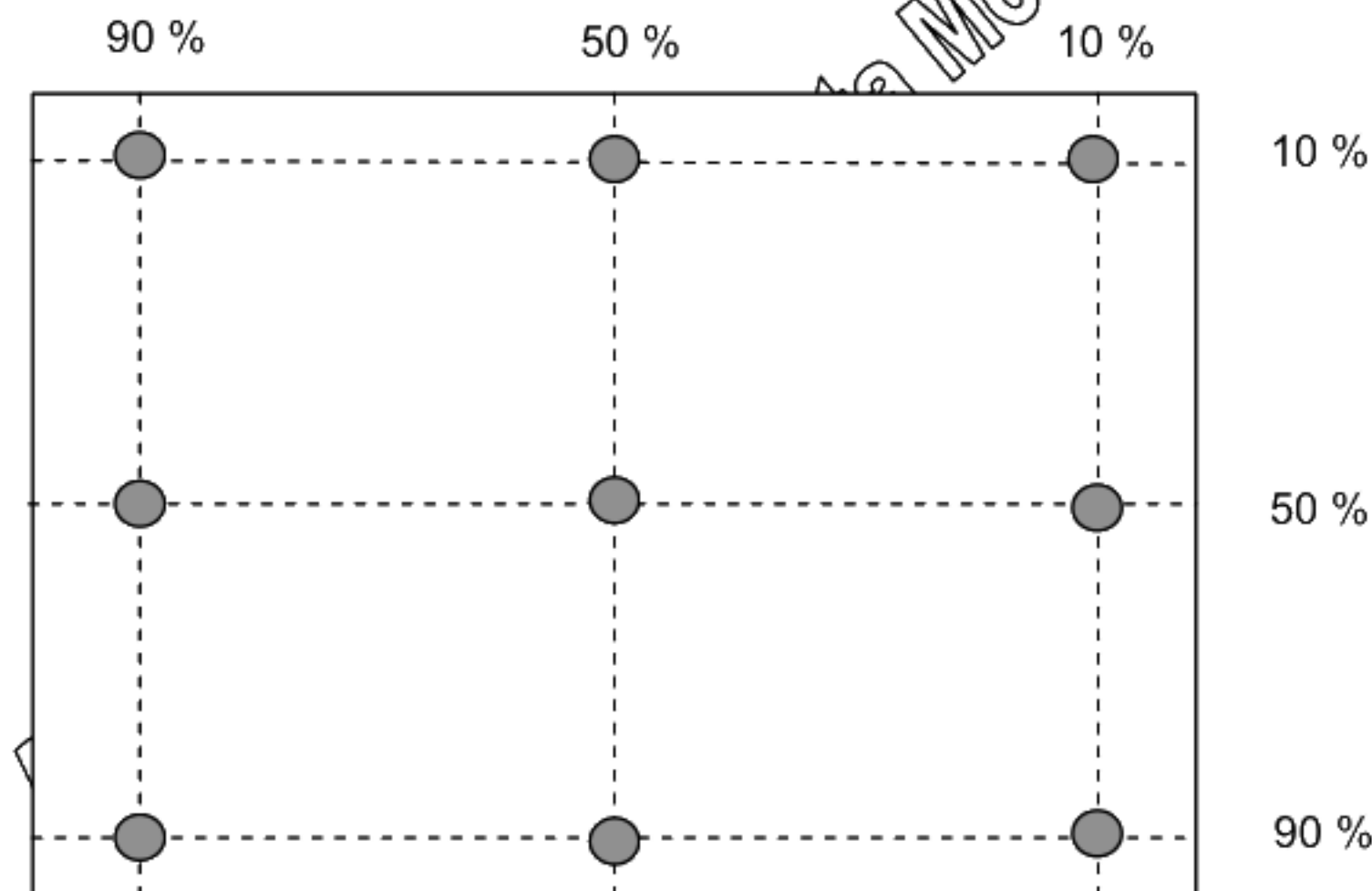

Note 3: The luminance uniformity of 9 points is defined by dividing the maximum luminance values by the minimum test point luminance. And measured by TOPCON SR-3

$$\delta_{w9} = \frac{\text{Minimum Luminance of 9 points}}{\text{Maximum Luminance of 9 points}}$$

Note 4: Measurement method

The LCD module should be stabilized at given temperature for 30 minutes to avoid abrupt temperature change during measuring. In order to stabilize the luminance, the measurement should be executed after lighting Backlight for 30 minutes in a stable, windless and dark room.

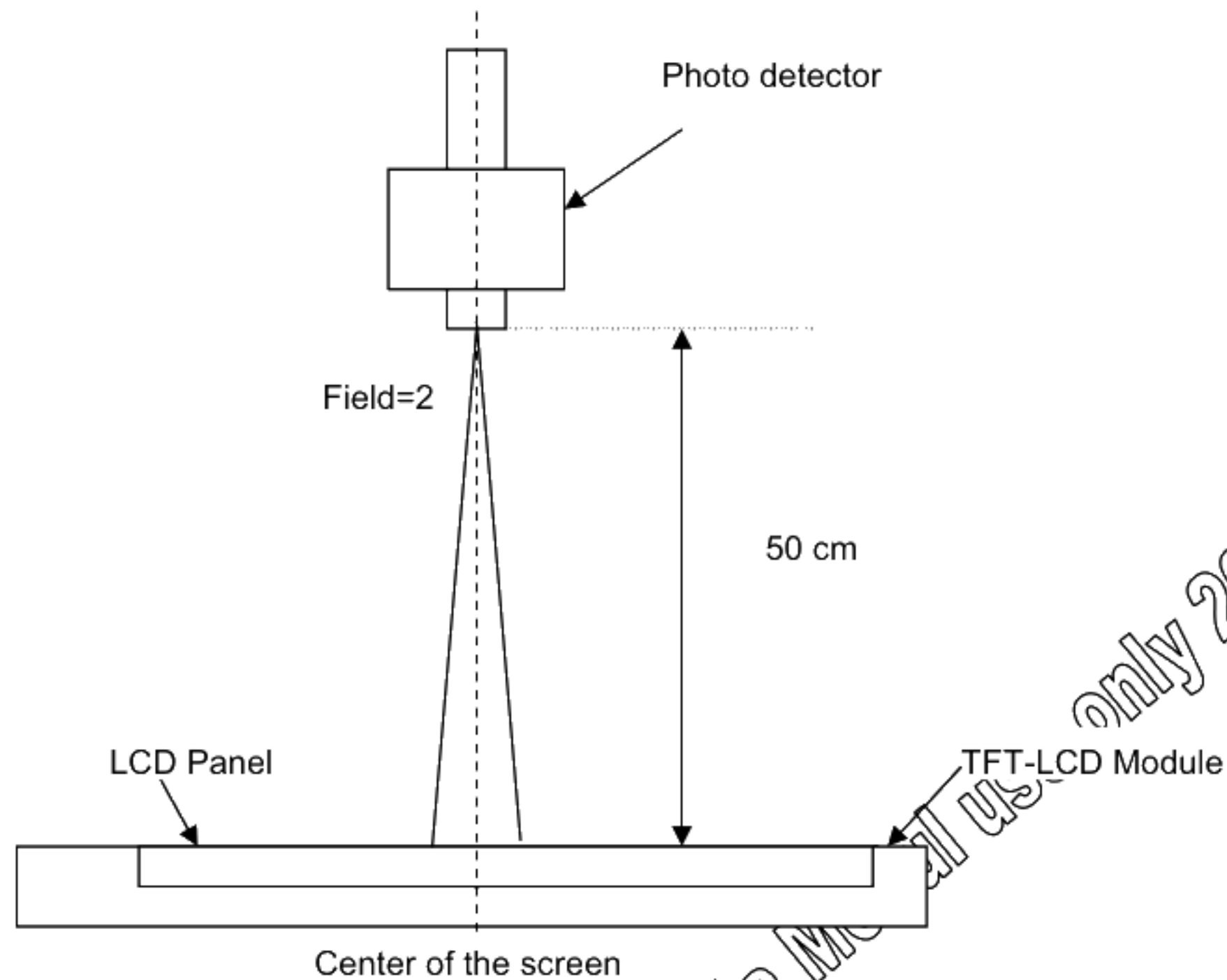

Note 5: Definition of Cross Talk (CT) and measured by TOPCON SR-3

$$CT = |Y_B - Y_A| / Y_A \times 100 (\%)$$

Where

Y_A = Luminance of measured location without gray level 0 pattern (cd/m²)

Y_B = Luminance of measured location with gray level 0 pattern (cd/m²)

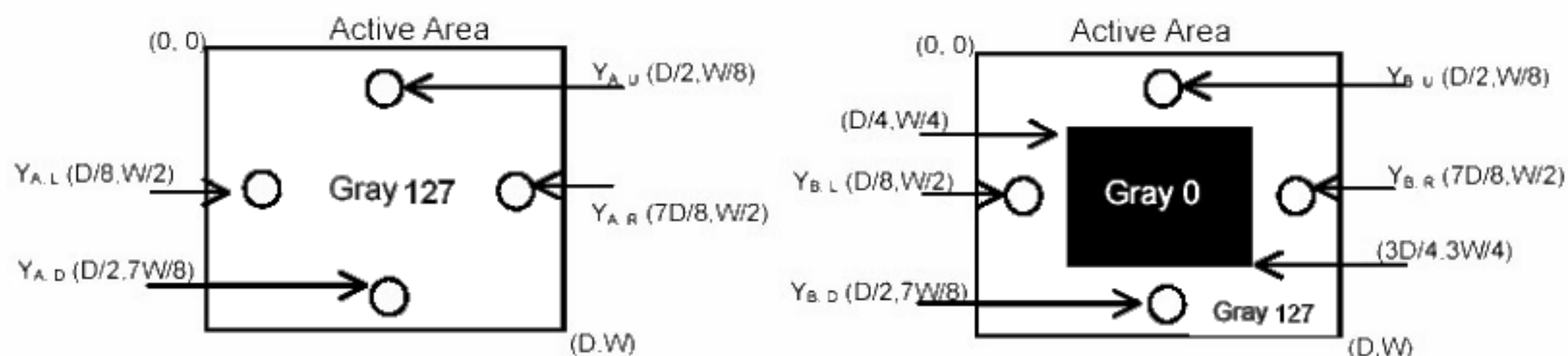

Note 6: Definition of response time, measured by WESTAR TRD-100A

The output signals of photo detector are measured when the input signals are changed from "Full Black" to "Full White" (rising time), and from "Full White" to "Full Black" (falling time), respectively. The response time is interval between the 10% and 90% of amplitudes. Please refer to the figure as below.

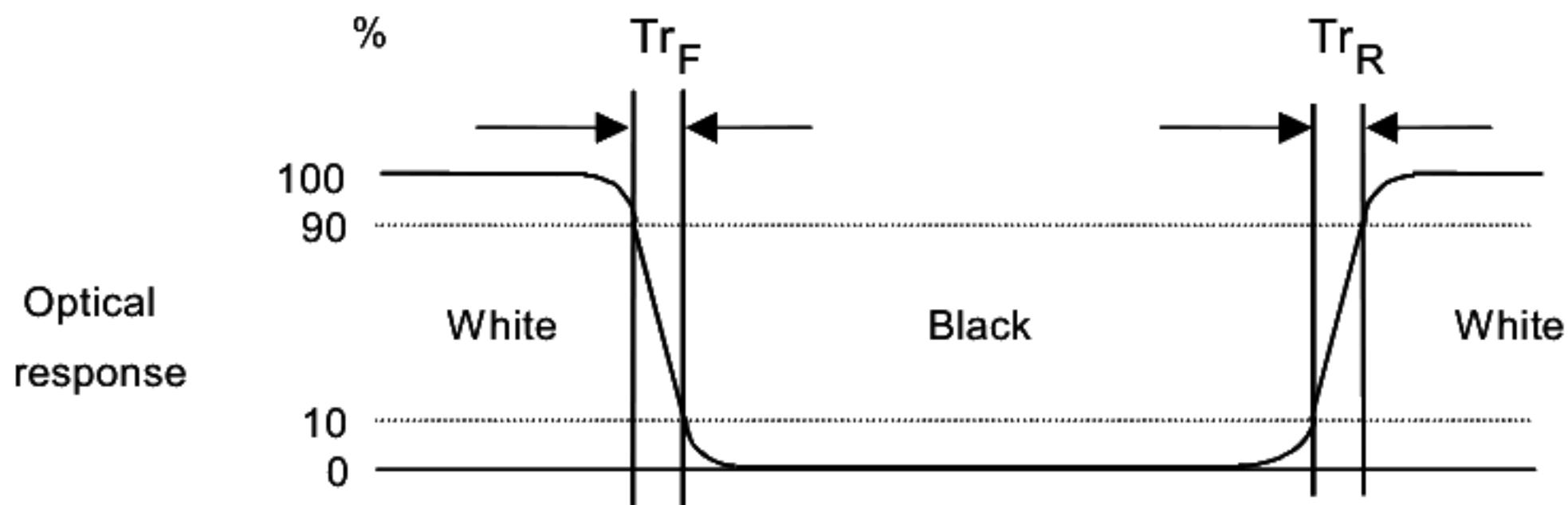

Note 7: Subchecker Pattern

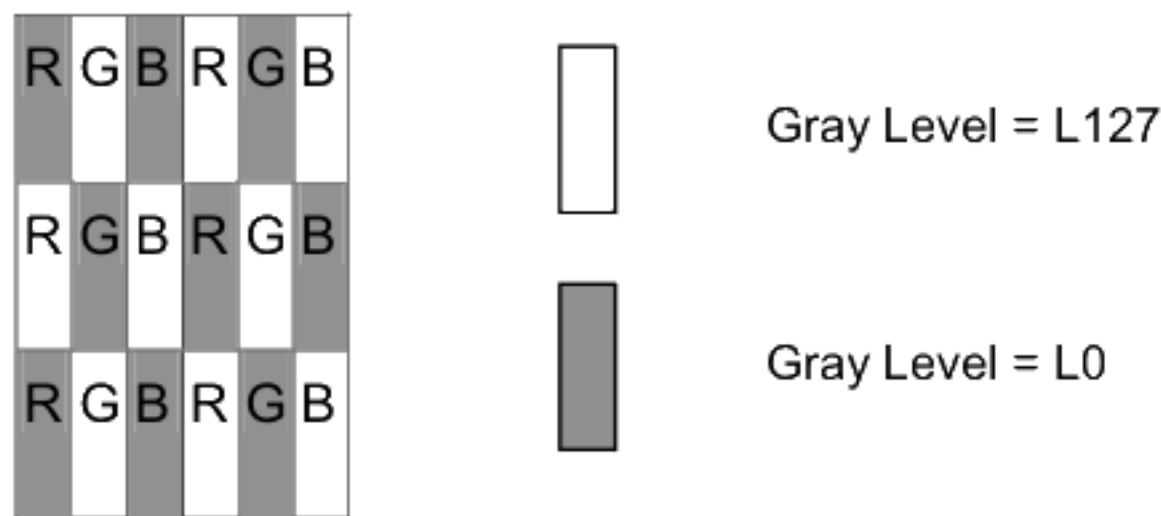

Method: Record dBV & DC value with (WESTAR TRD-100)

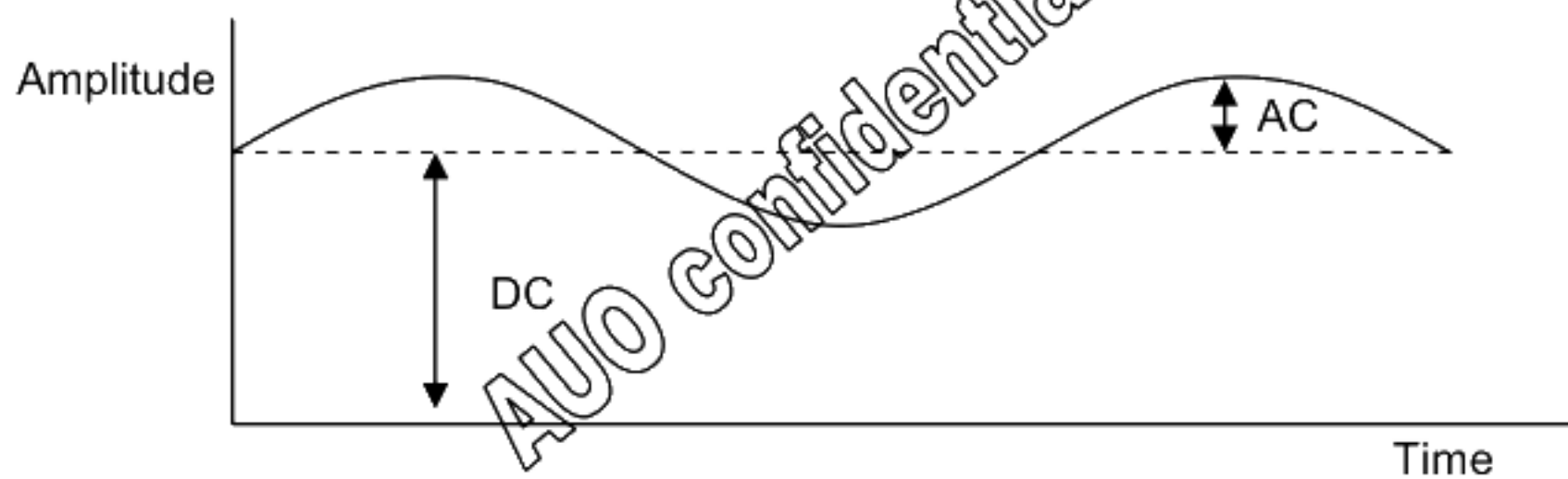

$$\text{Flicker (dB)} = 20 \log \frac{\text{AC Level(at 30 Hz)}}{\text{DC Level}}$$

3. Functional Block Diagram

The following diagram shows the functional block of the 19.0 inches Color TFT-LCD Module:

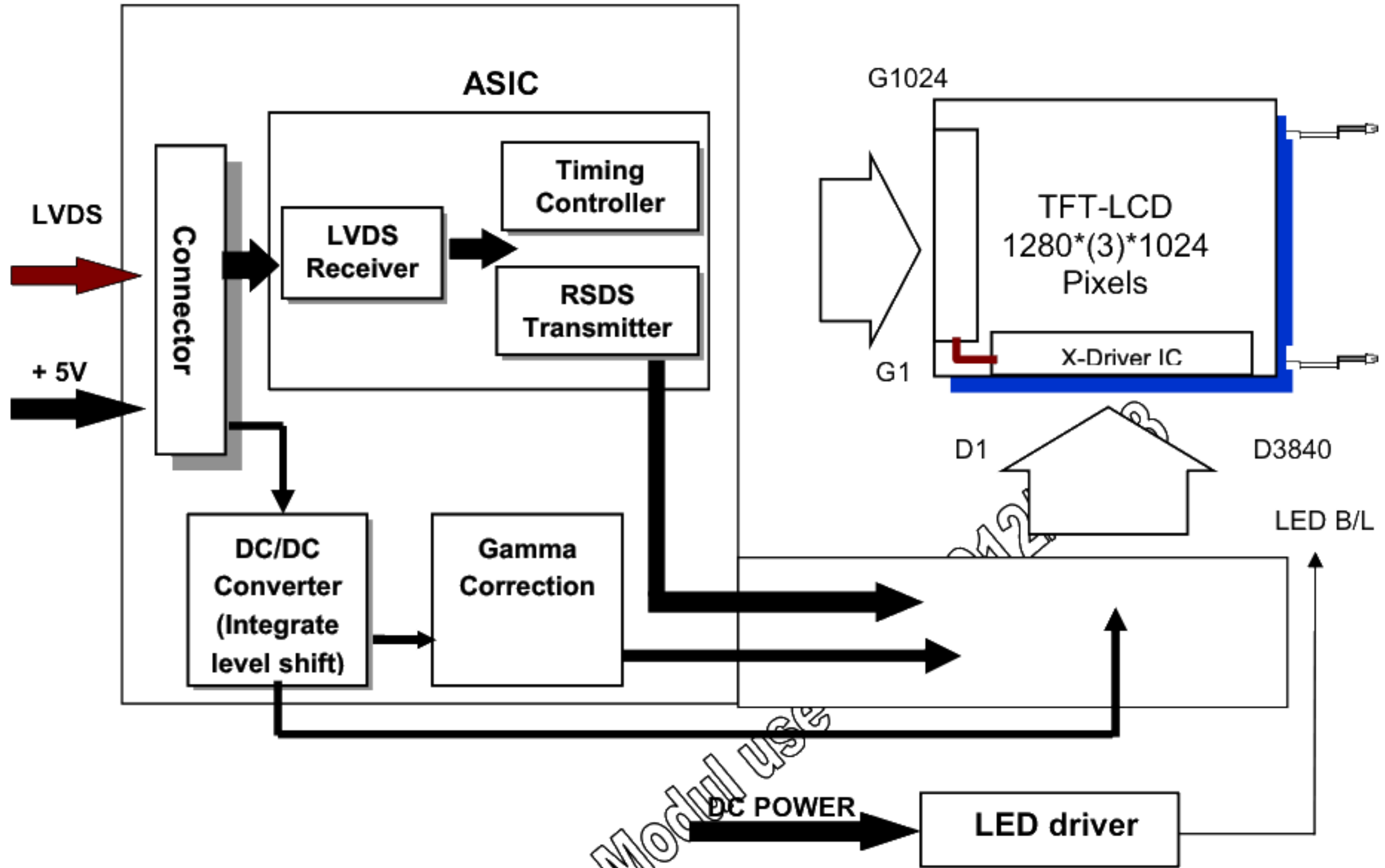

I/F PCB Interface:

FI-XB30SSL-HF15 / MSBKT2407P30HB

Mating Type:

- FI-X30HL (Locked Type)
- FI-X30H (Unlocked Type)

AUO Confidential for Data Module use



4. Absolute Maximum Ratings

Absolute maximum ratings of the module are as following:

4.1 Absolute Ratings of TFT LCD Module

Item	Symbol	Min.	Max.	Unit	Conditions
Logic/LCD Drive Voltage	VDD	-0.3	+5.5	[Volt]	Note 1, 2

4.2 Absolute Ratings of Backlight Unit

Item	Symbol	Min.	Max.	Unit	Conditions
LED Power Current	Iled	-	1.7	[A] rms	Note 1, 2

4.3 Absolute Ratings of Environment

Item	Symbol	Min.	Max.	Unit	Conditions
Operating Temperature	TOP	0	+60	[°C]	Note 3 & 4
Operation Humidity	HOP	5	90	[%RH]	
Storage Temperature	TST		+60	[°C]	
Storage Humidity	HST		90	[%RH]	

AUO confidential for Data Module Use Only 2012/03/03

Note 1: With in $T_a = 25^\circ\text{C}$

Note 2: Permanent damage to the device may occur if exceed maximum values

Note 3: For quality performance, please refer to AUO IIS (Incoming Inspection Standard).

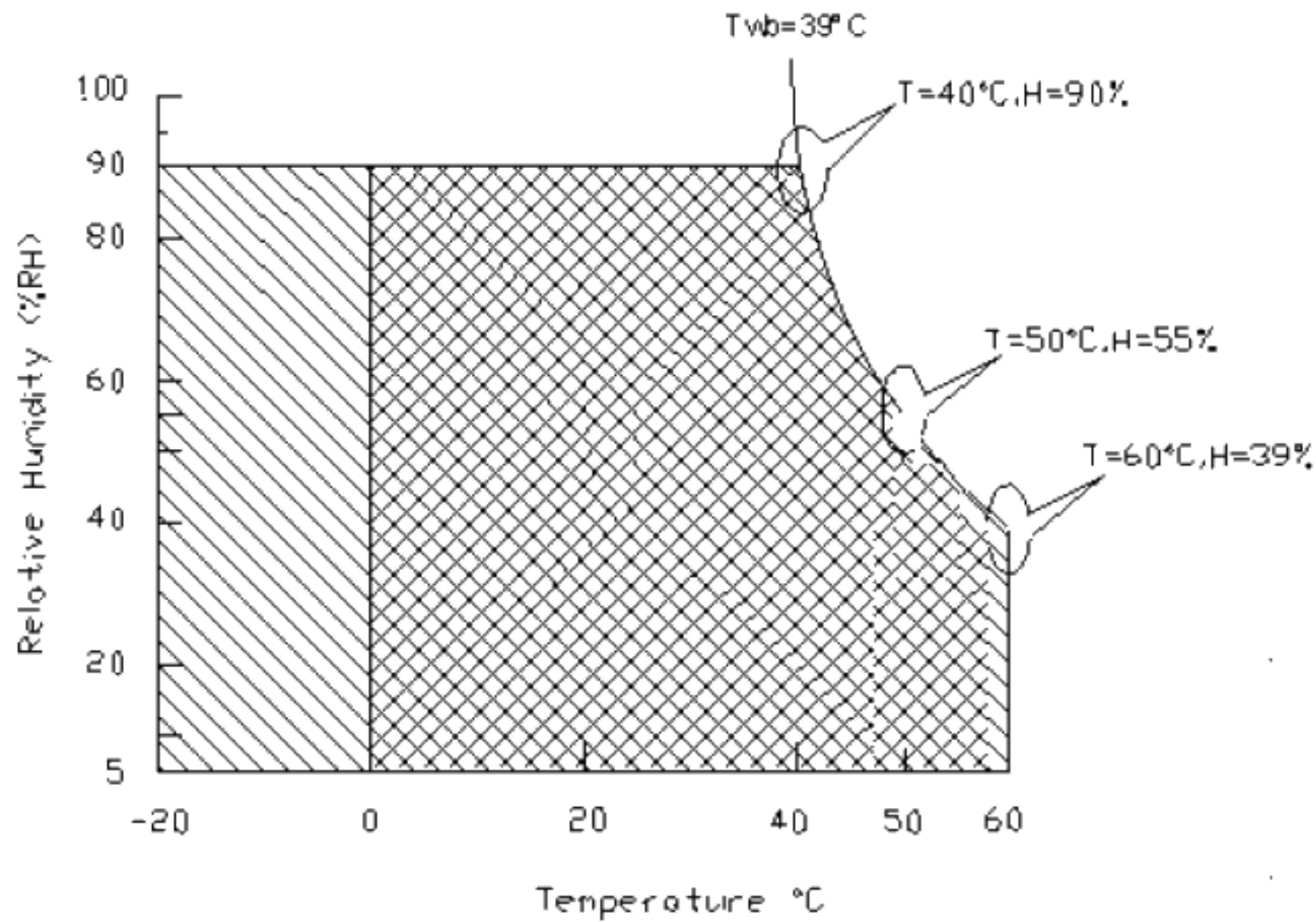

2/103

Operating Range



Storage Range



Note 4: Operation Temperature + 60°C is defined as panel surface temperature.

AUO confidential for Data Module Use

5. Electrical characteristics

5.1 TFT LCD Module

5.1.1 Power Specification

Input power specifications are as follows:

Symble	Parameter	Min.	Typ.	Max.	Unit	Condition
VCC	Logic/LCD Drive Voltage	4.5	5.0	5.5	[Volt]	±10%
ICC	Input Current	-	0.94	1.1	[A]	Vin=5V , All Black Pattern, at 60Hz
IRush	Inrush Current	-	2.1	2.5	[A]	Note 2
PCC	VCCPower	-	4.7	5.5	[Watt]	Vin=5V , All Black Pattern, at 60Hz
VCCrp	Allowable Logic/LCD Drive Ripple Voltage	-	-	300	[mV] p-p	With panel loading

Note 1: The H-Stripe pattern is defined as below :

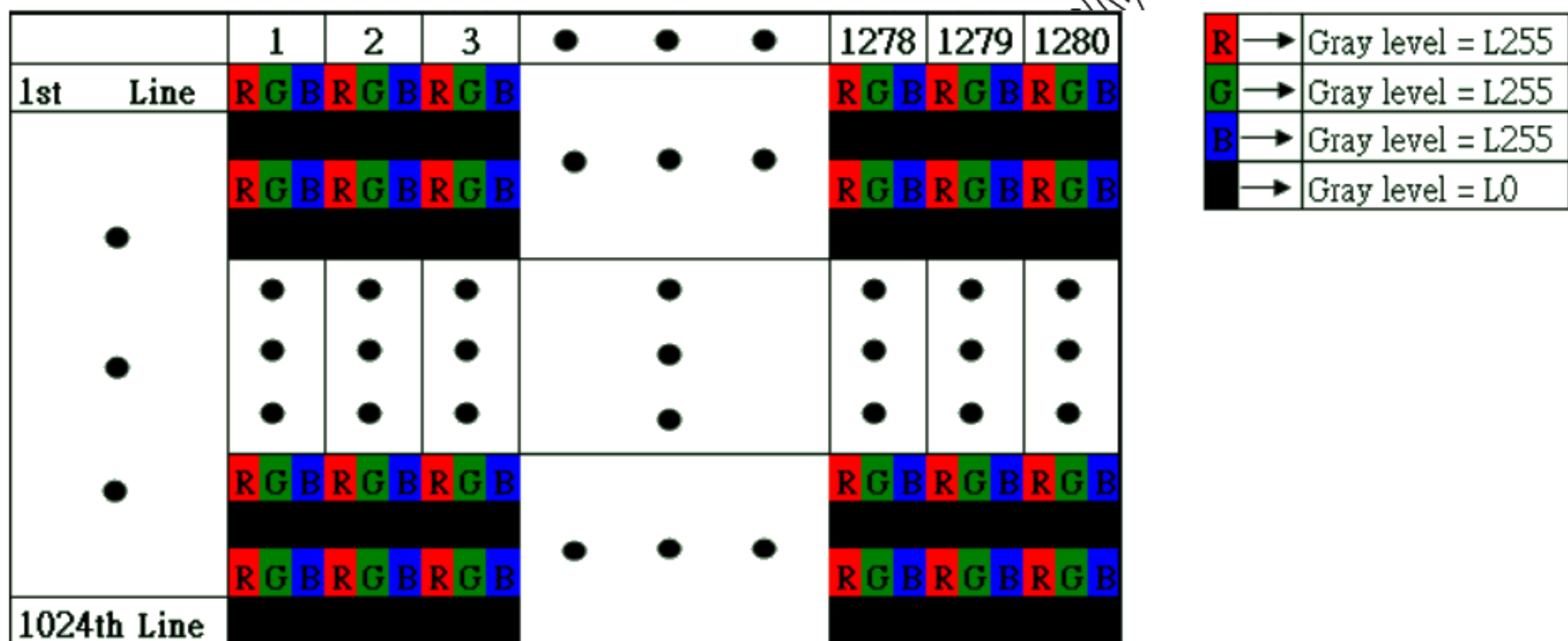

Note 2: Measurement conditions:

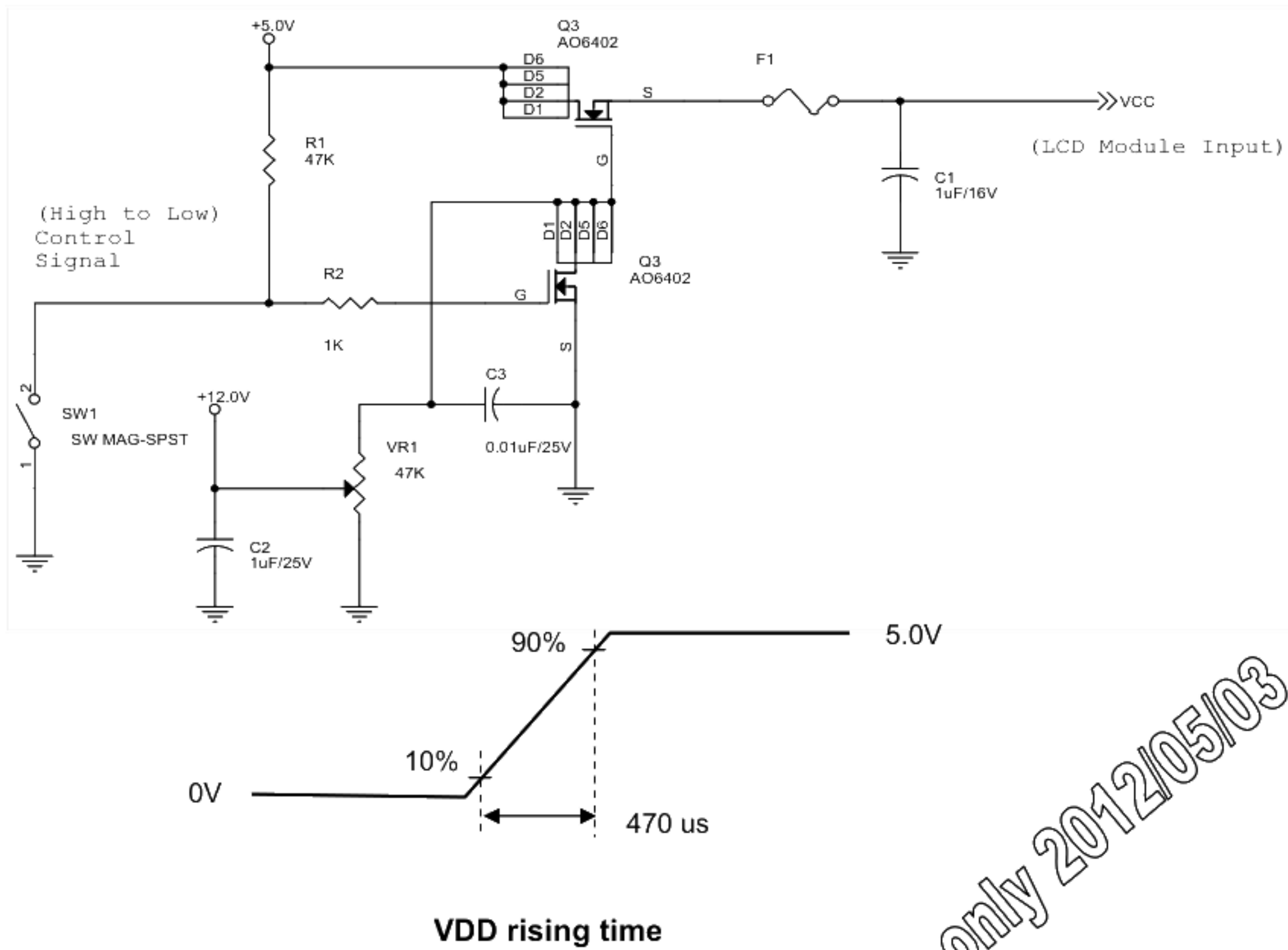

AUO confidential for Data Modul use only 2012/05/03

5.2 Backlight Unit

Following characteristics are measured under a stable condition at 25 °C (Room Temperature):

Symbol	Parameter	Min.	Typ.	Max.	Unit	Remark
VCC	Input Voltage	10.8	12	13.2	[Volt]	
I _{VCC}	Input Current		1.87	2.1	[A]	100% PWM Duty
P _{VCC}	Power Consumption		22.4	25.1	[Watt]	100% PWM Duty
I _{rush LED}	Inrush Current	-	2.1	2.5	[A]	at rising time=470us
F _{PWM}	Dimming Frequency		0.2	20	[kHz]	
	Swing Voltage	3.0	3.3	5.5	V	
	Dimming Duty Cycle	10	-	100	%	
I _F	LED Forward Current		110		mA	Ta = 25°C
V _F	LED Forward Voltage	-	-	-	Volt	
		-	3.4	3.8	Volt	I _F = 110mA, Ta = 25°C
		-	-	-		
P _{LED}	LED Power Consumption	-	20.2	22.6	Watt	I _F = 110 mA, Ta = 25°C
LED Lifetime		50,000			Hrs	I _F = 110mA, Ta = 25°C

Note 1: Ta means ambient temperature of TFT-LCD module.

Note 2: VCC, I_{VCC}, P_{VCC}, I_{rush LED} are defined for LED B/L.(100% duty of PWM dimming)

Note 3: I_F, V_F, P_{LED} are defined for LED Light Bar.

Note 4: If G190EG02 V1 module is driven by high current or at high ambient temperature & humidity condition. The operating life will be reduced.

Note 5: LED life means brightness goes down to 50% initial brightness.

AUO confidential for Data Modul use only 2012/05/03

6. Signal Characteristic

6.1 Pixel Format Image

Following figure shows the relationship of the input signals and LCD pixel format.

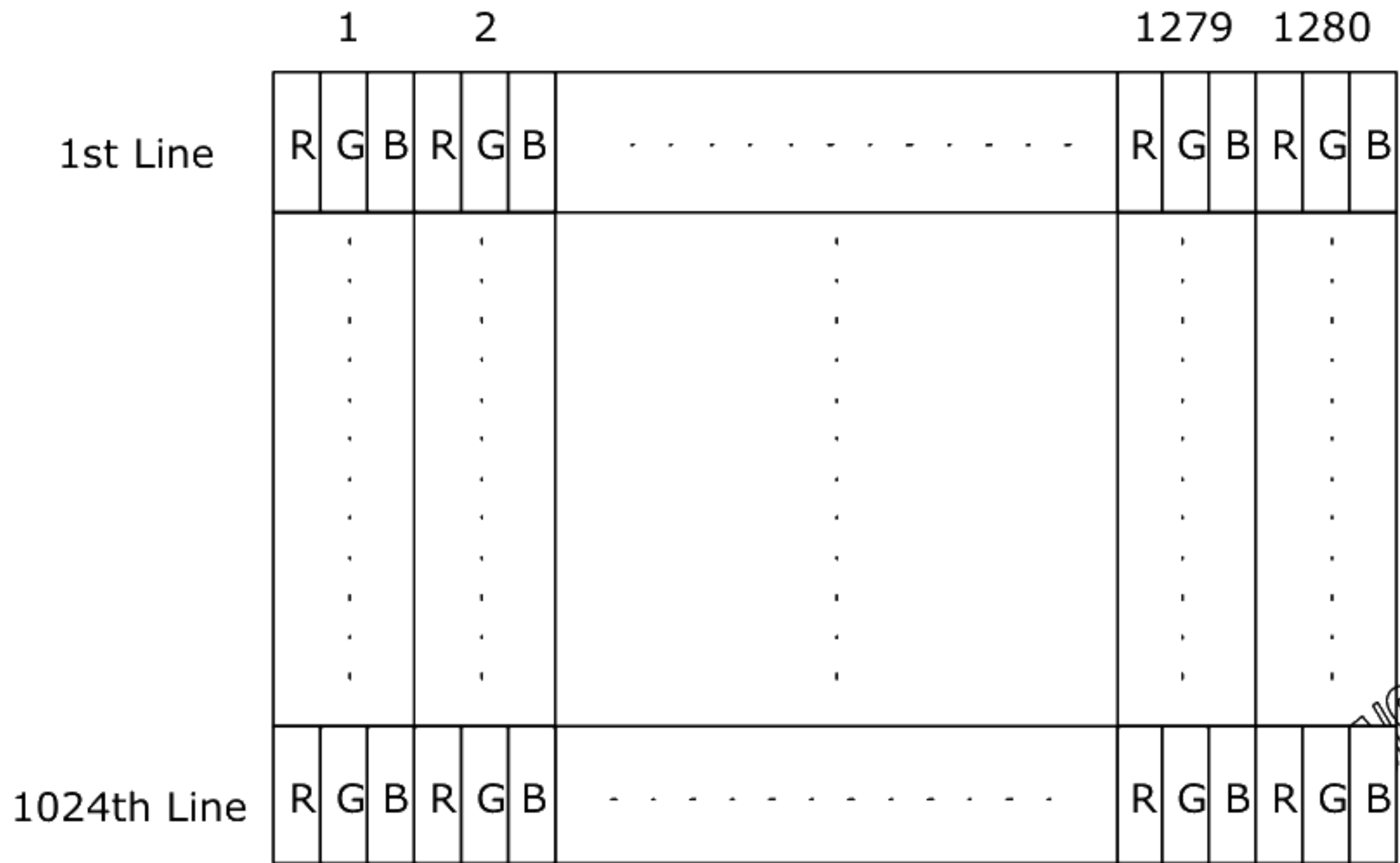

AUO confidential for Data Modul use only 20103

6.2 The Input Data Format

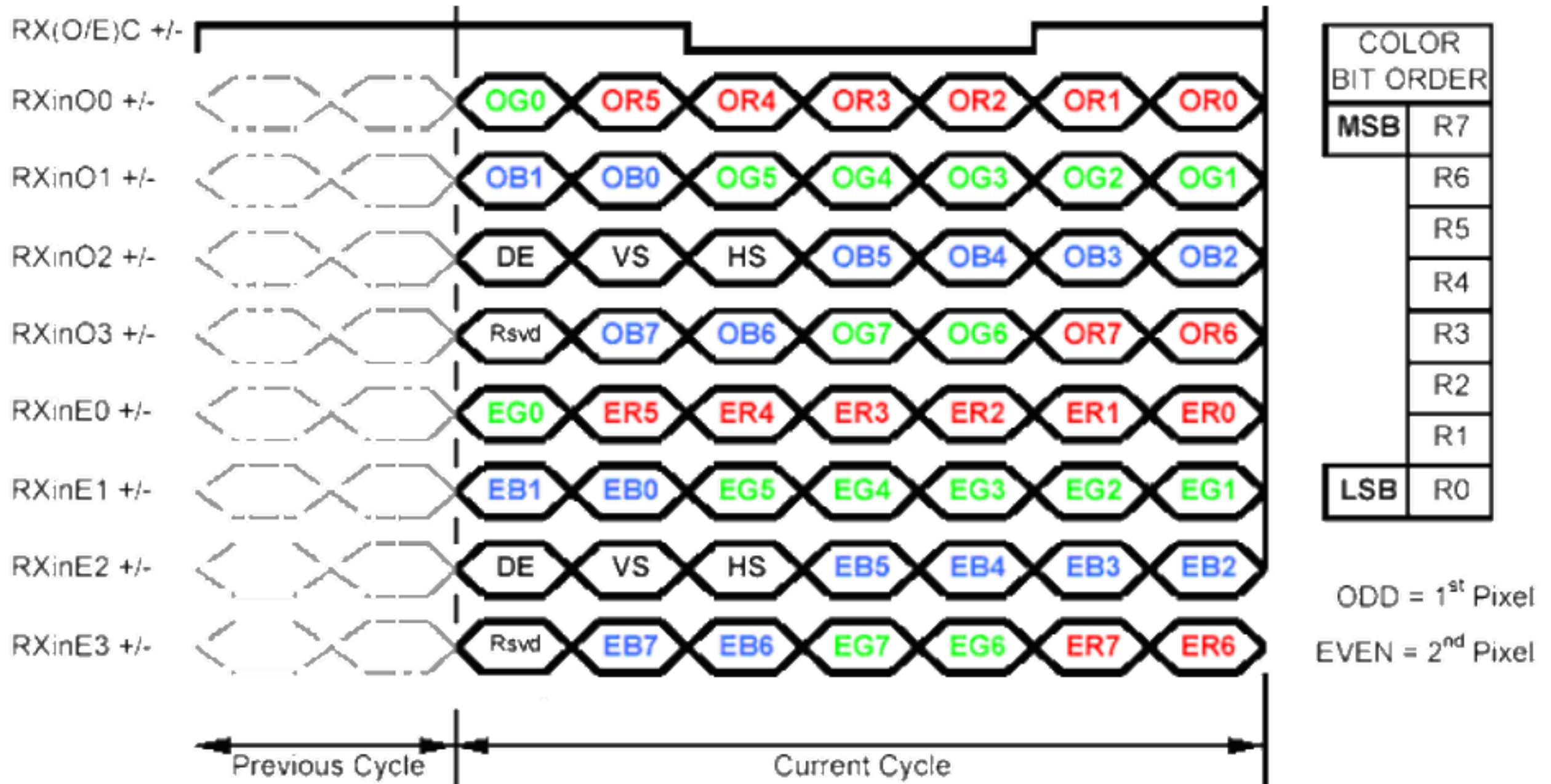

Note1: Normally DE mode only. VS and HS on EVEN channel are not used.

Note2: Please follow VESA.

Note3: 8-bit in

AUO confidential for Data Modul use only 2012/05/10



6.3 Signal Description

The module using a pair of LVDS receiver SN75LVDS82(Texas Instruments) or compatible. LVDS is a differential signal technology for LCD interface and high speed data transfer device. Transmitter shall be SN75LVDS83(negative edge sampling) or compatible. The first LVDS port(RxOxxx) transmits odd pixels while the second LVDS port(RxExxx) transmits even pixels.

PIN #	SIGNAL NAME	DESCRIPTION
1	RxOIN0-	Negative LVDS differential data input (Odd data)
2	RxOIN0+	Positive LVDS differential data input (Odd data)
3	RxOIN1-	Negative LVDS differential data input (Odd data)
4	RxOIN1+	Positive LVDS differential data input (Odd data)
5	RxOIN2-	Negative LVDS differential data input (Odd data, H-Sync,V-Sync,DSPTMG)
6	RxOIN2+	Positive LVDS differential data input (Odd data, H-Sync,V-Sync,DSPTMG)
7	VSS	Power Ground
8	RxOCLKIN-	Negative LVDS differential clock input (Odd clock)
9	RxOCLKIN+	Positive LVDS differential clock input (Odd clock)
10	RxOIN3-	Negative LVDS differential data input (Odd data)
11	RxOIN3+	Positive LVDS differential data input (Odd data)
12	RxEIN0-	Negative LVDS differential data input (Even data)
13	RxEIN0+	Positive LVDS differential data input (Even data)
14	VSS	Power Ground
15	RxEIN1-	Negative LVDS differential data input (Even data)
16	RxEIN1+	Positive LVDS differential data input (Even data)
17	VSS	Power Ground
18	RxEIN2-	Negative LVDS differential data input (Even data)
19	RxEIN2+	Positive LVDS differential data input (Even data)
20	RxECLKIN-	Negative LVDS differential clock input (Even clock)
21	RxECLKIN+	Positive LVDS differential clock input (Even clock)
22	RxEIN3-	Negative LVDS differential data input (Even data)
23	RxEIN3+	Positive LVDS differential data input (Even data)
24	VSS	Power Ground
25	VSS	Power Ground
26	NC	Do not connect (for AUO test)
27	VSS	Power Ground
28	VCC	+5.0V Power Supply
29	VCC	+5.0V Power Supply
30	VCC	+5.0V Power Supply

AUO Confidential for Data Module use only 2012/05/03

Note1: Start from left side

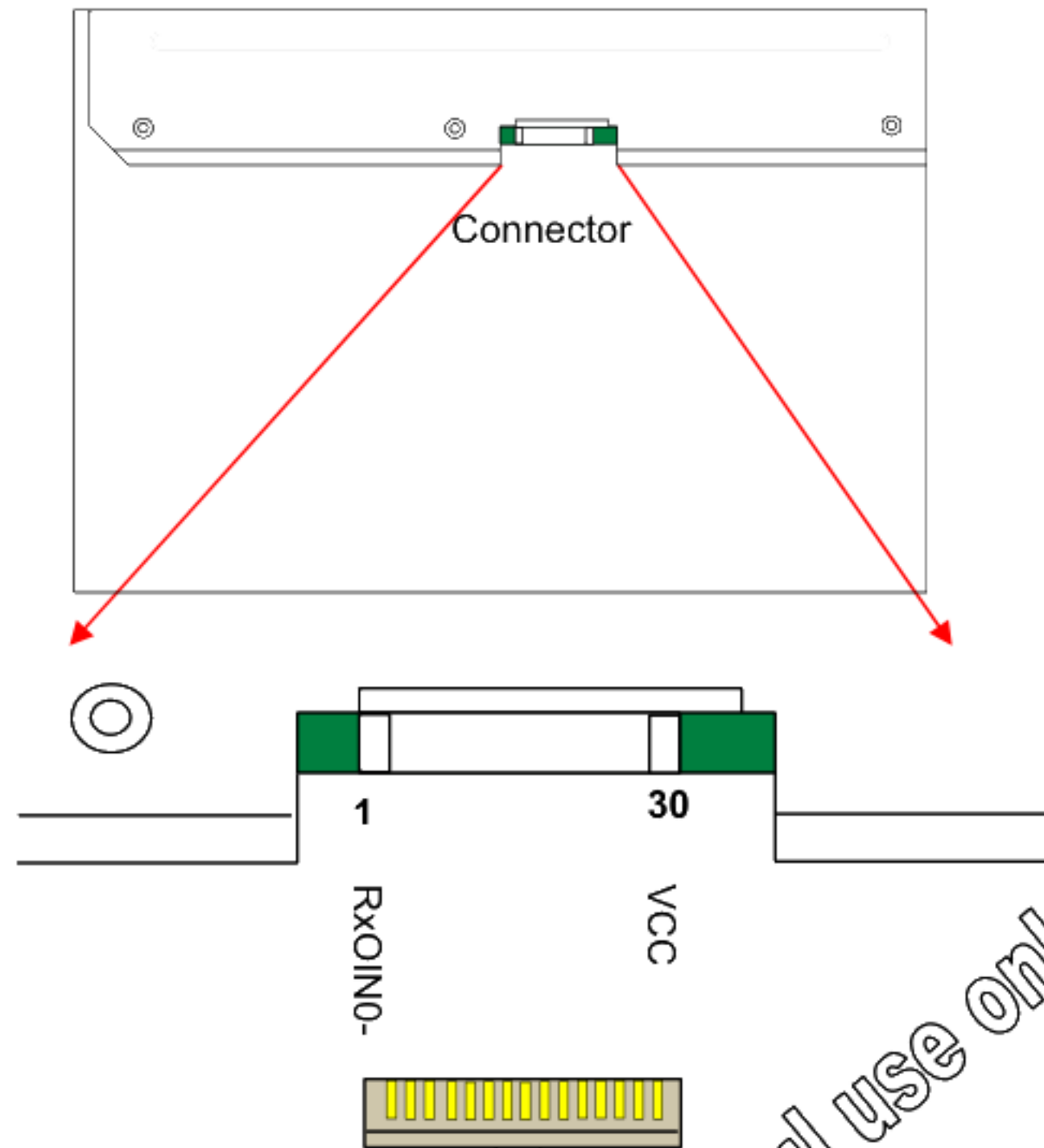

Note2: Input signals of odd and even clock shall be the same timing.

Note3: Please follow VESA.

6.4 Interface Timing

6.4.1 Timing Characteristics

Signal	Item	Symbol	Min	Typ	Max	Unit
Vertical Section	Period	T_v	1032	1066	1150	Th
	Active	$T_{disp(v)}$	1024	1024	1024	Th
	Blanking	$T_{bp(v)}+T_{fp(v)}+PW_{vs}$	8	42	126	Th



Product Specification

G190EG02 V1

AU OPTRONICS CORPORATION

Horizontal Section	Period	Th	780	844	2047	Tclk
	Active	Tdisp(h)	640	640	640	Tclk
	Blanking	Tbp(h)+Tfp(h)+PWhs	140	204	-	Tclk
Clock	Period	Tclk	22.2	18.52	14.81	ns
	Frequency	Freq.	45	54	67.5	MHz
Frame Rate	Frequency	1/Tv	50	60	75	Hz

Note : DE mode only

AUO confidential for Data Modul use only 2012/05/03

6.4.2 Timing Diagram

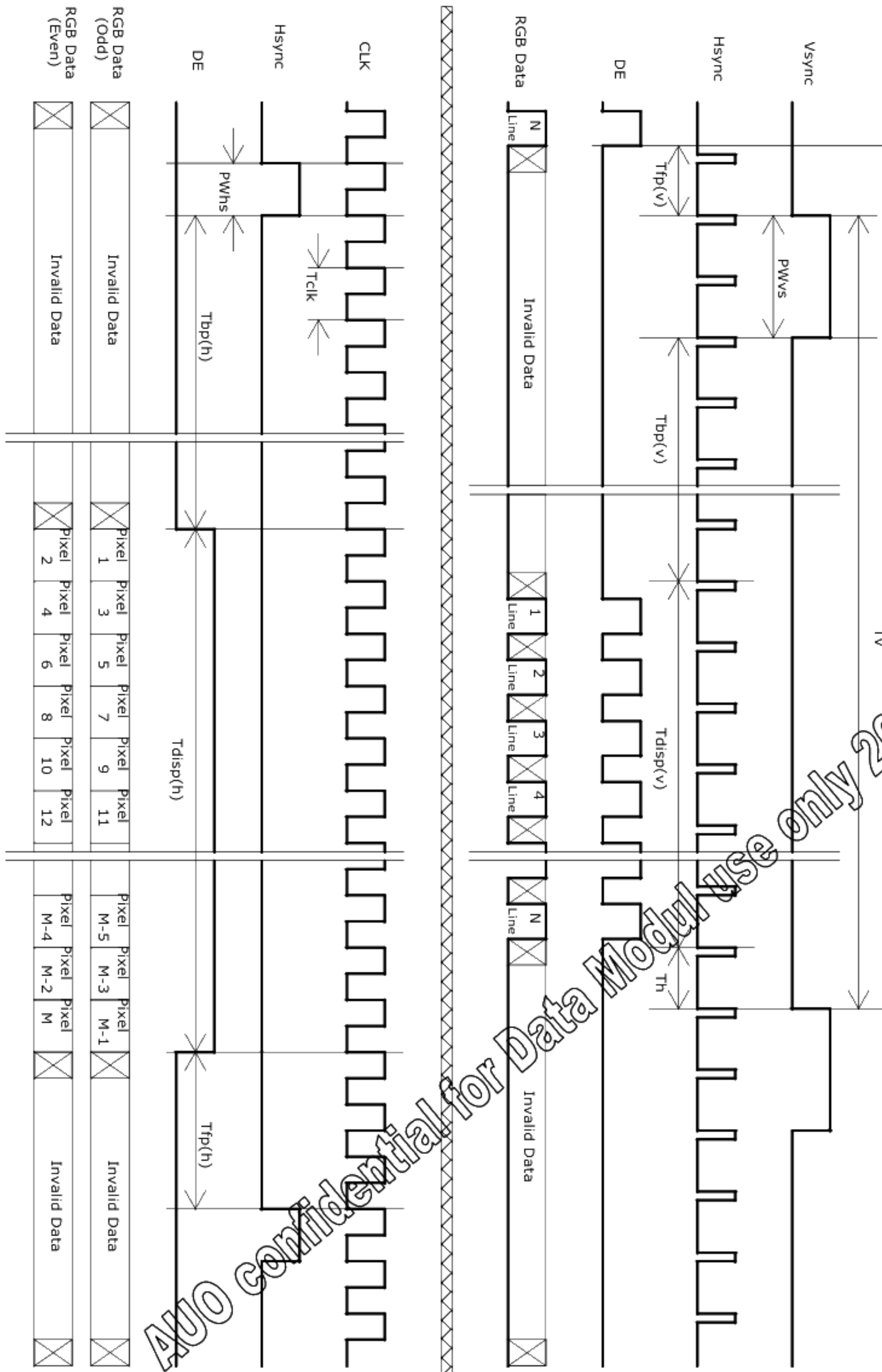

6.5 Power ON/OFF Sequence

VDD power and LED on/off sequence is as follows. Interface signals are also shown in the chart. Signals from any system shall be Hi-Z state or low level when VDD is off.

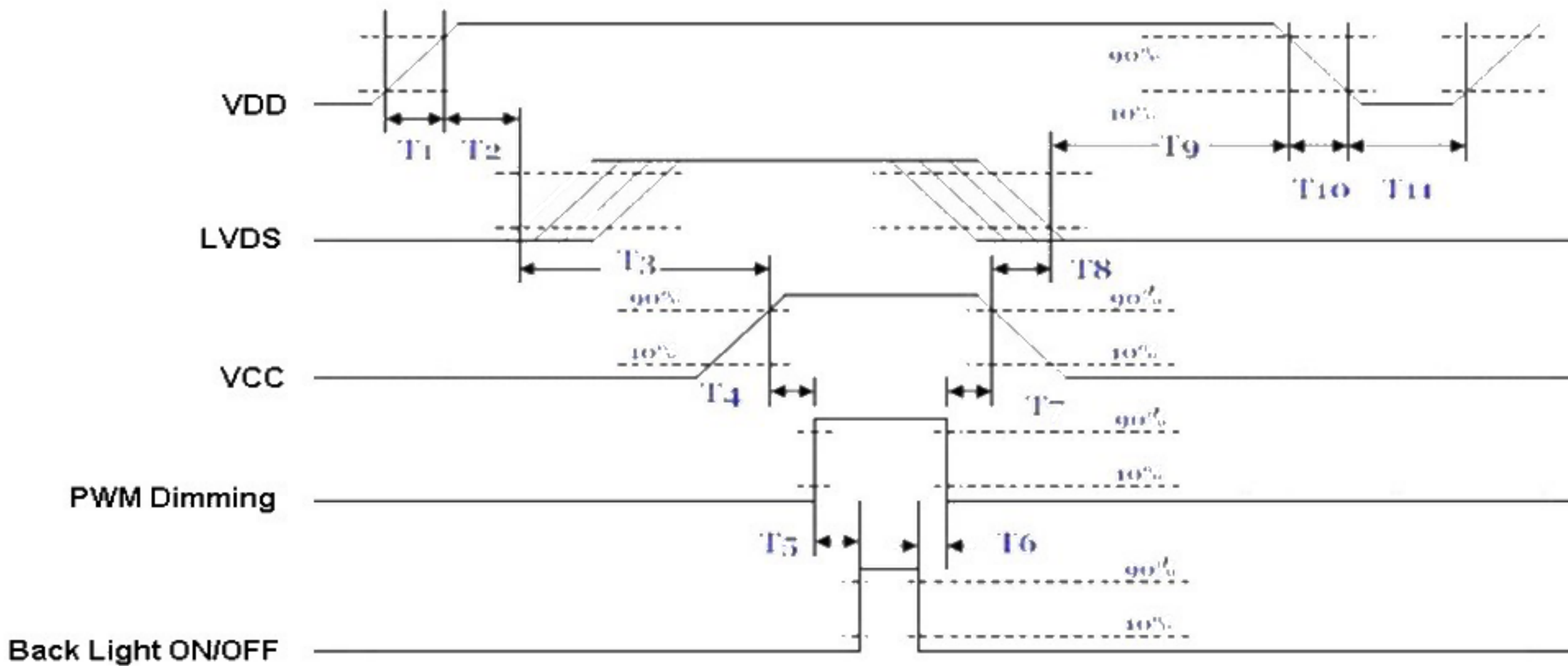

Parameter	Value			Units
	Min.	Typ.	Max.	
T1	0.5	-	10	[ms]
T2	30	40	50	[ms]
T3	175	-	-	[ms]
T4	10	-	-	[ms]
T5	10	-	-	[ms]
T6	0	-	-	[ms]
T7	10	-	-	[ms]
T8	100	-	-	[ms]
T9	0	16	50	[ms]
T10	-	-	10	[ms]
T11	1000	-	-	[ms]

Power Sequence Timing

AUO confidential for Data M...

only 2012/05/03



7. Connector & Pin Assignment

Physical interface is described as for the connector on module. These connectors are capable of accommodating the following signals and will be following components.

7.1 TFT LCD Module

7.1.1 Connector

Connector Name / Designation	Interface Connector / Interface card
Manufacturer	JAE / P-TWO
Type Part Number	FI-XB30SSLA-HF15 / 187034-30091
Mating Housing Part Number	FI-X30HL FI-X30H (Unlocked Type)

7.1.2 Pin Assignment

Pin#	Signal Name	Pin#	Signal Name
1	RxOIN0-	2	RxOIN0+
3	RxOIN1-	4	RxOIN1+
5	RxOIN2-	6	RxOIN2+
7	VSS	8	RxOCLKIN-
9	RxOCLKIN+	10	RxOIN3-
11	RxOIN3+	12	RxEIN0-
13	RxEIN0+	14	VSS
15	RxEIN1-	16	RxEIN1+
17	VSS	18	RxEIN2-
19	RxEIN2+	20	RxECLKIN-
21	RxECLKIN+	22	RxEIN3-
23	RxEIN3+	24	VSS
25	VSS	26	NC
27	VSS	28	VCC
29	VCC	30	VCC

AUO confidential for Data Module use only 2014/05/03



7.2 Backlight Unit

Physical interface is described as for the connector on module. These connectors are capable of accommodating the following signals and will be following components.

Connector Name / Designation	LED Connector / Backlight
Manufacturer	STM
Type Part Number	MS24019R
Mating Type Part Number	P24019

7.2.1 Signal for LED connector

Pin #	Symbol	Pin Description
1	+12V	Power +12V
2	+12V	Power +12V
3	+12V	Power +12V
4	NC	NC
5	GND	GND
6	GND	GND
7	GND	GND
8	EN	Enable(0V:disable, 5V:Enable)
9	Dimming	PWM (duty 10%~ 100%)

AUO confidential for Data Modul use only 2012/05/03



8. Reliability Test

Environment test conditions are listed as following table.

Items	Required Condition	Note
Temperature Humidity Bias (THB)	Ta= 50°C, 80%RH, 300hours	
High Temperature Operation (HTO)	Ta= 60°C, 300hours	
Low Temperature Operation (LTO)	Ta= 0°C, 300hours	
High Temperature Storage (HTS)	Ta= 60°C, 300hours	
Low Temperature Storage (LTS)	Ta= -20°C, 300hours	
Vibration Test (Non-operation)	Acceleration: 1.5 G Wave: Random Frequency: 10 - 200 - 10 Hz Sweep: 30 Minutes each Axis (X, Y, Z)	
Shock Test (Non-operation)	Acceleration: 50 G Wave: Half-sine Active Time: 20 ms Direction: ±X, ±Y, ±Z (one time for each Axis)	
Drop Test	Height: 60 cm, package test	
Thermal Shock Test (TST)	-20°C /30min, 60°C /30min, 100 cycles	1
On/Off Test	On/10sec, Off/10sec, 30,000 cycles	
ESD (ElectroStatic Discharge)	Contact Discharge: ± 8KV, 150pF(330Ω) 1sec, 9 points, 25 times/ point.	2
	Air Discharge: ± 15KV, 150pF(330Ω) 1sec 9 points, 25 times/ point.	
Altitude Test	Operation:10,000 ft Non-Operation:30,000 ft	

Note 1: The TFT-LCD module will not sustain damage after being subjected to 100 cycles of rapid temperature change. A cycle of rapid temperature change consists of varying the temperature from -20°C to 60°C, and back again. Power is not applied during the test. After temperature cycling, the unit is placed in normal room ambient for at least 4 hours before power on.

Note 2: According to EN61000-4-2 , ESD class B: Some performance degradation allowed. No data lost. Self-recoverable. No hardware failures.

9. Shipping Label and Packaging

9.1 Shipping Label

The label is on the panel as shown below:



Note 1: For Pb Free products, AUO will add for identification.

Note 2: For RoHS compatible products, AUO will add for identification.

Note 3: For China RoHS compatible products, AUO will add for identification.

Note 4: The Green Mark will be presented only when the green documents have been ready by AUO Internal Green Team.

9.2 Packaging

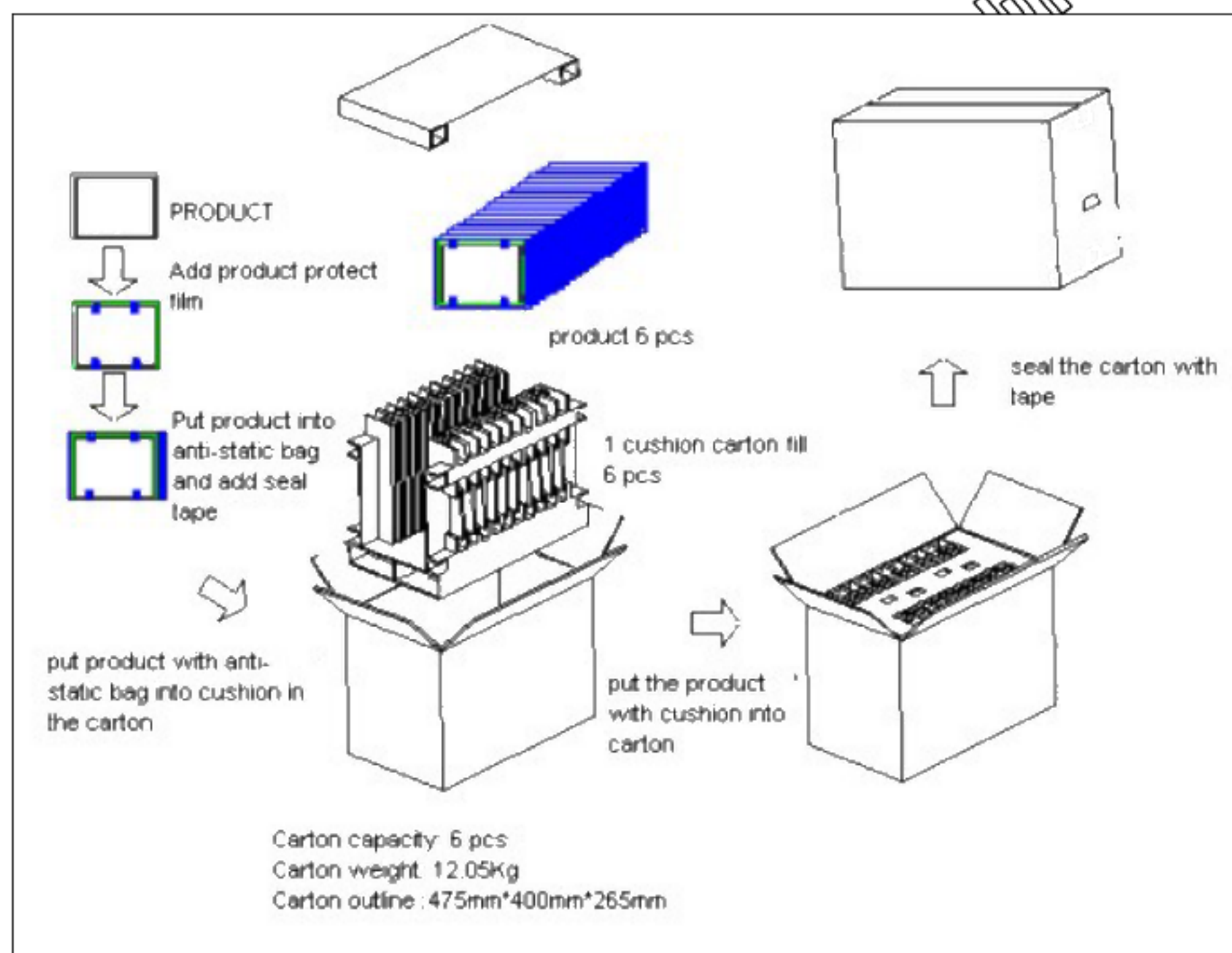

10. Mechanical Characteristic

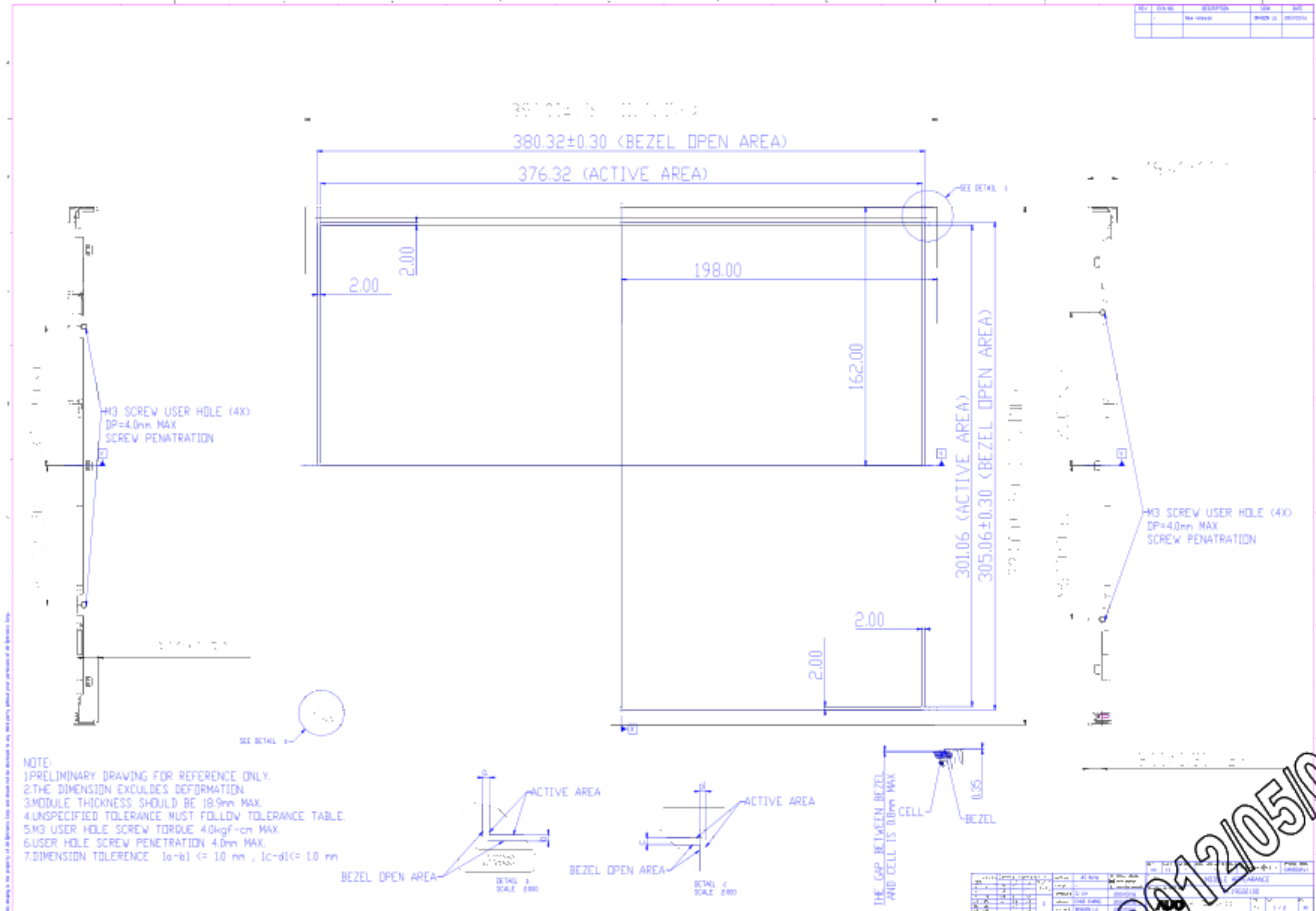

AUO confidential for Data Modul use only 2012/05/03



Product Specification

G190EG02 V1

AU OPTRONICS CORPORATION

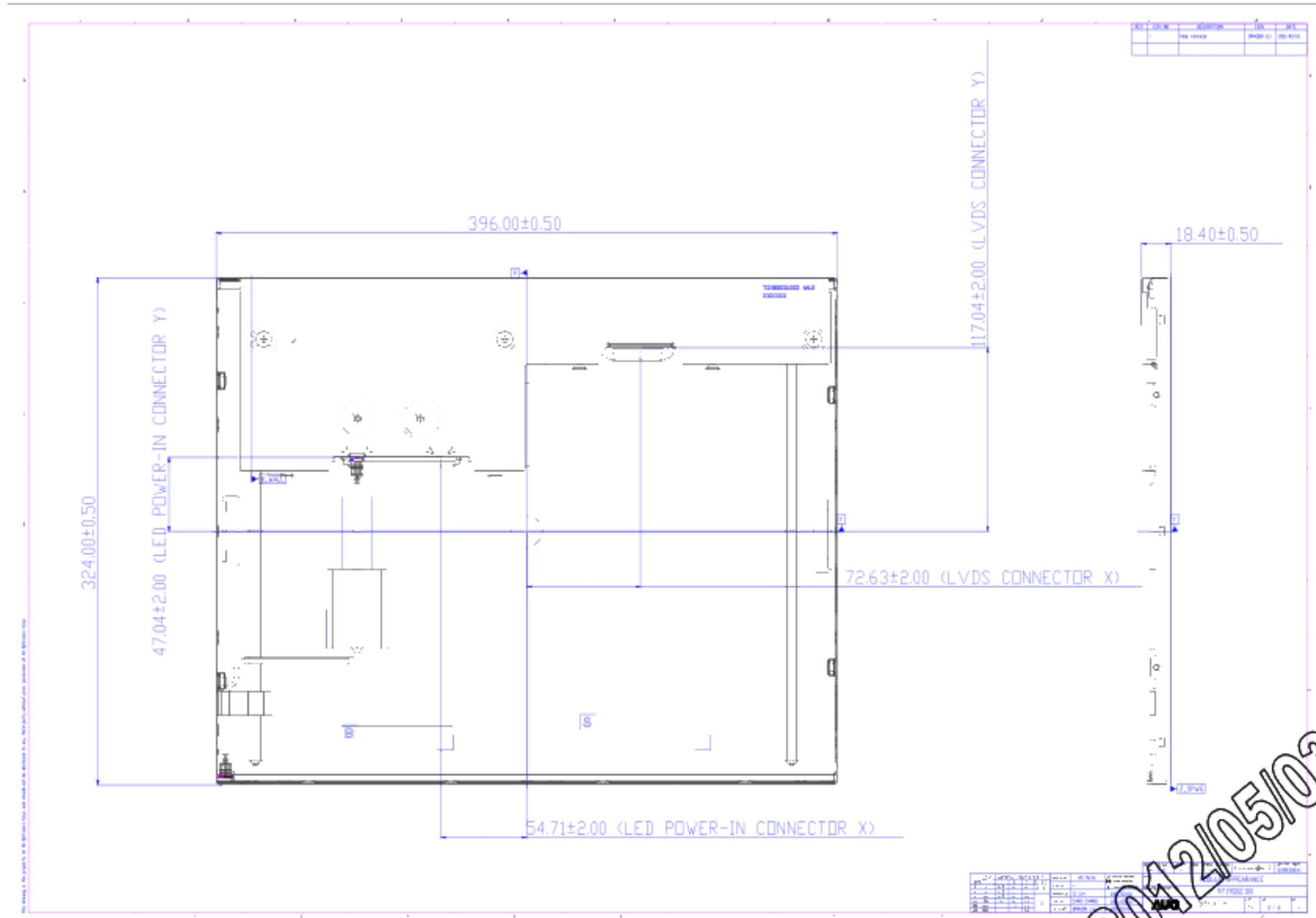

AUO confidential for Data Modul use only 2012/05/03