

No.	LA1-07006 C
DATE	Aug. 6. 2007

TECHNICAL LITERATURE

FOR

TFT - LCD module

MODEL No. LQ035Q3DG01

TENTATIVE

The technical literature is subject to change without notice.
So, please contact Sharp or its representative before
designing your product based on this literature.

SHARP CORPORATION

MOBILE LIQUID CRYSTAL DISPLAY GROUP

NOTICE

This publication is the proprietary of SHARP and is copyrighted, with all rights reserved. Under the copyright laws, no part of this publication may be reproduced or transmitted in any form or by any means, electronic or mechanical for any purpose, in whole or in part, without the express written permission of SHARP. Express written permission is also required before any use of this publication may be made by a third party.

The application circuit examples in this publication are provided to explain the representative applications of SHARP's devices and are not intended to guarantee any circuit design or permit any industrial property right or other rights to be executed. SHARP takes no responsibility for any problems related to any industrial property right or a third party resulting from the use of SHARP's devices, except for those resulting directly from device manufacturing processes.

In the absence of confirmation by device specification sheets, SHARP takes no responsibility for any defects that occur in equipment using any of SHARP's devices, shown in catalogs, data books, etc. Contact SHARP in order to obtain the latest device specification sheets before using any SHARP's device.

SHARP reserves the right to make changes in the specifications, characteristics, data, materials, structures and other contents described herein at any time without notice in order to improve design or reliability. Contact SHARP in order to obtain the latest specification sheets before using any SHARP's device. Manufacturing locations are also subject to change without notice.

Observe the following points when using any device in this publication. SHARP takes no responsibility for damage caused by improper use of the devices.

The devices in this publication are designed for use in general electronic equipment designs, such as:

- Personal computers
- Office automation
- Telecommunication equipment
- Test and measurement equipment
- Industrial control
- Personal Digital Assistant
- Audio visual and multimedia equipment
- Consumer electronics

The appropriate design measures should be taken to ensure reliability and safety when SHARP's devices are used for equipment such as:

- Transportation control and safety equipment(i.e. aircraft, trains, automobiles, etc.)
- Traffic signals
- Gas leakage sensor breakers
- Alarm equipment
- Various safety devices etc.

SHARP's devices shall not be used for equipment that requires extremely high level of reliability, such as:

- Military and space applications
- Nuclear power control equipment
- Medical equipment for life support

Contact a SHARP representative, in advance, when intending to use SHARP's devices for any "specific" applications other than those recommended by SHARP.

Contact and consult with a SHARP representative if there are any questions about the contents of this publication.

1. Applicable Scope

This specification is applicable to TFT-LCD Module "LQ035Q3DG01".

2. General Description

This module is a color active matrix LCD module incorporating amorphous silicon TFT (Thin Film Transistor). It is composed of a color TFT-LCD panel, driver IC, Input FPC, a back light unit.

Graphics and texts can be displayed on a 320 × RGB × 240 dots panel with about 262k colors by supplying 18bit data signals (6bit × RGB), four timing signals, 3wires 9bit serial interface signals, logic (Typ. +3.3V), analog (Typ. +3.3V) supply voltages for TFT-LCD panel driving and supply voltage for back light.

3. Mechanical (Physical) Specifications

Item	Specifications	Unit
Screen size	8.8 (3.5" type) diagonal	cm
Active area	70.56 (H) × 52.92 (V)	mm
Dot format	320 (H) × RGB × 240 (V)	dot
Pixel pitch	0.2205 (H) × 0.2205 (V)	mm
Pixel configuration	R,G,B vertical stripes	-
Display mode	Normally white	-
Unit outline dimensions *	63.9 (W) × 76.9 (H) × (3.5) (D)	mm
Mass	Approx. 33	g
Surface treatment	Anti glare	-

*The above-mentioned table indicates module sizes without some projections and FPC.
For detailed measurements and tolerances, please refer to 17. Outline Dimensions.

4. Input Terminal Names and Functions

Recommendation CN : [HIROSE] FH26G-67S-0.3SHBW(05)

Pin No.	Symbol	I/O	Description	Remarks
1	LED_C (-)	-	Power supply for LED (Low voltage)	
2	LED_A(+)	-	Power supply for LED (High voltage)	
3	DGND1	-	Digital Ground	
4	NC	-	Not connected	Note 1
5	NC	-	Not connected	Note 1
6	NC	-	Not connected	Note 1
7	NC	-	Not connected	Note 1
8	AGND1	-	Analog Ground	
9	V _{GH}	-	Connect to a Stabilizing capacitor	Note 3
10	C2P	-	Connect a Booster capacitor to C2N	Note 2
11	C2N	-	Connect a Booster capacitor to C2P	
12	C1P	-	Connect a Booster capacitor to C1N	
13	C1N	-	Connect a Booster capacitor to C1P	
14	V _{GL}	-	Connect a Stabilizing capacitor to GND	Note 3
15	C3P	-	Connect a Booster capacitor to C3N	Note 2
16	C3N	-	Connect a Booster capacitor to C3P	
17	AGND2	-	Analog Ground	
18	V _{CIX2}	-	Connect a Stabilizing capacitor to GND	Note 3
19	CYP	-	Connect a Booster capacitor to CYN	Note 2
20	CYN	-	Connect a Booster capacitor to CYP	
21	V _{CI}	-	3.3V(Booster input voltage pin)	Note 3
22	NC	-	Not connected	Note 1
23	AGND3	-	Analog Ground	
24	V _{CIM}	-	Connect a Stabilizing capacitor to GND	Note 3
25	CXP	-	Connect a Booster capacitor to CXN	Note 2
26	CXN	-	Connect a Booster capacitor to CXP	
27	TEST	O	TEST	Note 1
28	RESB	I	System reset	
29	DGND2	-	Digital Ground	
30	V _{DDIO}	-	3.3V(Voltage input pin for logic I/O)	
31	V _{CORE}	-	Connect a Stabilizing capacitor to GND	Note 3
32	DGND3	-	Digital Ground	
33	SHUT	I	Sleep mode control	
34	CSB	I	Chip select pin of serial interface	
35	SDI	I	Data input pin in serial mode	
36	SCK	I	Clock input pin in serial mode	
37	V _{DROP}	-	Connect a Stabilizing capacitor	
38	DEN	I	Display enable	
39	B5	I	BLUE data signal(MSB)	
40	B4	I	BLUE data signal	
41	B3	I	BLUE data signal	

Pin No.	Symbol	I/O	Description	Remarks
42	B2	I	BLUE data signal	
43	B1	I	BLUE data signal	
44	B0	I	BLUE data signal(LSB)	
45	G5	I	GREEN data signal(MSB)	
46	G4	I	GREEN data signal	
47	G3	I	GREEN data signal	
48	G2	I	GREEN data signal	
49	G1	I	GREEN data signal	
50	G0	I	GREEN data signal(LSB)	
51	R5	I	RED data signal(MSB)	
52	R4	I	RED data signal	
53	R3	I	RED data signal	
54	R2	I	RED data signal	
55	R1	I	RED data signal	
56	R0	I	RED data signal(LSB)	
57	VSYNC	I	Frame synchronization signal	
58	HSYNC	I	Line synchronization signal	
59	DOTCLK	I	Dot-clock signal	
60	CDUM0	-	Connect a Stabilizing capacitor to GND	Note 3
61	DGND4	-	Digital Ground	
62	V _{LCD63}	-	Connect a Stabilizing capacitor to GND	Note 3
63	V _{COMH}	-	Connect a Stabilizing capacitor to GND	
64	V _{COML}	-	Connect a Stabilizing capacitor to GND	
65	DGND5	-	Digital Ground	
66	CSVCMP	-	Connect a Stabilizing capacitor to CSVCMN	Note 3
67	CSVCMN	-	Connect a Stabilizing capacitor to CSVCMP	

Note 1) this pin should be opened.

Note 2) Booster Capacitors

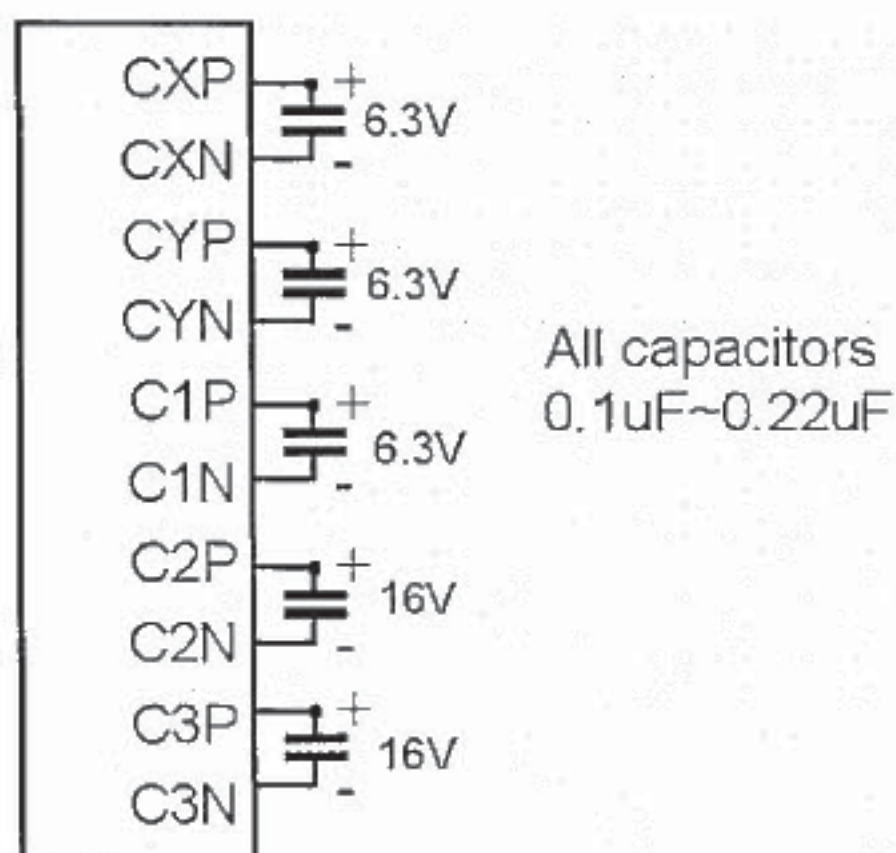

Note 3) Stabilization and charge sharing Capacitors

Mandatory requirement on external components for LQ035Q3DG01 is 16 capacitors.

VCIX2,VCIM,CDUM0,VGH,VGL,VCIP,VCORE,VCOMH,VCOML,VLCD63

CSVCMN,C1P/C1N,C2P/C2N,C3P/3N,CYP/CYN,CXP/CXN

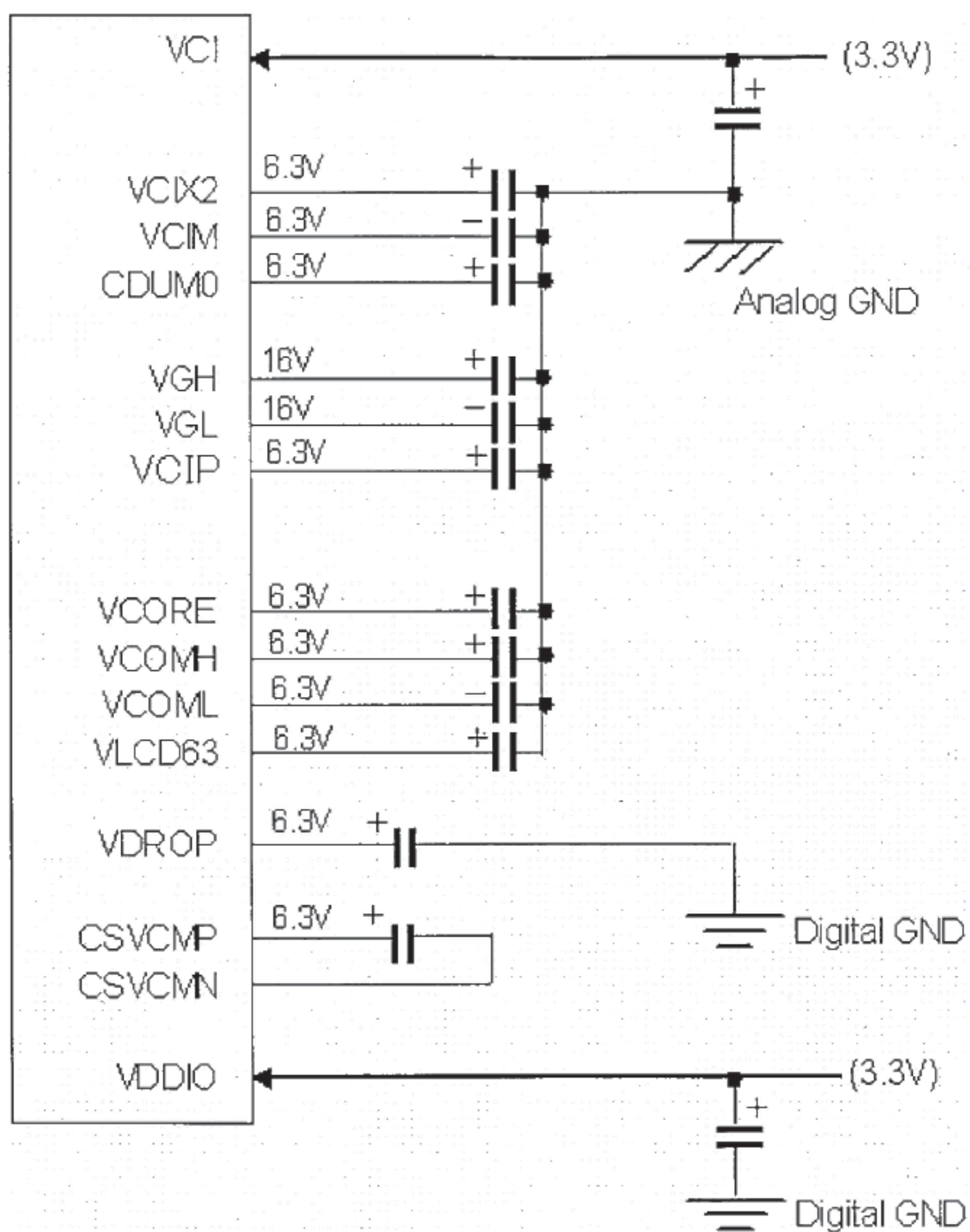

Remark:

Capacitor for VCIX2=2.2uF

All other capacitors 1.0uF ~ 2.2uF(2.2uF is preferred for better display quality and power consumption.)

5. Absolute Maximum Ratings

Item	Symbol	Conditions	Rated value	Unit	Remarks
Input voltage	V_I	$T_a = 25^\circ\text{C}$	$-0.3 \sim V_{DDIO}+0.3$	V	Note 1
Logic I/O power supply voltage	V_{DDIO}	$T_a = 25^\circ\text{C}$	$-0.3 \sim +4.0$	V	
Analog power supply voltage	V_{CI}	$T_a = 25^\circ\text{C}$	AGND-0.3 ~ +5.0	V	
Temperature for storage	T_{stg}	-	$-30 \sim +85$	$^\circ\text{C}$	Note 2
Temperature for operation	T_{opp}	-	$-20 \sim +70$	$^\circ\text{C}$	Note 3
LED input electric current	I_{LED}	$T_{aLED} = 25^\circ\text{C}$	35	mA	
LED electricity consumption	P_{LED}	$T_{aLED} = 25^\circ\text{C}$	123	mW	

Note 1) RESB, SHUT, CSB, SDI, SCK, DEN, B5~B0, G5~G0, R5~R0, VSYNC, HSYNC, DOTCLK

Note 2) Humidity: 95%RH Max. ($T_a \leq 40^\circ\text{C}$)

Maximum bulb temperature under 39°C ($T_a > 40^\circ\text{C}$) See to it that no dew will be condensed.

Note 3) Panel surface temperature prescribes.

Note 4) Power consumption of one LED ($T_{aLED} = 25^\circ\text{C}$). (use 7 pieces LED)

Ambient temperature and the maximum input are fulfilling the following operating conditions.

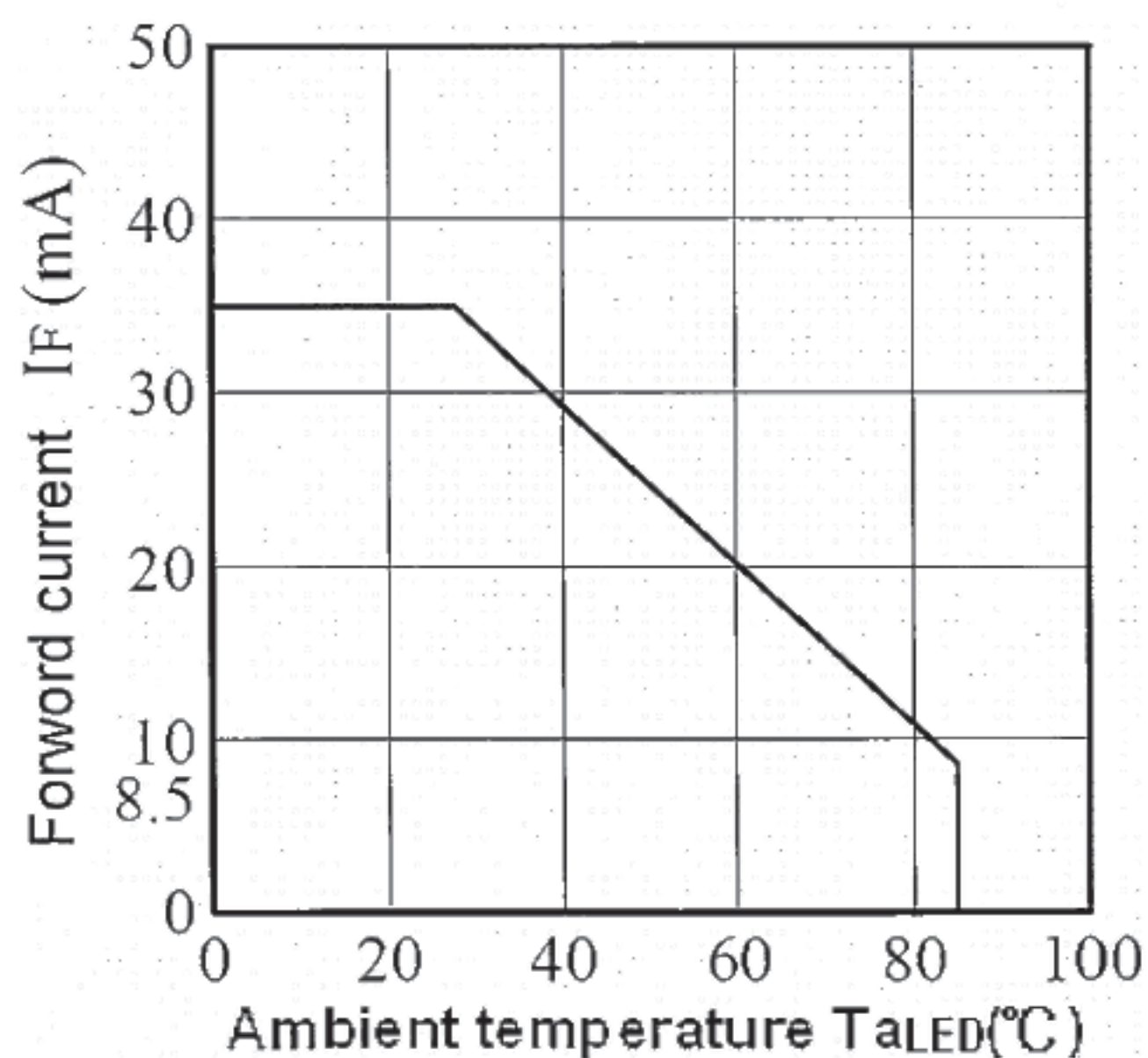

Ambient temperature of LED and the maximum input

6. Electrical Characteristics

6-1. TFT LCD Panel Driving

Ta = 25°C

Item		Symbol	Min.	Typ.	Max.	Unit	Remarks
Logic I/O power supply	DC voltage	V_{DDIO}	+3.0	+3.3	+3.6	V	
	DC Current	I_{VDDIO}	-	(0.20)	(0.35)	mA	Note 1
Analog power supply	DC voltage	V_{CI}	+3.0	+3.3	+3.6	V	
	DC Current	I_{VCI}	-	(8.0)	(12.0)	mA	Note 1
Permissive input Ripple voltage		$V_{RFVDDIO}$	-	-	(100)	mVp-p	Note 2
		V_{RFVCI}	-	-	(100)	mVp-p	Note 2
Logic Input Voltage	High	V_{IH}	$0.8 V_{DDIO}$	-	V_{DDIO}	V	Note3
	Low	V_{IL}	0	-	$0.2 V_{DDIO}$	V	Note3
Logic input Current		I_{IH} / I_{IL}	-1	-	1	μA	Note 3

Note 1) $V_{DDIO} = V_{CI} = +3.3V$ Current situation for I_{VDDIO} : Black & White checker flag patternCurrent situation for I_{CI} : All black patternNote 2) $V_{DDIO} = V_{CI} = +3.3V$

Note 3) RESB, SHUT, CSB, SDI, SCK, DEN, B5~B0, G5~G0, R5~R0, VSYNC, HSYNC, DOTCLK

6-2. Register Setting

Reg. #	Register	Data (Gamma 2.2)	Remark
R01 h	Driver output control	2xEF h	
R02 h	LCD drive AC control	0300 h	
R03 h	Power control (1)	7A7E h	
R0B h	Frame cycle control	DC00 h	
R0C h	Power control (2)	0005 h	
R0D h	Power control (3)	0002 h	
R0E h	Power control (4)	2900 h	
R0F h	Gate scan starting Position	0000 h	
R16 h	Horizontal Porch	9F86 h	Note1
R17 h	Vertical Porch	0002 h	Note2
R1E h	Power control (5)	0000 h	
R28 h	Power control (6)	0006 h	
R2C h	Power control (7)	C88C h	
R2E h	3 Gamma	B945 h	
R30 h	Gamma control (1)	0000 h	
R31 h	Gamma control (1)	0707 h	
R32 h	Gamma control (1)	0003 h	
R33 h	Gamma control (1)	0401 h	
R34 h	Gamma control (1)	0307 h	
R35 h	Gamma control (1)	0000 h	
R36 h	Gamma control (1)	0707 h	
R37 h	Gamma control (1)	0204 h	
R3A h	Gamma control (2)	0D0B h	
R3B h	Gamma control (2)	0D0B h	
R40 h	Gamma control (3)	0000 h	
R41 h	Gamma control (3)	0707 h	
R42 h	Gamma control (3)	0003 h	
R43 h	Gamma control (3)	0401 h	
R44 h	Gamma control (3)	0307 h	
R45 h	Gamma control (3)	0000 h	
R46 h	Gamma control (3)	0707 h	
R47 h	Gamma control (3)	0204 h	
R4A h	Gamma control (4)	0D0B h	
R4B h	Gamma control (4)	0D0B h	
R50 h	Gamma control (5)	0000 h	
R51 h	Gamma control (5)	0707 h	
R52 h	Gamma control (5)	0003 h	
R53 h	Gamma control (5)	0401 h	
R54 h	Gamma control (5)	0307 h	
R55 h	Gamma control (5)	0000 h	
R56 h	Gamma control (5)	0707 h	
R57 h	Gamma control (5)	0204 h	
R5A h	Gamma control (6)	0D0B h	
R5B h	Gamma control (6)	0D0B h	

Note 1)

Driver Output Control (R01h)(POR=2xEFh)

	DC	IB15	IB14	IB13	IB12	IB11	IB10	IB9	IB8	IB7	IB6	IB5	IB4	IB3	IB2	IB1	IB0
W	1	0	0	1	0	1	0	TB	RL	1	1	1	0	1	1	1	1
POR		0	0	1	0	1	0	x	x	1	1	1	0	1	1	1	1

«Vertical and Horizontal inversion function(TB, RL)»

(TB="1" , RL="0")

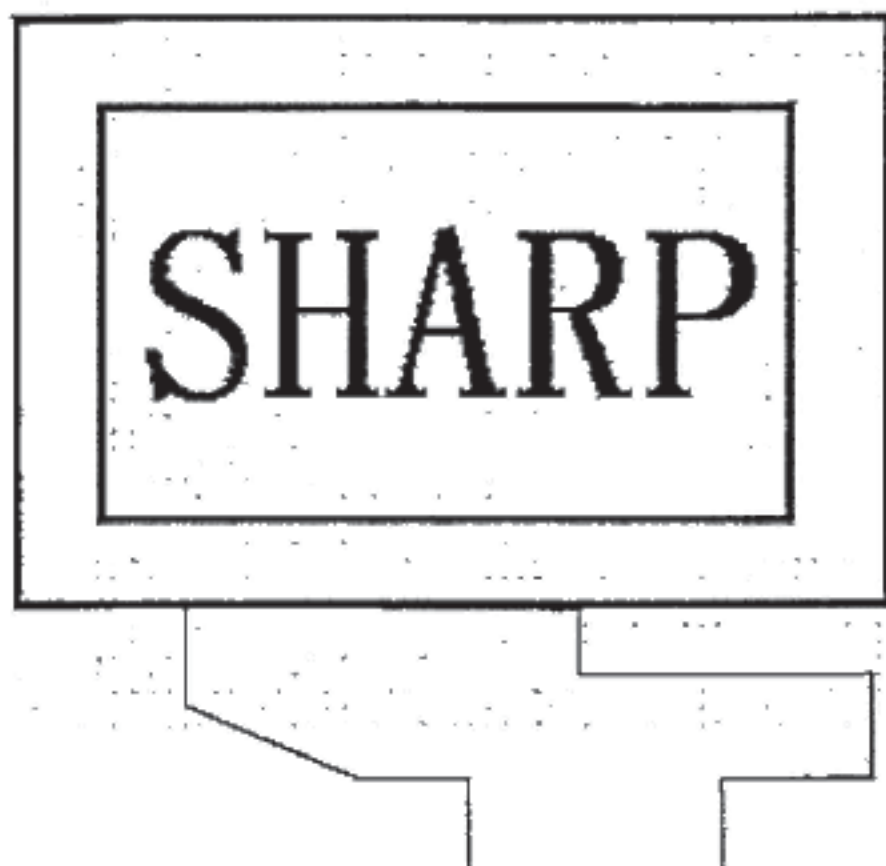

(TB="1" , RL="1")



(TB="0" , RL="0")



(TB="0" , RL="1")

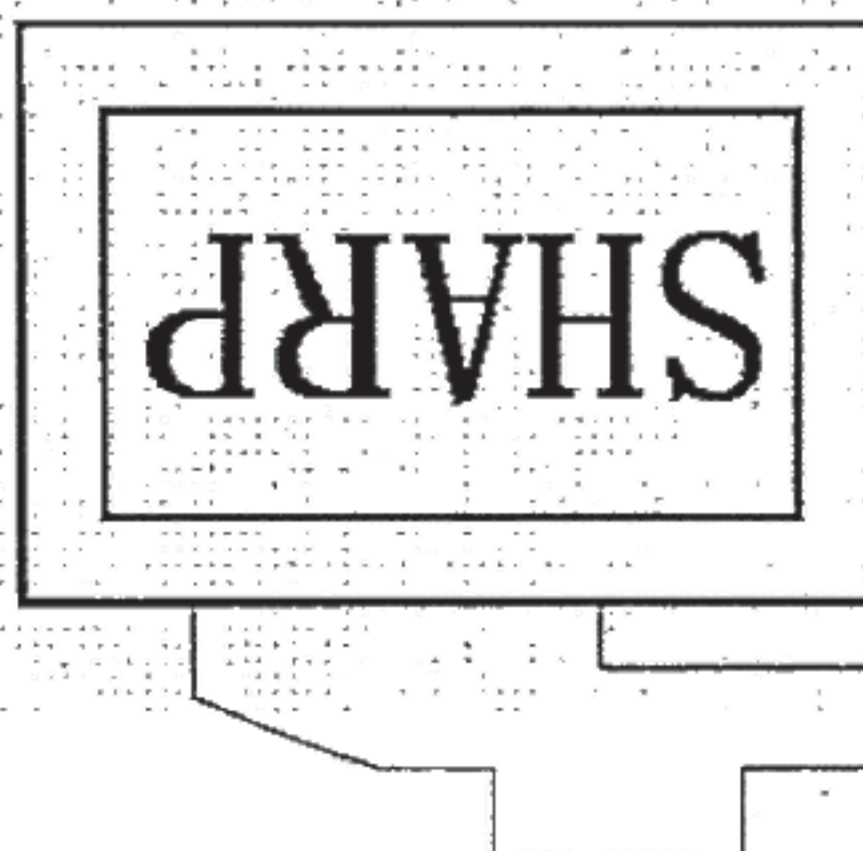

Note 2)

Horizontal Porch(R16h)(POR=9F86h)

	RW	DC	IB15	IB14	IB13	IB12	IB11	IB10	IB9	IB8	IB7	IB6	IB5	IB4	IB3	IB2	IB1	IB0
W	1	1	1	0	0	1	1	1	1	1	1	0	HBP5	HBP4	HBP3	HBP2	HBP1	HBP0
POR		1	0	0	0	1	1	1	1	1	1	0	0	0	0	1	1	0

HBP5-0: Set the delay period from falling edge of HSYNC to first valid line.

HBP5	HBP4	HBP3	HBP2	HBP1	HBP0	No. of clock cycle of DOTCLK
0	0	0	0	0	0	2
0	0	0	0	0	1	3
0	0	0	0	1	0	4
0	0	0	0	1	1	5
0	0	0	1	0	0	6
⋮						⋮
⋮						Step = 1
⋮						⋮
1	1	1	1	1	0	64
1	1	1	1	1	1	65

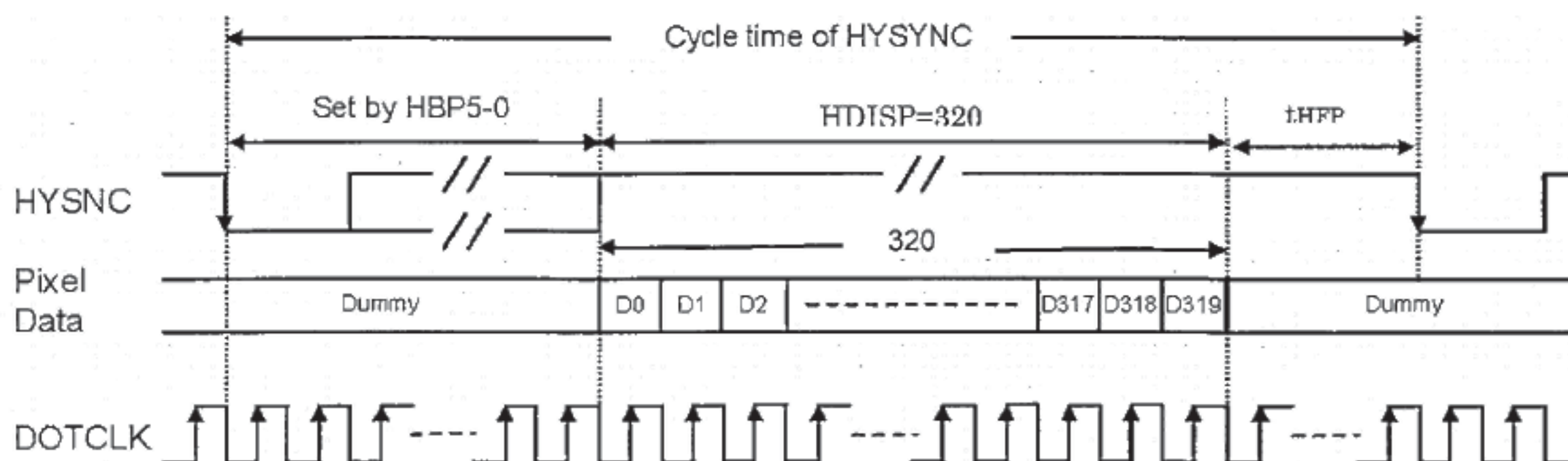

Note 3)

Vertical Porch(R17h)(POR=0002h)

RW	DC	IB15	IB14	IB13	IB12	IB11	IB10	IB9	IB8	IB7	IB6	IB5	IB4	IB3	IB2	IB1	IB0
W	1	0	0	0	0	0	0	0	VBP8	VBP7	VBP6	VBP5	VBP4	VBP3	VBP2	VBP1	VBP0
POR		0	0	0	0	0	0	0	0	0	0	0	0	0	0	1	0

VBP8-0 : Set the delay period from falling edge of VSYNC to first valid line.

VBP8	VBP7	VBP6	VBP5	VBP4	VBP3	VBP2	VBP1	VBP0	No. of clock cycle of HSYNC
0	0	0	0	0	0	0	0	0	0(CAD=0 の場合のみ)
0	0	0	0	0	0	0	0	1	1
0	0	0	0	0	0	0	1	0	2
⋮									⋮
⋮									Step = 1
⋮									⋮
1	0	0	1	1	1	1	1	0	319
1	0	0	1	1	1	1	1	1	320
1	0	1	*	*	*	*	*	*	Reserved
1	1	*	*	*	*	*	*	*	Reserved

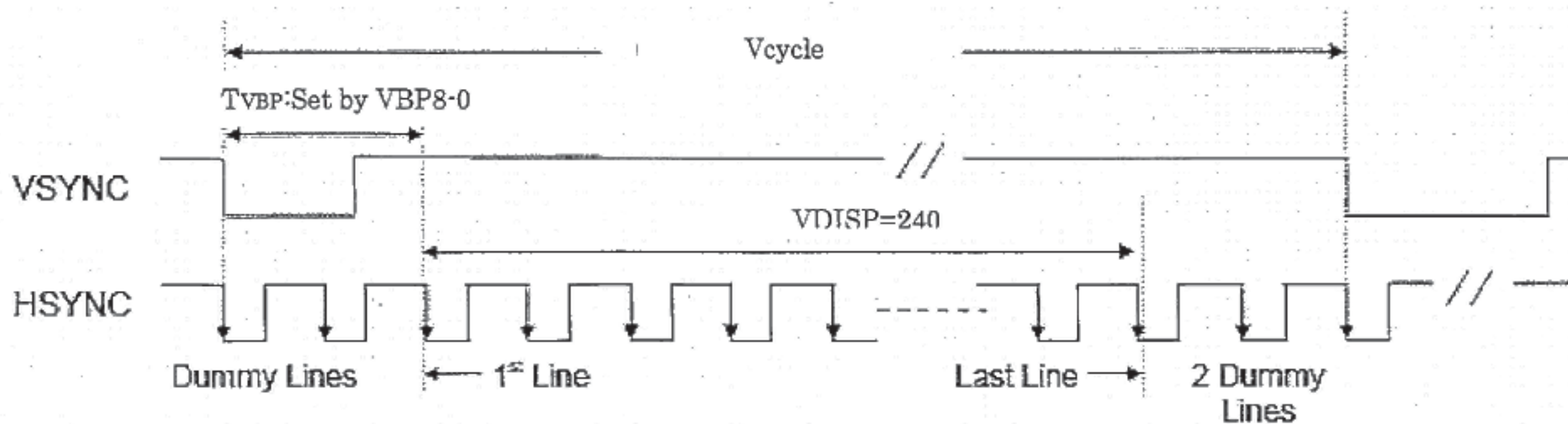

6-3. Back light driving

The back light system has 7 LEDs

[NSSW020B]

Parameter	Symbol	Min.	Typ.	Max.	Unit	Remark
Rated Voltage	V_{BL}	-	22.4	24.5	V	
Rated Current	I_L	-	20	-	mA	$T_{aLED}=25^{\circ}\text{C}$
Power consumption	W_L	-	448	-	mW	

7. Timing characteristics of input signals

7-1. Pixel Clock Timing

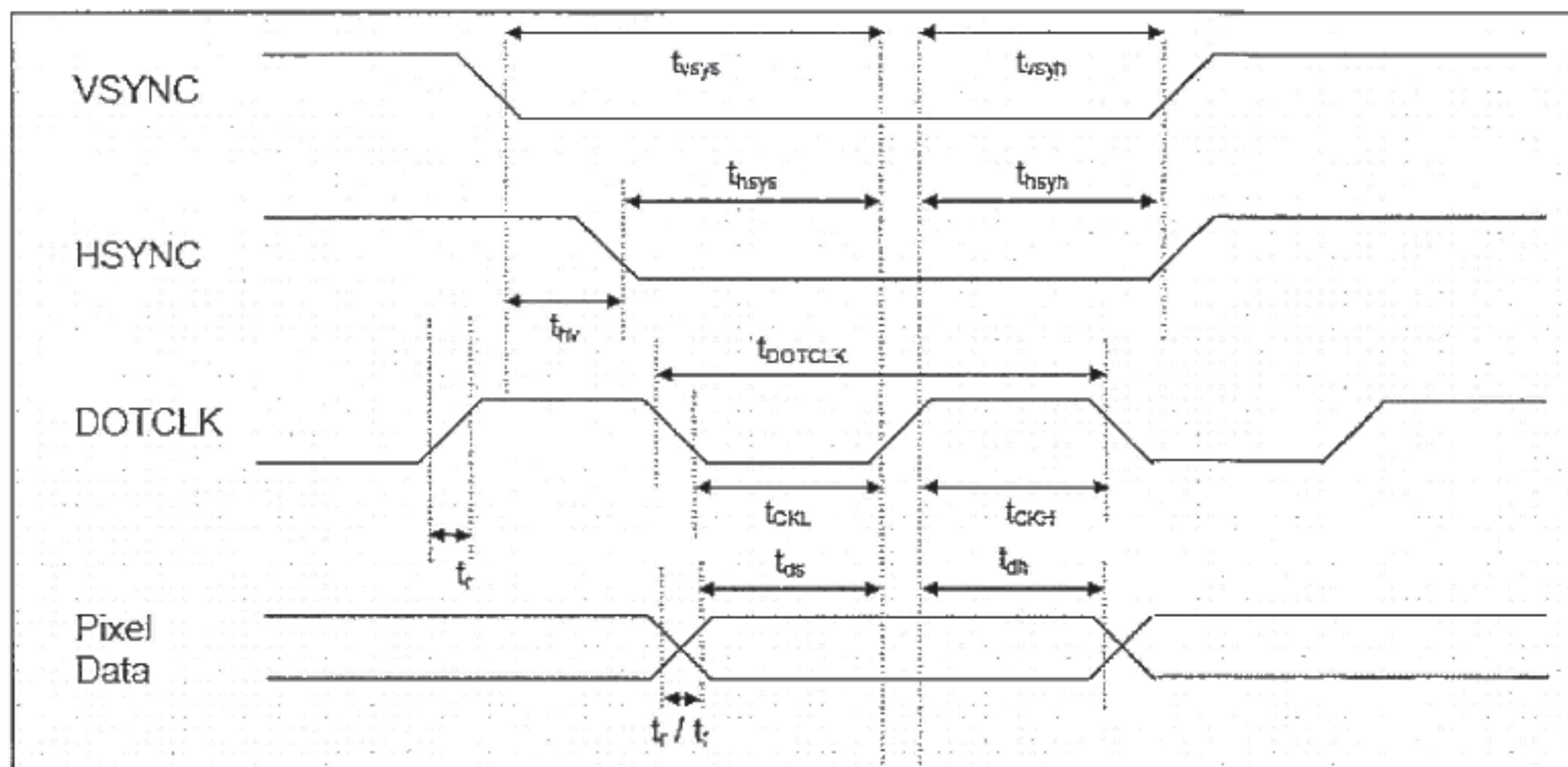

Characteristics		Symbol	Min	Typ	Max	Unit
DOTCLK	Frequency	f_{DOTCLK}	-	5.0	8.0	MHz
	Period	t_{DOTCLK}	125	200	-	nSec
	High Period	t_{CKH}	62	-	-	nSec
	Low Period	t_{CKL}	62	-	-	nSec
Data	Setup Time	t_{ds}	30	-	-	nSec
	Hold Time	t_{dh}	30	-	-	nSec
Vsync	Setup Time	t_{vsys}	20	-	-	nSec
	Hold Time	t_{vsyh}	20	-	-	nSec
Hsync	Setup Time	t_{hsys}	20	-	-	nSec
	Hold Time	t_{hsyh}	20	-	-	nSec
Phase difference of Sync signal Falling edge		t_{hv}	0	-	320	t_{DOTCLK}
Reset Pulse Width		t_{RES}	10	-	-	nSec
Rise / Fall Time		t_r/t_f	20	-	100	nSec

Note: External clock source must be provided to DOTCLK pin.

The module will not operate if absent of the clocking signal.

7-2. Data Transaction Timing in Normal Operating Mode (262k color)

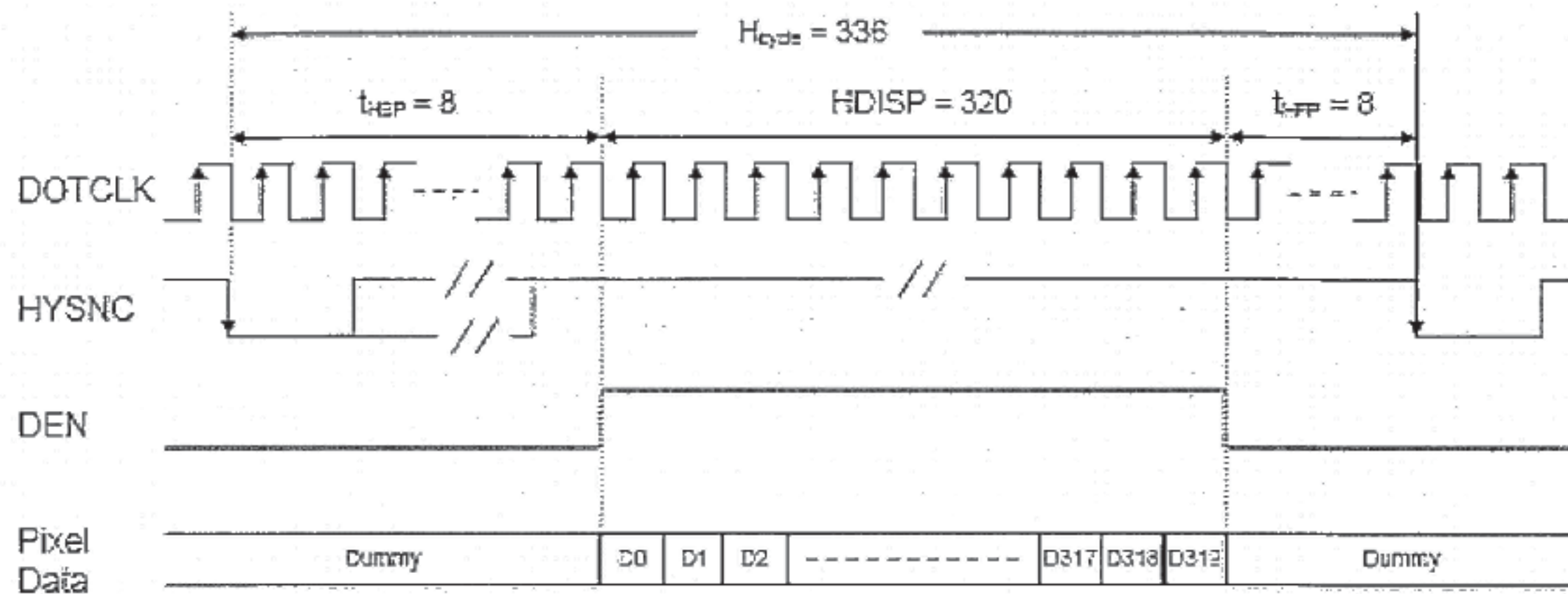

a) Horizontal Data Transaction Timing

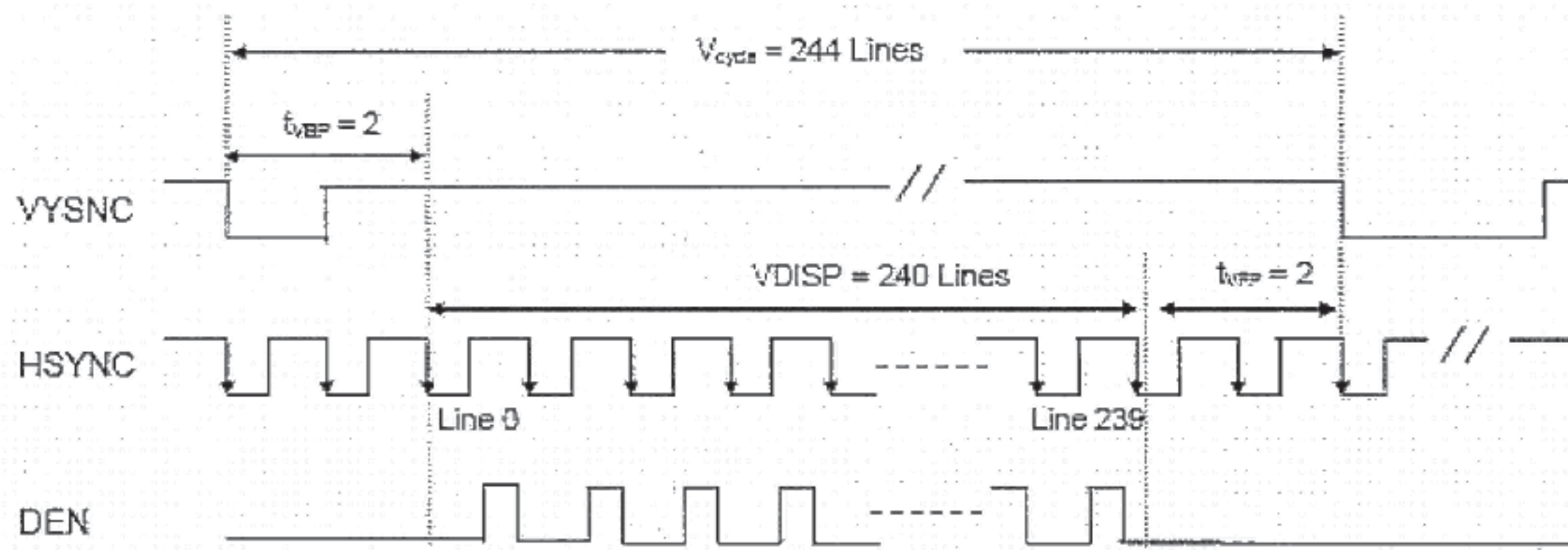

b) Vertical Data Transaction Timing

Characteristics		Symbol	Min	Typ	Max	Unit
DOTCLK	Frequency	f_{DOTCLK}	-	5.0	8.0	MHz
	Period	t_{DOTCLK}	125	200	-	ns
HSYNC	Frequency	f_{h}	-	14.9	18.18	kHz
	Cycle	H_{cycle}	-	336	-	clock
VSYNC	Frequency	f_{v}	50	60.1	-	Hz
	Cycle	V_{cycle}	-	244	-	line
Horizontal Back Porch		t_{HBP}	-	8	-	clock
Horizontal Front Porch		t_{HFP}	-	8	-	clock
Horizontal Data Start Point		t_{HBP}	-	8	-	clock
Horizontal Blanking Period		$t_{\text{HBP}}+t_{\text{HFP}}$	-	16	-	clock
Horizontal Display Area		HDISP	-	320	-	clock
Vertical Back Porch		t_{VBP}	-	2	-	line
Vertical Front Porch		t_{VFP}	-	2	-	line
Vertical Data Start Point		t_{VBP}	-	2	-	line
Vertical Blanking Period		$t_{\text{HBP}}+t_{\text{HFP}}$	-	4	-	line
Vertical Display Area		VDISP	-	240	-	line

7-3. Synchronization Signals Timing in Power Save Mode (8 color)

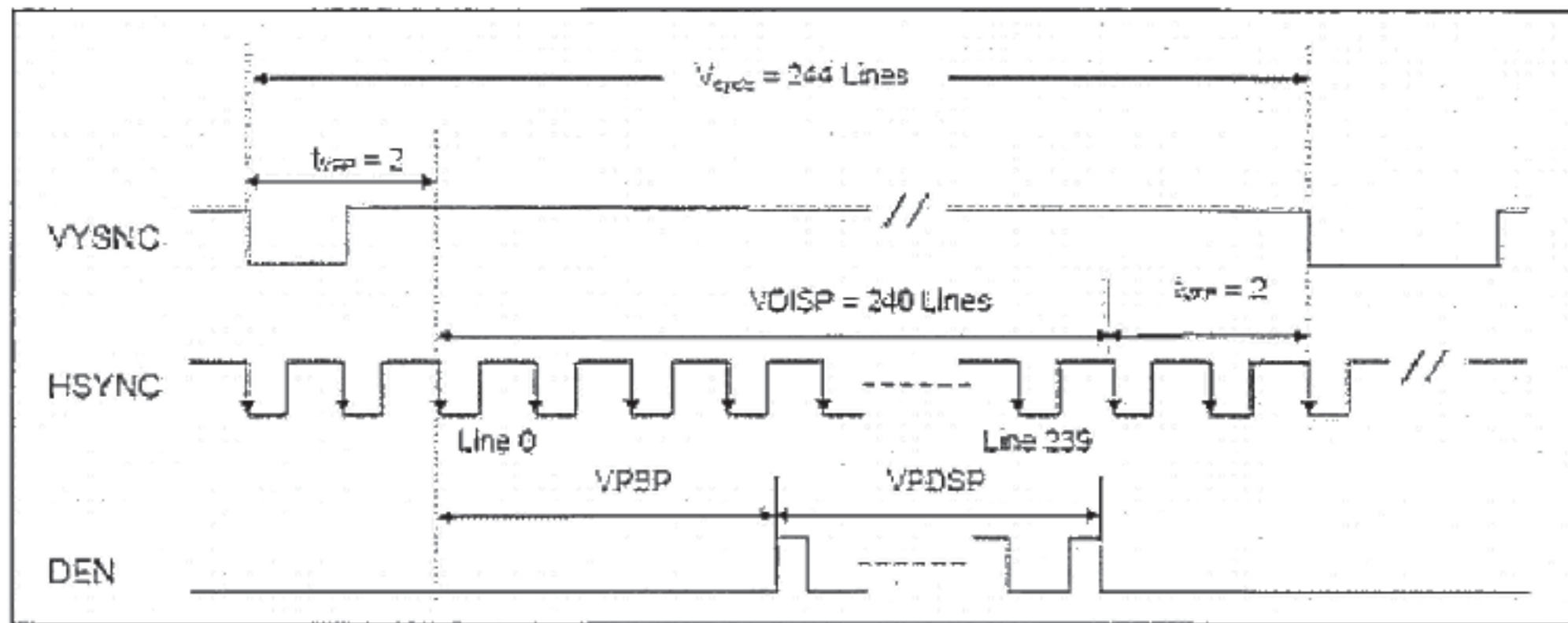

Characteristics		Symbol	Min	Typ	Max	Unit
DOTCLK	Frequency	f_{DOTCLK}	-	5.0	8.0	MHz
	Period	t_{DOTCLK}	125	200	-	ns
HSYNC	Frequency	f_h	-	14.9	18.18	kHz
VSYNC	Frequency	f_v	50	60.1	-	Hz
	Cycle	V_{cycle}	-	244	-	line
Vertical Partial Back Porch		VPBP	0	-	239	line
Vertical Active Area		VPDSP	1	-	240	line
Vertical Back Porch		t_{VBP}	-	2	-	line
Vertical Front Porch		t_{VFP}	-	2	-	line
Vertical Display Area		VDISP	-	240	-	line

Note : When entered to 8-color display mode, the RGB graphic data through the interface pin RR5,GG5 and BB5 are valid within the Vertical Active Area. Data "0" will be displayed the Vertical Active Area.

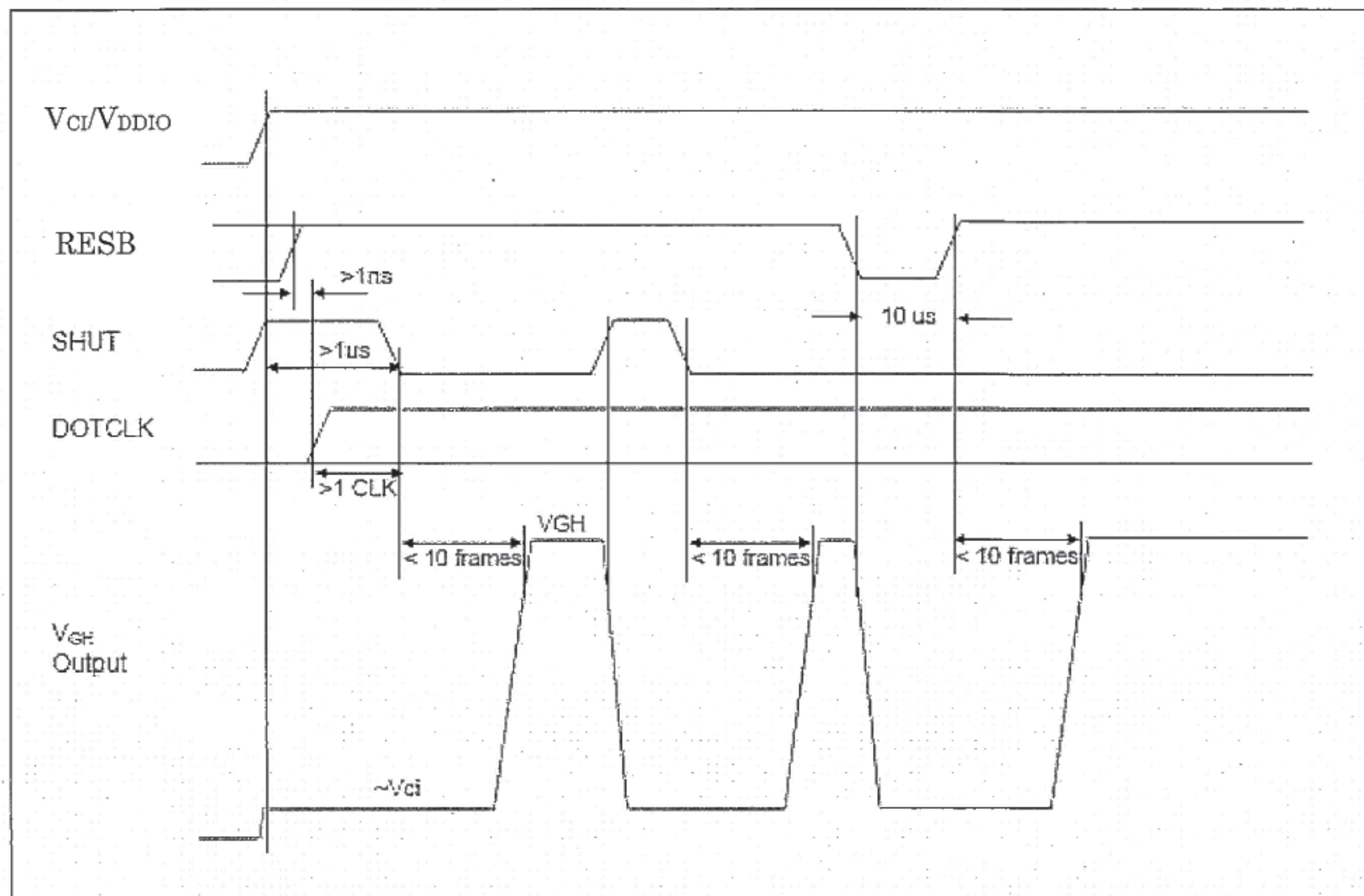
7-4. V_{GH} Output against SHUT & RESB

VGH Output against SHUT & RESB

- Note1: The minimum cycle time of SHUT is $10 \div 2$ frames.
- Note2: DOTCLK must be provided for boosting of V_{GH} . The above timing diagram assumed voltages and DOTCLK are continuous supplied after power on.
- Note3: V_{GH} will be forced to V_{ci} at the low stage of $RESB$.
- Note4: The minimum pulse width of RESET is $10\ \mu s$.

7-5. Power Up Sequence

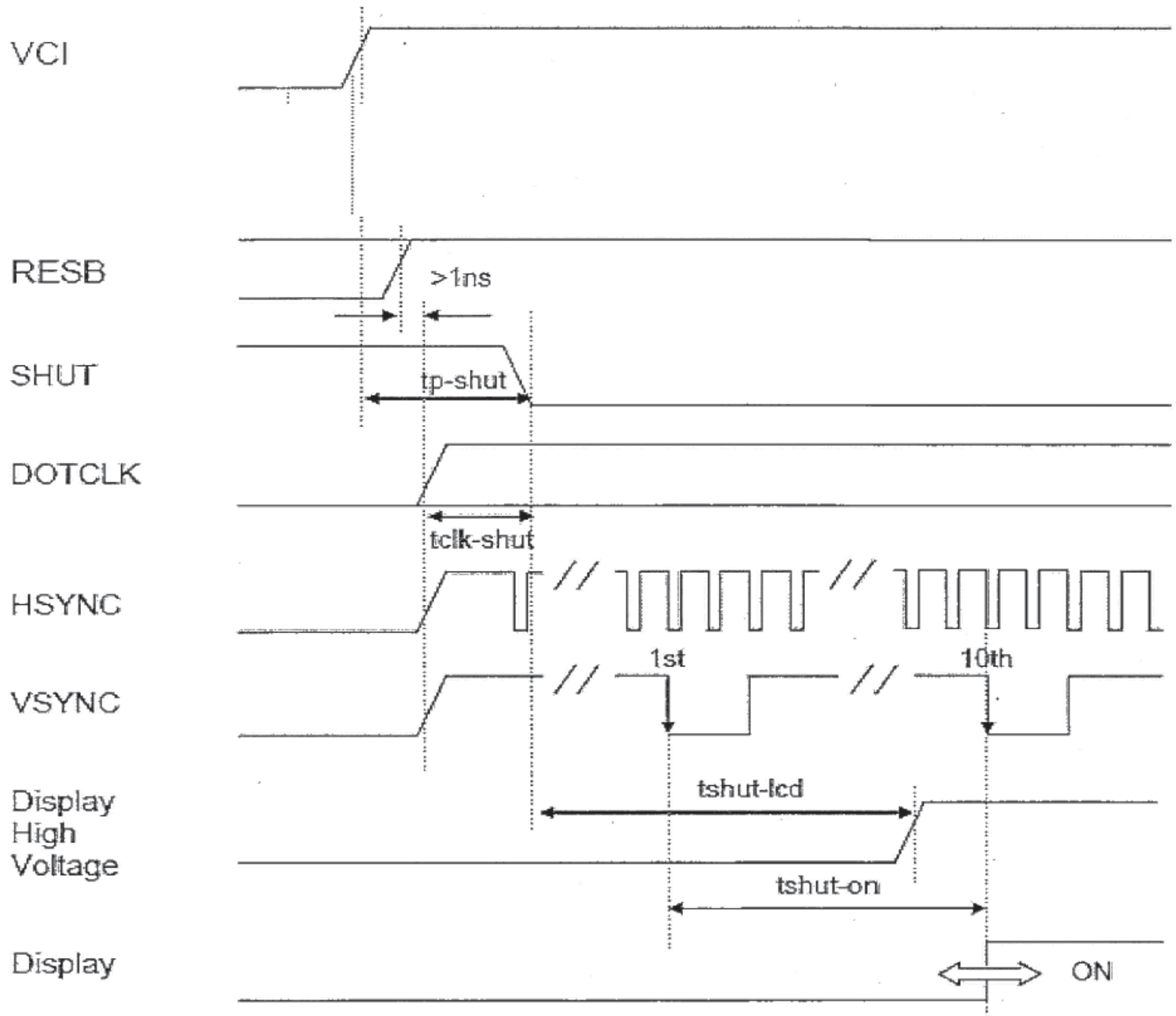

Characteristics	Symbol	Min	Typ	Max	Units
V_{DDEXT} / V_{DDIO} on to falling edge of SHUT	$tp-shut$	1	-	-	μsec
DOTCLK	$tclk-shut$	1	-	-	clk
Falling edge of SHUT to LCD power on	$tshut-lcd$	-	-	164	msec
Falling edge of SHUT to display start	$tshut-on$	-	-	10	frame
- 1 line: 336 clk		-	164	-	msec
- 1 frame: 244 line		-	-	-	-
- DOTCLK = 5.0MHz					

Note1: It is necessary to input DOTCLK before the falling edge of SHUT.

Note2: Display starts at 10th falling edge of VSYNC after the falling edge of SHUT.

7-6. Power Down Sequence

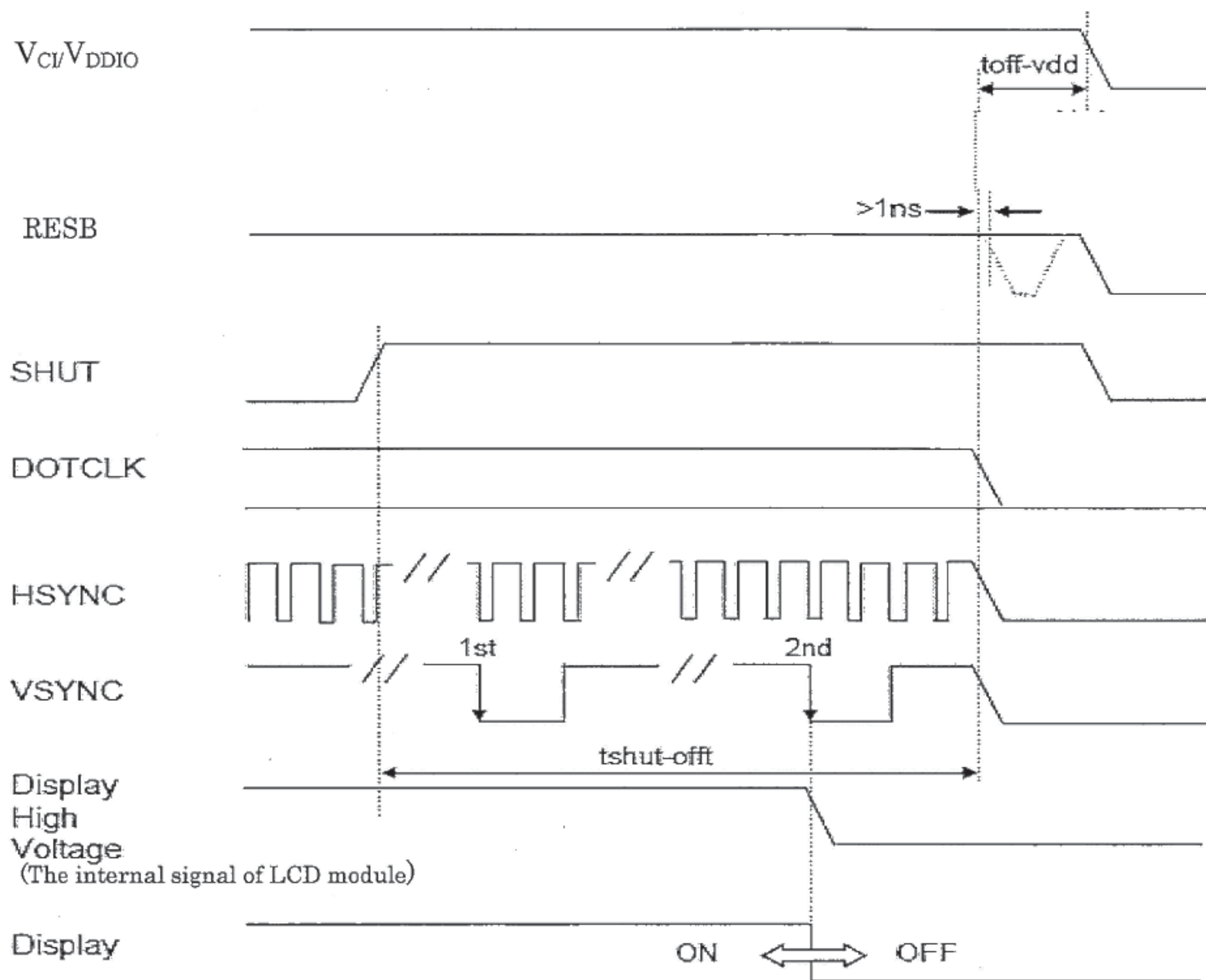

Characteristics	Symbol	Min	Typ	Max	Units
Rising edge of SHUT to display off	tshut-off	2	-	-	frame
- 1 line: 336 clk - 1 frame: 244 line - DOTCLK = 5.0 MHz		32.8	-	-	msec
Input-signal-off to V _{DDEXT} / V _{DDIO} off	toff-vdd	1	-	-	μsec

Note1: DOTCLK must be maintained at least 2 frames after the rising edge of SHUT.

Note2: Display become off at the 2nd falling of VSYNC after the falling edge of SHUT.

Note3: IF RESET(RES) signal is necessary for power down, provide it after the 2-frames cycle of the SHUT period.

7-7. SPI Interface Timing Diagram & Transaction Example (9 bit)

The clock synchronized serial peripheral interface (SPI) using the chip select line (CSB), serial transfer clock line (SCK), serial input data (SDI). The serial data transfer starts at the falling edge of CSB input and ends at the rising edge of CSB. DC bit determinate the data of SDI which is register or data.

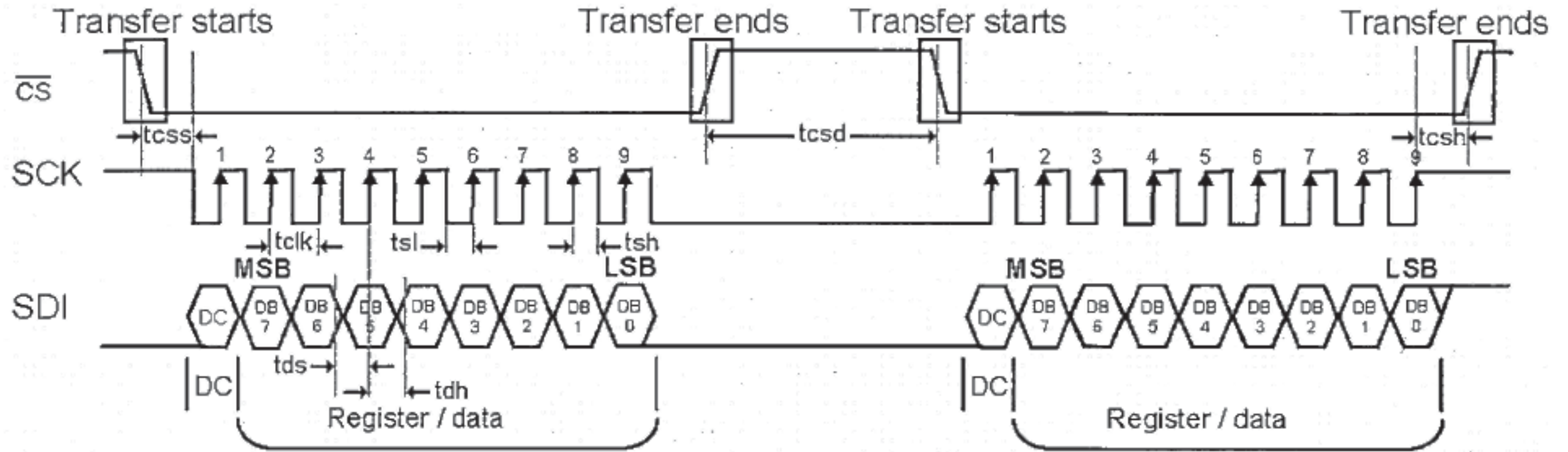

Characteristics	Symbol	Min	Typ	Max	Units
Serial Clock Frequency	fclk	-	-	20	MHz
Serial Clock Cycle Time	tclk	50	-	-	nsec
Clock Low Width	tsl	25	-	-	nsec
Clock High Width	tsh	25	-	-	nsec
Chip Select Setup Time	tcss	0	-	-	nsec
Chip Select Hold Time	tcsd	10	-	-	nsec
Chip Select High Delay Time	tcsd	20	-	-	nsec
Data Setup Time	tds	5	-	-	msec
Data Hold Time	tdh	10	-	-	nsec

The example transmit "0x2AEFh" to register R01h.

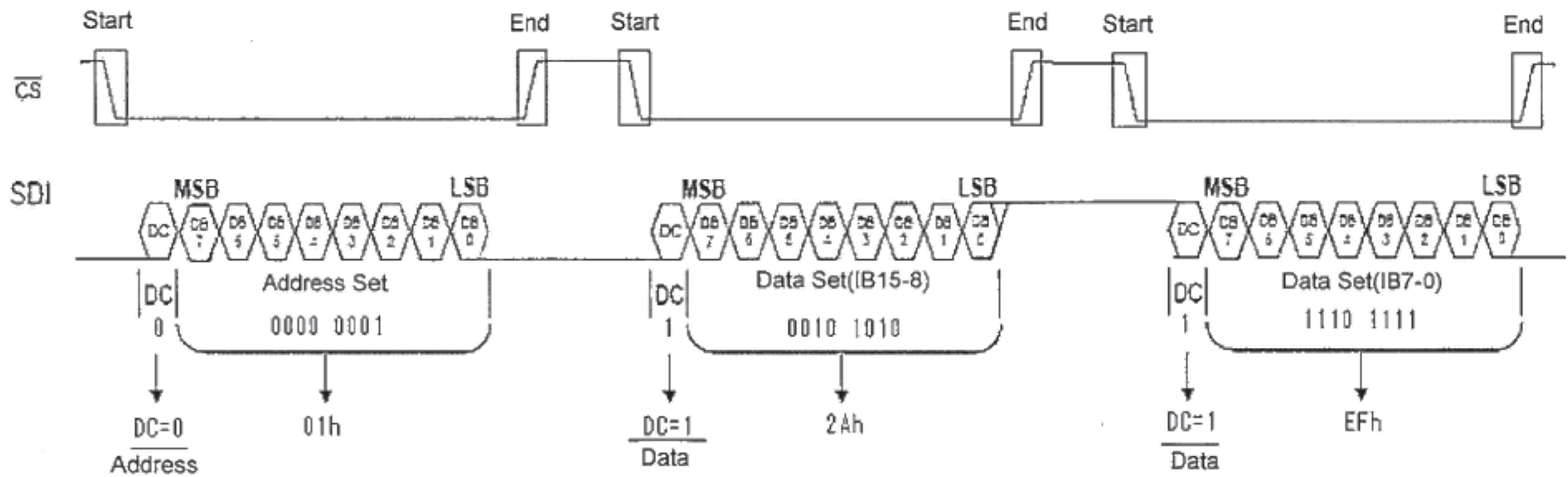

7-8. Input Data Signals and Display Position on the screen

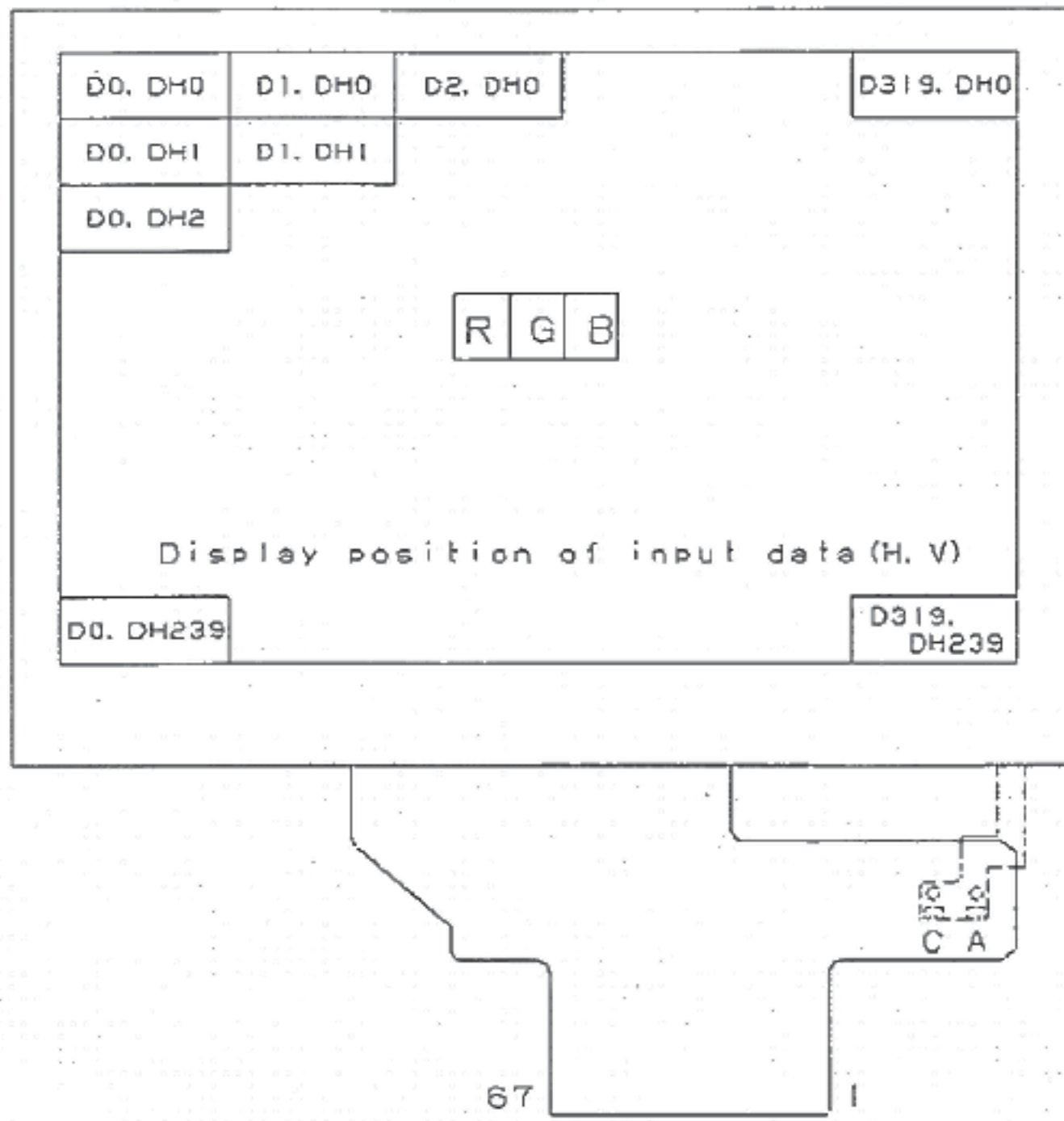

Please refer to Input Terminal Names and Functions

8. Input Signals, Basic Display Colors and Gray Scale of Each Color

	Colors & Gray Scale	Date signal																		
		Gray Scale	R0	R1	R2	R3	R4	R5	G0	G1	G2	G3	G4	G5	B0	B1	B2	B3	B4	B5
			LSB					MSB			LSB					MSB				
Basic Color	Black	—	0	0	0	0	0	0	0	0	0	0	0	0	0	0	0	0	0	0
	Blue	—	0	0	0	0	0	0	0	0	0	0	0	0	1	1	1	1	1	1
	Green	—	0	0	0	0	0	0	1	1	1	1	1	1	0	0	0	0	0	0
	Cyan	—	0	0	0	0	0	0	1	1	1	1	1	1	1	1	1	1	1	1
	Red	—	1	1	1	1	1	1	0	0	0	0	0	0	0	0	0	0	0	0
	Magenta	—	1	1	1	1	1	1	0	0	0	0	0	0	1	1	1	1	1	1
	Yellow	—	1	1	1	1	1	1	1	1	1	1	1	1	0	0	0	0	0	0
	White	—	1	1	1	1	1	1	1	1	1	1	1	1	1	1	1	1	1	1
Gray Scale of Red	Black	GS0	0	0	0	0	0	0	0	0	0	0	0	0	0	0	0	0	0	0
	↑	GS1	1	0	0	0	0	0	0	0	0	0	0	0	0	0	0	0	0	0
	Darker	GS2	0	1	0	0	0	0	0	0	0	0	0	0	0	0	0	0	0	0
	↑	↓	↓					↓					↓							
	↓	↓	↓					↓					↓							
	Brighter	GS61	1	0	1	1	1	1	0	0	0	0	0	0	0	0	0	0	0	0
	↓	GS62	0	1	1	1	1	1	0	0	0	0	0	0	0	0	0	0	0	0
	Red	GS63	1	1	1	1	1	1	0	0	0	0	0	0	0	0	0	0	0	0
Gray Scale of Green	Black	GS0	0	0	0	0	0	0	0	0	0	0	0	0	0	0	0	0	0	0
	↑	GS1	0	0	0	0	0	0	1	0	0	0	0	0	0	0	0	0	0	0
	Darker	GS2	0	0	0	0	0	0	0	1	0	0	0	0	0	0	0	0	0	0
	↑	↓	↓					↓					↓							
	↓	↓	↓					↓					↓							
	Brighter	GS61	0	0	0	0	0	0	1	0	1	1	1	1	0	0	0	0	0	0
	↓	GS62	0	0	0	0	0	0	0	1	1	1	1	1	0	0	0	0	0	0
	Green	GS63	0	0	0	0	0	0	1	1	1	1	1	1	0	0	0	0	0	0
Gray Scale of Blue	Black	GS0	0	0	0	0	0	0	0	0	0	0	0	0	0	0	0	0	0	0
	↑	GS1	0	0	0	0	0	0	0	0	0	0	0	0	1	0	0	0	0	0
	Darker	GS2	0	0	0	0	0	0	0	0	0	0	0	0	0	1	0	0	0	0
	↑	↓	↓					↓					↓							
	↓	↓	↓					↓					↓							
	Brighter	GS61	0	0	0	0	0	0	0	0	0	0	0	0	1	0	1	1	1	1
	↓	GS62	0	0	0	0	0	0	0	0	0	0	0	0	0	1	1	1	1	1
	Blue	GS63	0	0	0	0	0	0	0	0	0	0	0	0	1	1	1	1	1	1

0: Low level voltage, 1: High level voltage

Each basic color can be displayed in 64 gray scales from 6 bit data signals.
According to the combination of 18 bit data signals, the 262k color display can be achieved on the screen.

9. Optical Characteristics

Ta = 25°C, V_{DDIO} = +3.3V, V_{CI} = +3.3V

Parameter		Symbol	Condition	Min.	Typ.	Max.	Unit	Remark
Viewing angle range (With Wide View)	Horizontal	θ21	CR ≥ 10	-	(70)	-	deg.	【Note1,4】
		θ22		-	(70)	-	deg.	
	Vertical	θ11		-	(60)	-	deg.	
		θ12		-	(65)	-	deg.	
Contrast ratio		CR	Optimum viewing angle	100	300	-		【Note2,4】
Response Time	Rise	Tr	θ=0°	-	30	45	ms	【Note3,4】
	Decay	Td		-	30	45	ms	
Chromaticity of White		x		(0.26)	(0.31)	(0.36)		【Note4】
		y		(0.29)	(0.34)	(0.39)		
Luminance of white		XL1		(350)	(450)	-	cd/m ²	I _{LED} =20mA

* The optical characteristics measurements are operated under a stable luminescence (I_{LED} = 20mA) and a dark condition. (Refer to Fig.9-1,2)

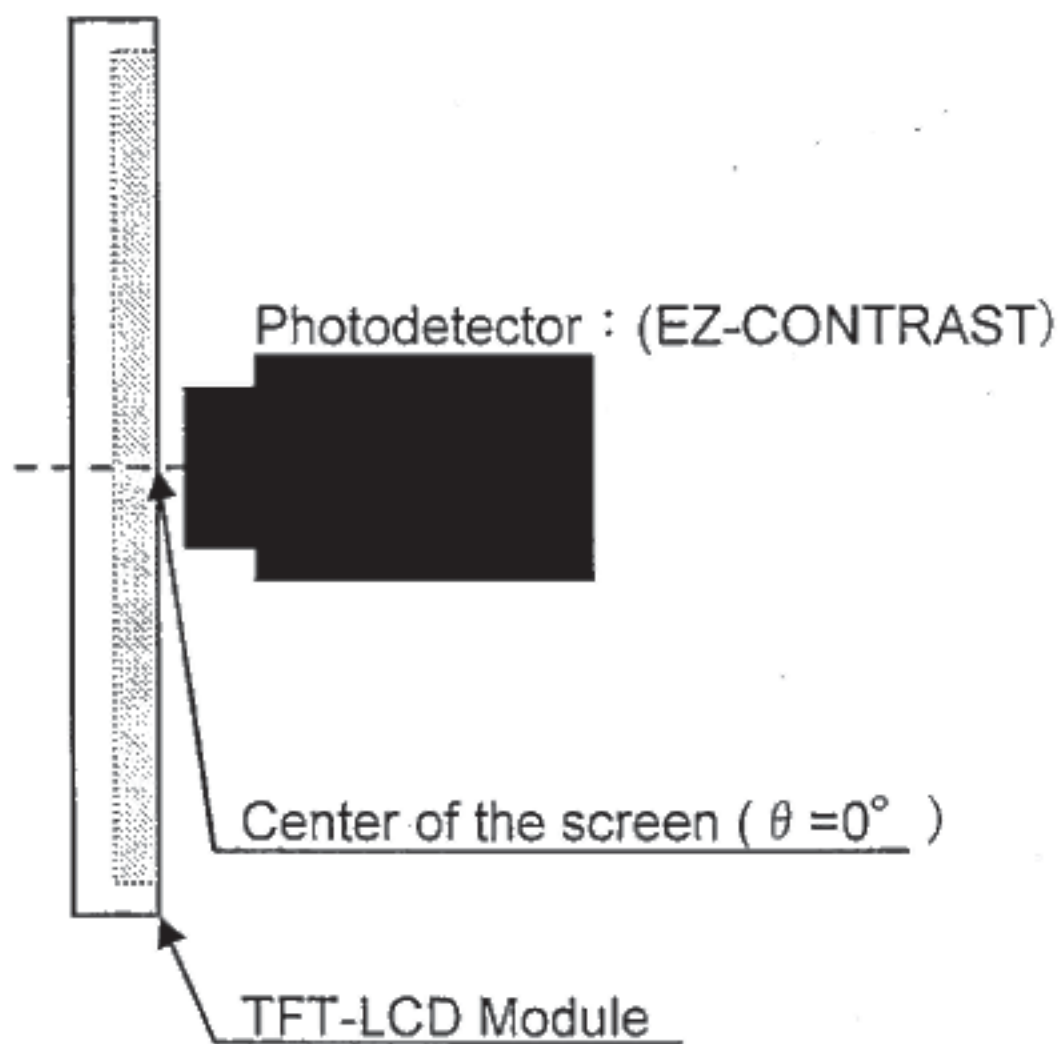

Fig.9-1 Measuring setup for Viewing angle and Contrast

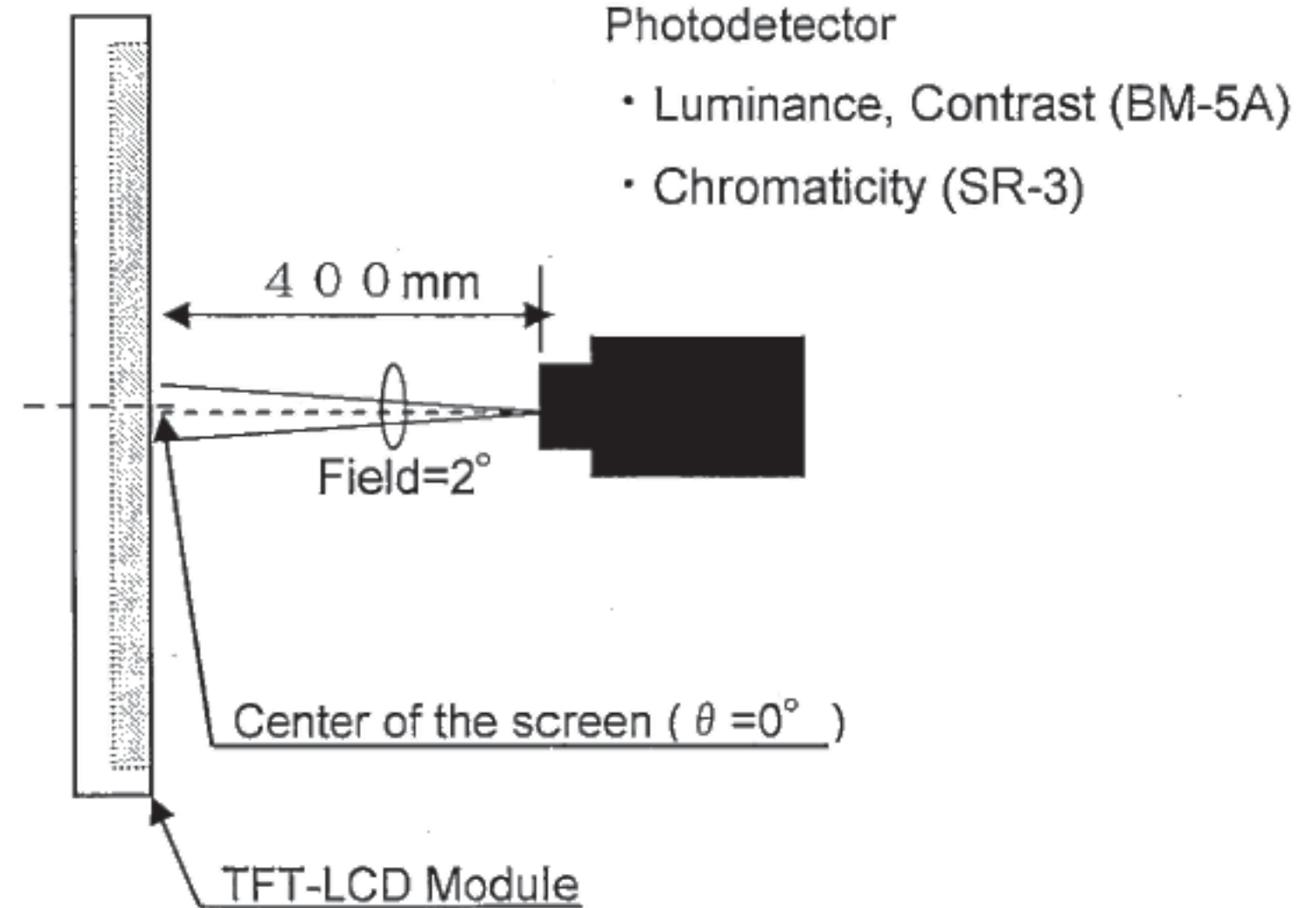
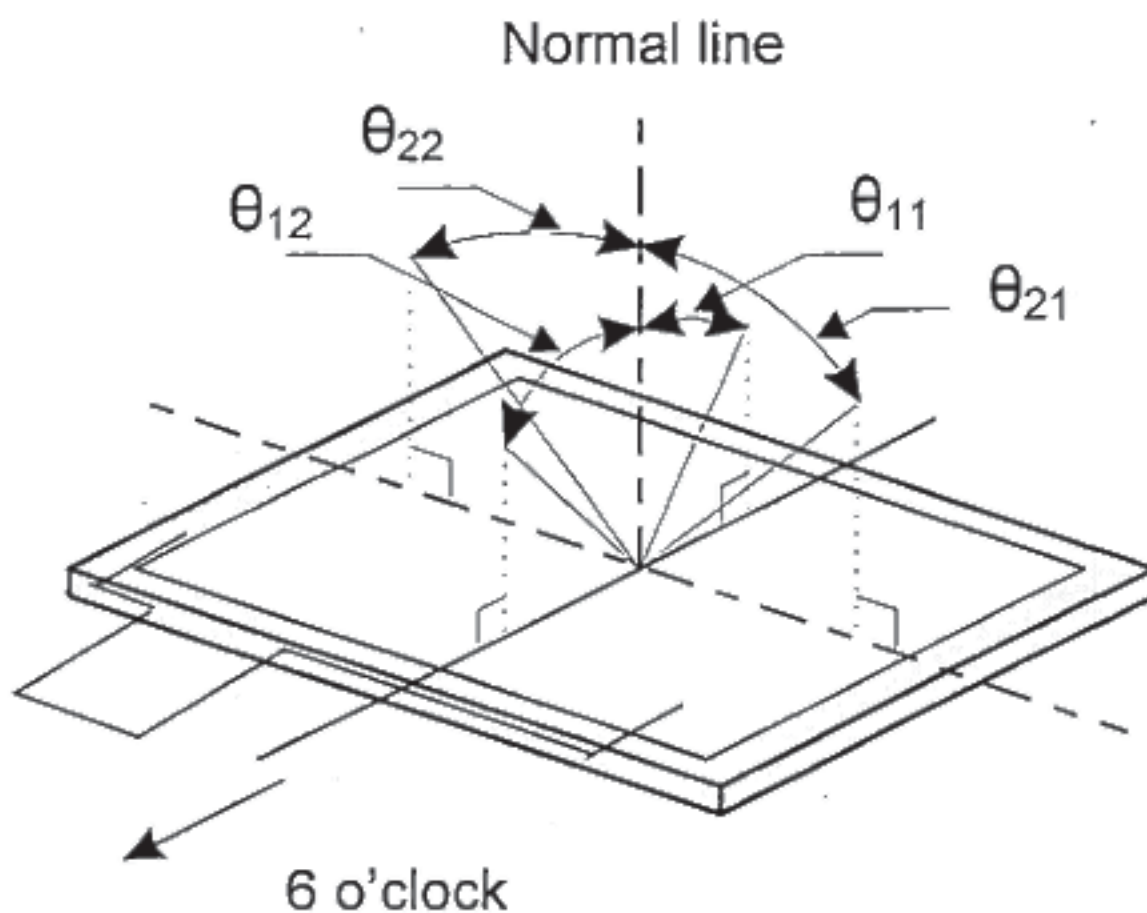

Fig.9-2 Measuring setup for Luminance, Chromaticity and Response time

【 Note 1 】 Definitions of viewing angle range



【 Note 2 】 Definition of contrast ratio

The contrast ratio is defined as the following

$$\text{Contrast ratio (CR)} = \frac{\text{Luminance (brightness) with all pixels white}}{\text{Luminance (brightness) with all pixels black}}$$

【 Note 3 】 Definition of response time

The response time is defined as the following figure and shall be measured by switching the input signal for "Black" and "White"

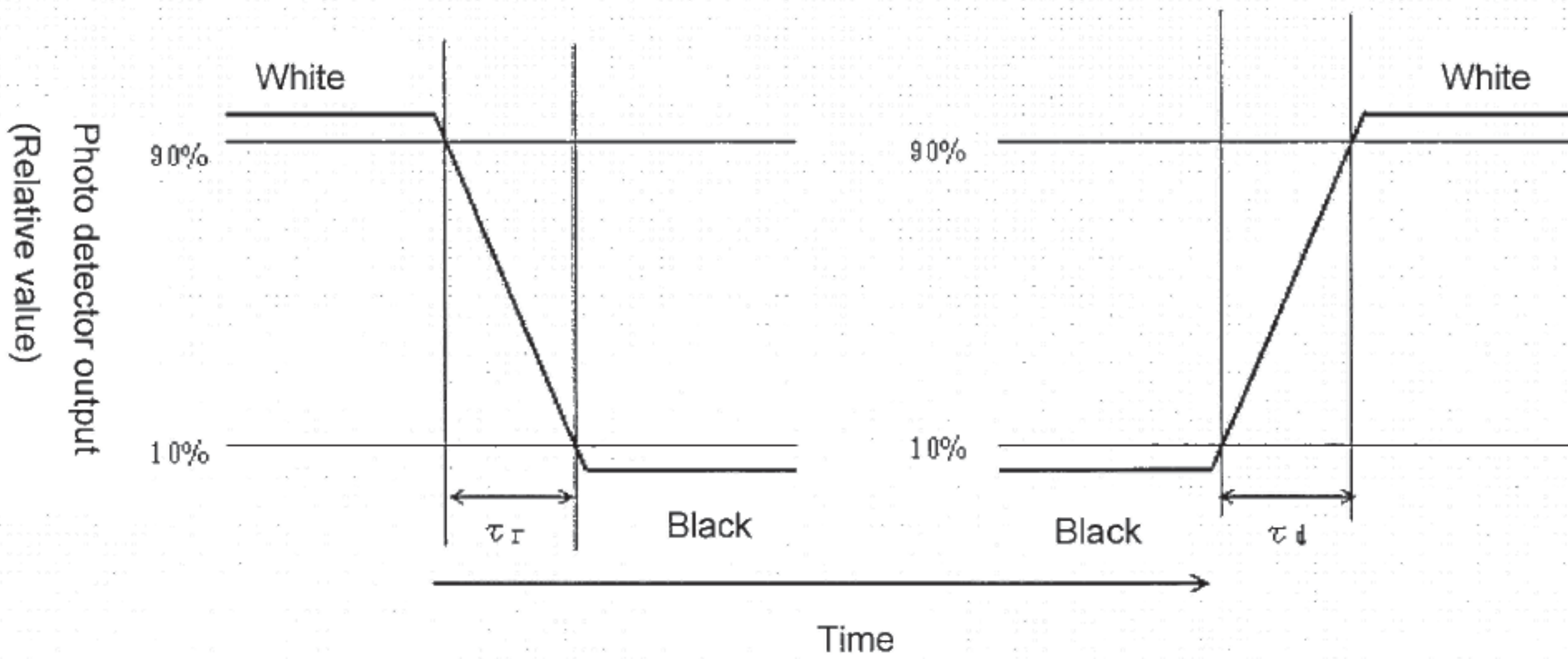

【 Note 4 】 This shall be measured at center of the screen.

10 Handling of modules

10-1. Inserting the FPC into its connector and pulling it out

- 1) Be sure to turn off the power supply and the signals when inserting or disconnecting the cable.
- 2) Please insert for too much stress not to join FPC in the case of insertion of FPC.

10-2. About handling of FPC

- 1) The bending radius of the FPC should be more than 1.4mm, and it should be bent evenly.
- 2) Do not dangle the LCD module by holding the FPC, or do not give any stress to it.

10-3. Mounting of the module

- 1) The module should be held on to the plain surface. Do not give any warping or twisting stress to the module.
- 2) Please consider that GND can ground a modular metal portion etc. so that static electricity is not charged to a module.

10-4. Cautions in assembly / Handling pre cautions

As the polarizer can be easily scratched, be most careful in handling it.

1) Work environments in assembly.

Since removing laminator may causes electrostatic charge that tends to attract dust, the following work environment would be desired.

- a) Floor: Conductive treatment having 1MΩ resistance onto floor's tile
- b) The room free from dust coming from outdoor environment, and put an adhesive mat at entrances.
- c) Humidity from 50% to 70% and temperature from 15°C to 27°C are desirable.
- d) Worker should ware conductive shoes, conductive fatigue, conductive glove and earth wrist band.

2) Instruction for working

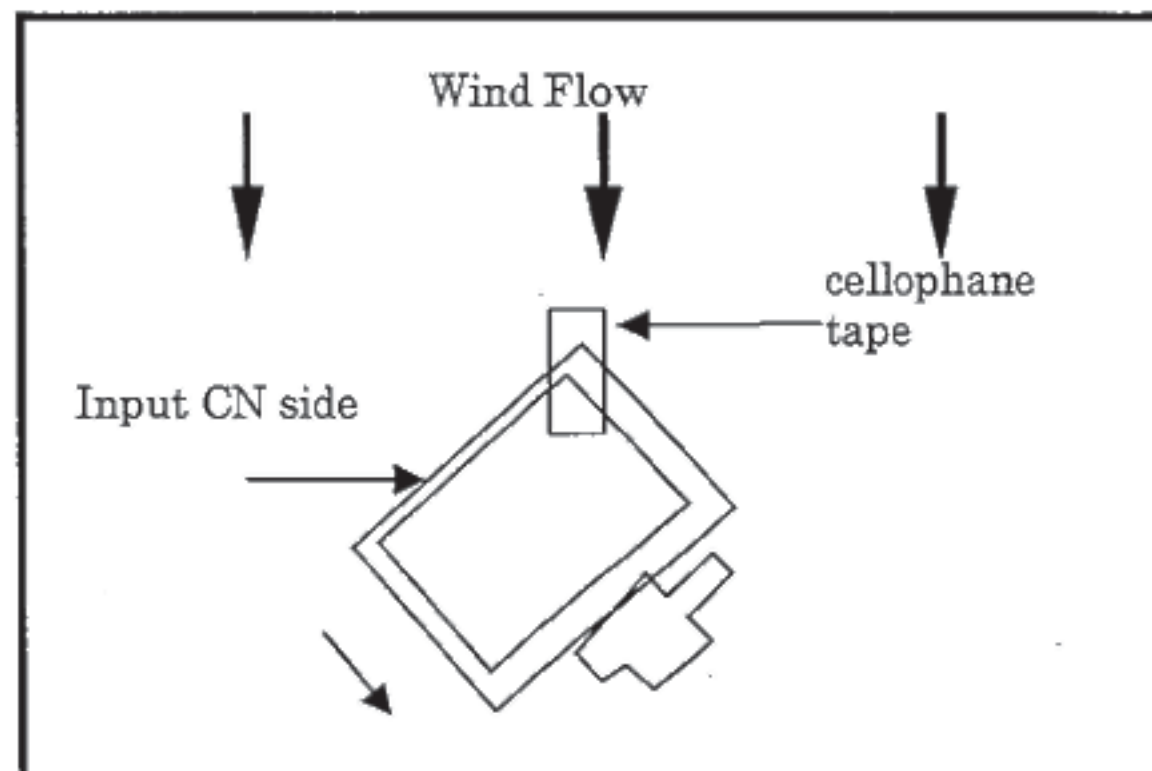
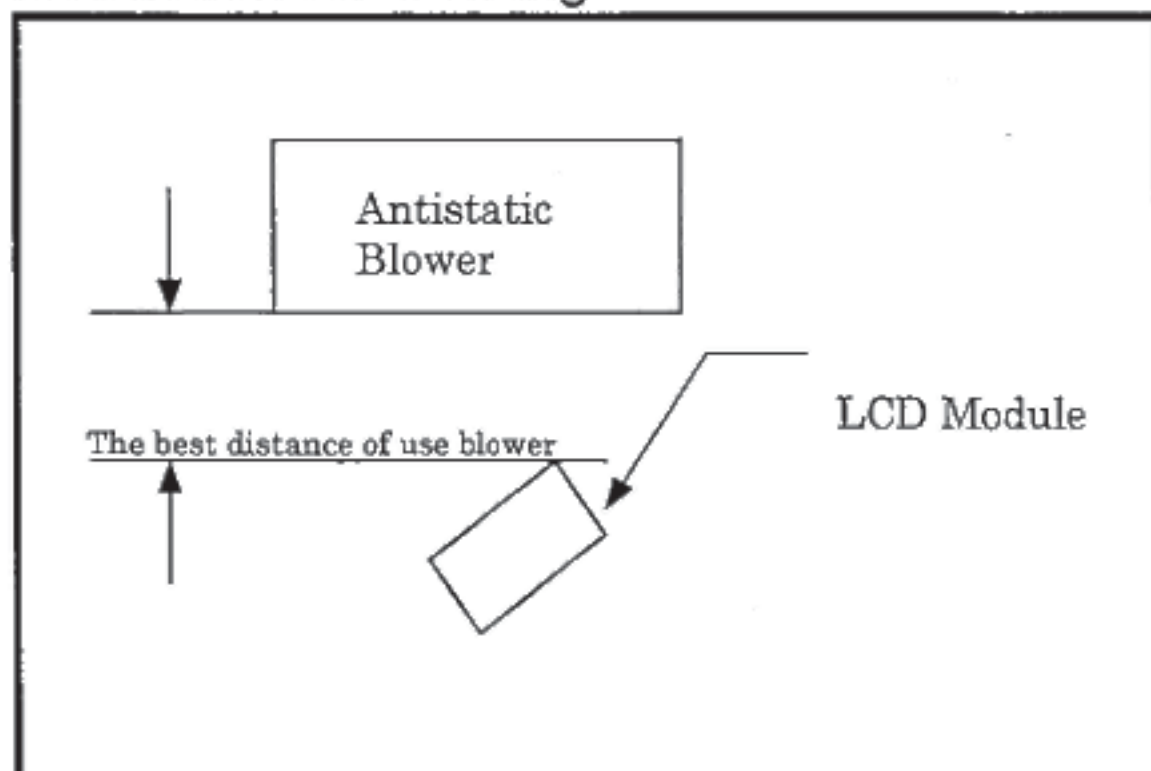

- a) Wind direction of an antistatic blower should slightly downward to properly blow the module. The distance between the blower and the module should be the best distance of use blower. Also, pay attention to the direction of the module.
- b) To prevent polarizer from scratching, adhesive tape (cellophane tape) should be stuck at the part of laminator sheet, which is closed to blower. [See the above]
- c) Pull slowly adhesive tape to peel the laminator off, with spending more than 5 second.
- d) The module without laminator should be moved to the next process to prevent adhesion of dust.

3) How to remove dust on the polarizer

- a) Blow out dust by the use of an N₂ blower with antistatic measures taken. Use of an ionized air Gun is recommendable.
 - b) When the panel surface is soiled, wipe it with soft cloth.
- 4) In the case of the module's metal part (shield case) is stained, wipe it with a piece of dry, soft cloth. If rather difficult, give a breath on the metal part to clean better.
- 5) If water dropped, etc. remains stuck on the polarizer for a long time, it is apt to get discolored or cause stains. Wipe it immediately.
- 6) As a glass substrate is used for the TFT-LCD panel, if it is dropped on the floor or hit by something hard, it may be broken or chipped off.
- 7) Since CMOS LSI is used in this module, take care of static electricity and take the human earth into consideration when handling.

10-5. Others

- 1) Regarding storage of LCD modules, avoid storing them at direct sunlight-situation.
- 2) If stored at temperatures below the rated values, the inner liquid crystal may freeze, causing cell destruction. At temperatures exceeding the rated values for storage, the liquid crystal may become isotropic liquid, making it no longer possible to come back to its original state in some cases.
- 3) If the LCD is broken, do not drink liquid crystal in the mouth. If the liquid crystal adheres to a hand or foot or to clothes, immediately cleanse it with soap.
- 4) If a water drop or dust adheres to the polarizer, it is apt to cause deterioration. Wipe it immediately.
- 5) Be sure to observe other caution items for ordinary electronic parts and components.

11. Reliability test items

No.	Test item	Conditions
1	High temperature storage test	Ta = 80°C 240h
2	Low temperature storage test	Ta = -30°C 240h
3	High temperature & high humidity operation test	Ta = 40°C ; 95%RH 240h (No condensation)
4	High temperature operation test	Ta =70°C 240h (The panel temp. must be less than 70°C(Tp))
5	Low temperature operation test	Ta = -20°C 240h
6	Vibration test (non- operating)	Frequency range: 10 to 55Hz Stroke: 1.5mm Sweep time: 1minutes Test period: 2 hours for each direction of X,Y,Z
7	Shock test	Direction: ±X, ±Y, ±Z, Time: Third for each direction. Impact value: 980m/s ² , Action time 6ms
8	Thermal shock test	Ta=-20°C to 70°C /10 cycles (30 min) (30min)

【Check items】

In the standard condition, there shall be no practical problems that may affect the display function.

12. Display Grade

The standard regarding the grade of color LCD displaying modules should be based on the delivery inspection standard.

13. Delivery Form

13-1. Carton storage conditions

1) Carton piling-up: Max 8 rows

2) Environments

Temperature: 0~40°C

Humidity: 65% RH or less (at 40°C)

There should be no dew condensation even at a low temperature and high humidity.

3) Packing form: 15. LCD module packing carton

※Cartons are weak against damp, and they are apt to be smashed easily due to the compressive pressure applied when piled up. The above environmental conditions of temperature and humidity are set in consideration of reasonable pile-up for storage.

14. Lot No. marking

The lot No. will be indicated on individual labels. The location is as shown

Indication Label

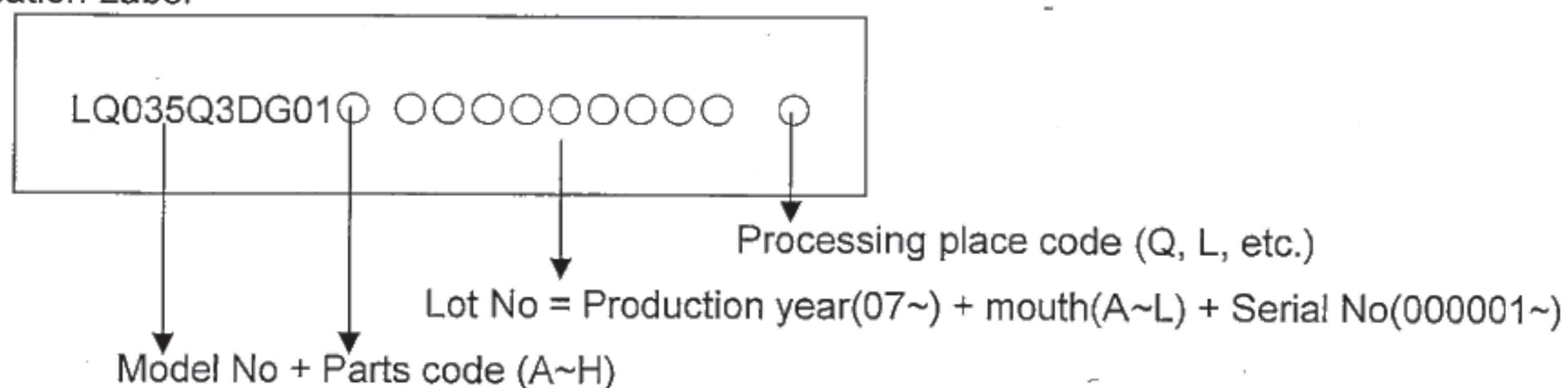

15. LCD module packing carton

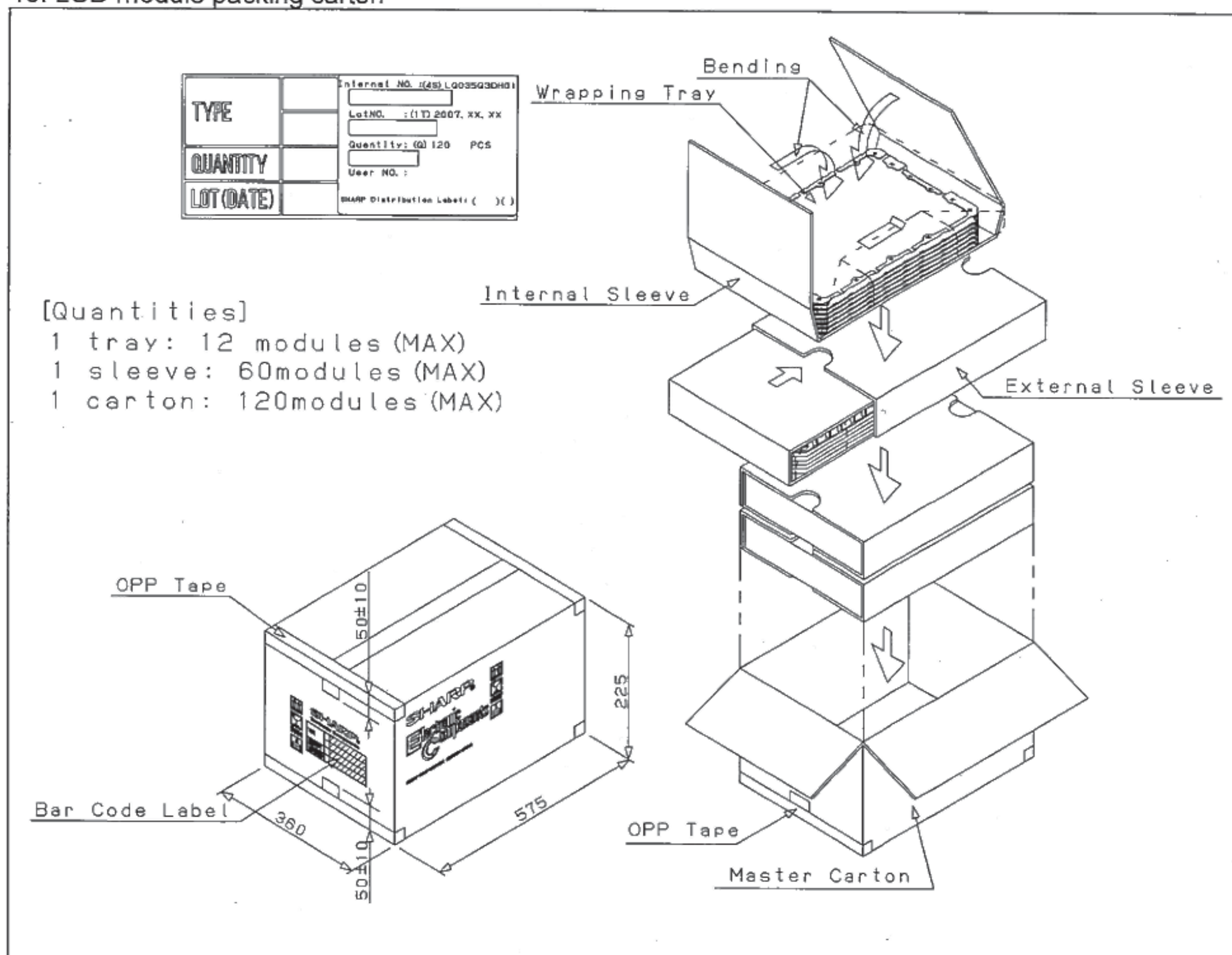

16. Others

- 1 Disassembling the module can cause permanent damage and you should be strictly avoided.
- 2 Please be careful that you don't keep the screen displayed fixed pattern image for a long time, since retention may occur.
- 3 If you pressed down a liquid crystal display screen with your finger and so on, the alignment disorder of liquid crystal will occur. And then It will become display fault.
Therefore, be careful not to touch the screen directly, and to consider not stressing to it.
- 4 If any problem arises regarding the items mentioned in this specification sheet or otherwise, it should be discussed and settled mutually in a good faith for remedy and/or improvement.

SHARP

Outline proposal

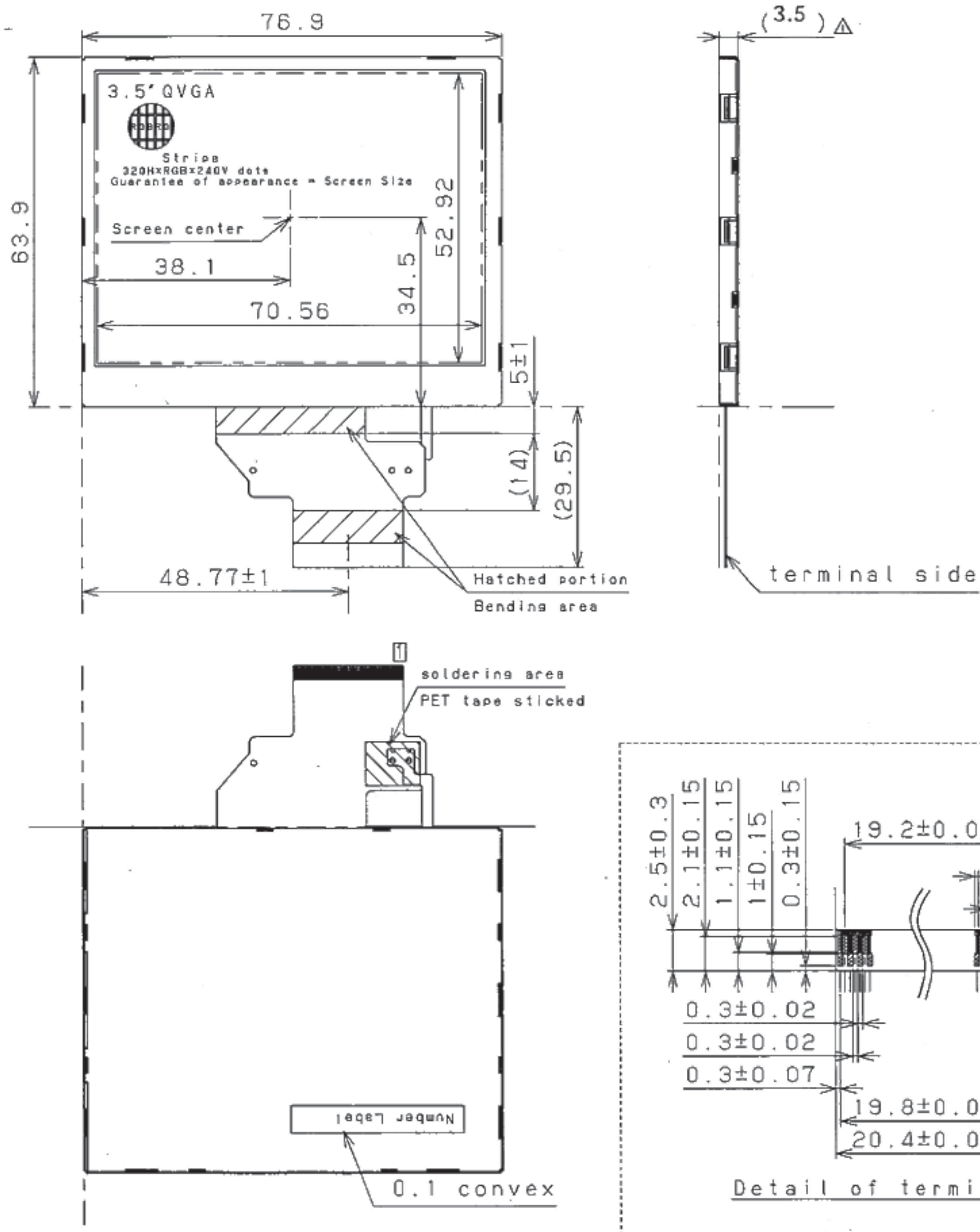

Fitting CN:HIROSE FH26G or ELC0 6281

- note1) General tolerance is ±0.5
- note2) Take care in set design to hide the scratches and bubbles appeared on the polarizer or other case area which is located outside of active area.
- note3) Any foreign materials and contamination outside Active Area are to be treated as "No-Count" at our inspections.
- note4) The light of Back Light is leaking from BM outside. Please light shielding by the set.
- note5) The tolerance of module width are exclude warp of case.
- note6) LCD-FPC bend larger than 0.6 in radius.

Since this module is under development, all the specified value is tentative. The technical literature is subject to change without notice.

unit:mm	Please do not copy this material and do not disclose this to third party.			
DATE	2007.04.03	SCALE	1/1	
MODEL	LQ035Q3DG01	No.	07.05.26	Change thickness
DRAWING NO	LCM1-0708B	size	A3	REVISION
			SHARP CO. LTD	MOBILE LCD 1 DESIGN CENTER ENGINEERING DEPT. IV