

# KOE

---

## JDI Group

Kaohsiung Opto-Electronics Inc.

FOR MESSRS : \_\_\_\_\_

DATE : Aug. 30<sup>th</sup> ,2016

### CUSTOMER'S ACCEPTANCE SPECIFICATIONS

### TX09D70VM1CCA

#### Contents

No.	ITEM	SHEET No.	PAGE
1	COVER	7B64PS 2701-TX09D70VM1CCA-11	1-1/1
2	RECORD OF REVISION	7B64PS 2702-TX09D70VM1CCA-11	2-1/4~4/4
3	GENERAL DATA	7B64PS 2703-TX09D70VM1CCA-11	3-1/1
4	ABSOLUTE MAXIMUM RATINGS	7B64PS 2704-TX09D70VM1CCA-11	4-1/1
5	ELECTRICAL CHARACTERISTICS	7B64PS 2705-TX09D70VM1CCA-11	5-1/1
6	OPTICAL CHARACTERISTICS	7B64PS 2706-TX09D70VM1CCA-11	6-1/2~2/2
7	BLOCK DIAGRAM	7B64PS 2707-TX09D70VM1CCA-11	7-1/1
8	RELIABILITY TESTS	7B64PS 2708-TX09D70VM1CCA-11	8-1/1
9	LCD INTERFACE	7B64PS 2709-TX09D70VM1CCA-11	9-1/6~6/6
10	OUTLINE DIMENSIONS	7B64PS 2710-TX09D70VM1CCA-11	10-1/1
11	TOUCH PANEL	7B64PS 2711-TX09D70VM1CCA-11	11-1/2~2/2
12	APPEARANCE STANDARD	7B64PS 2712-TX09D70VM1CCA-11	12-1/4~4/4
13	PRECAUTIONS	7B64PS 2713-TX09D70VM1CCA-11	13-1/2~2/2
14	DESIGNATION OF LOT MARK	7B64PS 2714-TX09D70VM1CCA-11	14-1/1

ACCEPTED BY : \_\_\_\_\_

PROPOSED BY: Oblack Tsai

# RECORD OF REVISION

DATE	SHEET No.	SUMMARY																																										
Oct.28,'05	7B64PS 2704- TX09D70VM1CCA-2 Page 4-1/2	<b>4.1 ELECTRICAL ABSOLUTE MAXIMUM RATINGS OF LCD</b> Revised																																										
		<table border="1" style="width: 100%; border-collapse: collapse;"> <thead> <tr> <th style="width: 10%;">ITEM</th> <th style="width: 60%;">SYMBOL</th> <th style="width: 30%;">MAX</th> </tr> </thead> <tbody> <tr> <td rowspan="2" style="text-align: center;">LED</td> <td>Forward Current</td> <td style="text-align: center;">IF</td> </tr> <tr> <td>Pulse Forward Current</td> <td style="text-align: center;">IFP</td> </tr> <tr> <td colspan="2"></td> <td style="text-align: center;">↓</td> </tr> <tr> <th style="width: 10%;">ITEM</th> <th style="width: 60%;">SYMBOL</th> <th style="width: 30%;">MAX</th> </tr> <tr> <td rowspan="2" style="text-align: center;">LED</td> <td>Forward Current</td> <td style="text-align: center;">IF</td> </tr> <tr> <td>Pulse Forward Current</td> <td style="text-align: center;">IFP</td> </tr> </tbody> </table>	ITEM	SYMBOL	MAX	LED	Forward Current	IF	Pulse Forward Current	IFP			↓	ITEM	SYMBOL	MAX	LED	Forward Current	IF	Pulse Forward Current	IFP																							
		ITEM	SYMBOL	MAX																																								
		LED	Forward Current	IF																																								
Pulse Forward Current	IFP																																											
		↓																																										
ITEM	SYMBOL	MAX																																										
LED	Forward Current	IF																																										
	Pulse Forward Current	IFP																																										
Note 4 :																																												
	7B64PS 2705- TX09D70VM1CCA-2 Page 5-1/2	<b>5.2 ELECTRICAL CHARACTERISTICS OF BACK LIGHT</b> Revised																																										
		<table border="1" style="width: 100%; border-collapse: collapse;"> <thead> <tr> <th style="width: 15%;">ITEM</th> <th style="width: 15%;">SYMBOL</th> <th style="width: 20%;">CONDITION</th> <th style="width: 10%;">MAX.</th> <th style="width: 10%;">TYP.</th> <th style="width: 10%;">MAX.</th> </tr> </thead> <tbody> <tr> <td>LED Input Voltage</td> <td style="text-align: center;">VF</td> <td style="text-align: center;">IF=20mA</td> <td style="text-align: center;">-</td> <td style="text-align: center;">3.75</td> <td style="text-align: center;">4.2</td> </tr> <tr> <td>LED Forward Current</td> <td style="text-align: center;">IF</td> <td style="text-align: center;">-</td> <td style="text-align: center;">-</td> <td style="text-align: center;">20</td> <td style="text-align: center;">20</td> </tr> <tr> <td colspan="6" style="text-align: center;">↓</td> </tr> <tr> <th style="width: 15%;">ITEM</th> <th style="width: 15%;">SYMBOL</th> <th style="width: 20%;">CONDITION</th> <th style="width: 10%;">MAX.</th> <th style="width: 10%;">TYP.</th> <th style="width: 10%;">MAX.</th> </tr> <tr> <td>LED Input Voltage</td> <td style="text-align: center;">VF</td> <td style="text-align: center;">IF=20mA</td> <td style="text-align: center;">-</td> <td style="text-align: center;">3.2</td> <td style="text-align: center;">3.5</td> </tr> <tr> <td>LED Forward Current</td> <td style="text-align: center;">IF</td> <td style="text-align: center;">-</td> <td style="text-align: center;">-</td> <td style="text-align: center;">20</td> <td style="text-align: center;">25</td> </tr> </tbody> </table>	ITEM	SYMBOL	CONDITION	MAX.	TYP.	MAX.	LED Input Voltage	VF	IF=20mA	-	3.75	4.2	LED Forward Current	IF	-	-	20	20	↓						ITEM	SYMBOL	CONDITION	MAX.	TYP.	MAX.	LED Input Voltage	VF	IF=20mA	-	3.2	3.5	LED Forward Current	IF	-	-	20	25
		ITEM	SYMBOL	CONDITION	MAX.	TYP.	MAX.																																					
		LED Input Voltage	VF	IF=20mA	-	3.75	4.2																																					
LED Forward Current	IF	-	-	20	20																																							
↓																																												
ITEM	SYMBOL	CONDITION	MAX.	TYP.	MAX.																																							
LED Input Voltage	VF	IF=20mA	-	3.2	3.5																																							
LED Forward Current	IF	-	-	20	25																																							
Note 5 :																																												
		<b>6.1 OPTICAL CHARACTERISTICS OF LCD</b> Revised the color tone																																										
		<b>8.5 INTERNAL PIN CONNECTION</b> Revised the function of PIN35 Added Note1																																										

# RECORD OF REVISION

DATE	SHEET No.	SUMMARY																				
Jan.27,'06	7B64PS 2708- TX09D70VM1CCA-3 Page 8-3/6	8.3 POWER ON/OFF SEQUENCE Added the waveform of PCI signal																				
	7B64PS 2708- TX09D70VM1CCA-3 Page 8-6/6	8.5 INTERNAL PIN CONNECTION Revised the function of PIN35 Revised Note1																				
Feb.17,'06	7B64PS 2708- TX09D70VM1CCA-4 Page 8-1/6	8.1 INTERFACE TIMING Revised <table style="margin-left: auto; margin-right: auto; border-collapse: collapse;"> <tr> <td style="border: 1px solid black; width: 150px; height: 15px;"></td> <td style="border: 1px solid black; width: 60px; text-align: center;">MIN</td> <td style="width: 20px;"></td> <td style="border: 1px solid black; width: 60px; text-align: center;">MIN</td> </tr> <tr> <td style="border: 1px solid black;">Horizontal Total</td> <td style="border: 1px solid black; text-align: center;">258</td> <td style="text-align: center;">→</td> <td style="border: 1px solid black; text-align: center;">265</td> </tr> <tr> <td style="border: 1px solid black;">Horizontal Sync Start</td> <td style="border: 1px solid black; text-align: center;">246</td> <td></td> <td style="border: 1px solid black; text-align: center;">244</td> </tr> <tr> <td style="border: 1px solid black;">Horizontal Sync End</td> <td style="border: 1px solid black; text-align: center;">250</td> <td></td> <td style="border: 1px solid black; text-align: center;">248</td> </tr> <tr> <td style="border: 1px solid black;">Horizontal Blank Time</td> <td style="border: 1px solid black; text-align: center;">18</td> <td></td> <td style="border: 1px solid black; text-align: center;">25</td> </tr> </table>		MIN		MIN	Horizontal Total	258	→	265	Horizontal Sync Start	246		244	Horizontal Sync End	250		248	Horizontal Blank Time	18		25
	MIN		MIN																			
Horizontal Total	258	→	265																			
Horizontal Sync Start	246		244																			
Horizontal Sync End	250		248																			
Horizontal Blank Time	18		25																			
May.13,'08	7B64PS 2712- TX09D70VM1CCA-5 Page 12-1/1	12.1 LOT MARK Changed : 5 digits for production number ↓ 6 digits for production number  12.2 Location of lot mark Lot mark change: to Barcode label																				
Sep.23,'08	7B64PS 2708- TX09D70VM1CCA – 6 Page 8-6/6	8.5 INTERNAL PIN CONNECTION Revised CN1 tyco:1770046-3 (Suitable FPC : t0.3±0.03mm , 0.5±0.03mm pitch) ↓ CN1 : FA5S040HP1R3000 (Suitable FPC : t0.3±0.03mm , 0.5±0.03mm pitch)																				
	7B64PS 2712 – TX09D70VM1CCA – 6 Page 12 - 1/1	12. DESIGNATION OF LOT MARK Revised REV.A to REV.B																				
Jan.18,'11	7B64PS 2712 – TX09D70VM1CCA-7 Page 12 – 1/1	12.3 REVISION (REV.) CONTROL Added <table style="margin-left: auto; margin-right: auto; border-collapse: collapse;"> <tr> <td style="border: 1px solid black; width: 80px; text-align: center;">REV No.</td> <td style="border: 1px solid black; width: 150px; text-align: center;">ITEM</td> <td style="border: 1px solid black; width: 100px; text-align: center;">NOTE</td> </tr> <tr> <td style="border: 1px solid black; text-align: center;">C</td> <td style="border: 1px solid black; text-align: center;">Connectors Changed</td> <td style="border: 1px solid black; text-align: center;">PCN0804</td> </tr> </table>	REV No.	ITEM	NOTE	C	Connectors Changed	PCN0804														
REV No.	ITEM	NOTE																				
C	Connectors Changed	PCN0804																				
May 01,'12	All pages	Company name changed: KAOHSIUNG HITACHI ELECTRONICS CO.,LTD. ↓ KAOHSIUNG OPTO-ELECTRONICS INC.																				

# RECORD OF REVISION

DATE	SHEET No.	SUMMARY																																																																		
Nov.06,'12	7B64PS 2705- TX09D70VM1CCA-9 Page 5-2/2	5.3 ELECTRICAL CHARACTERISTICS OF TOUCH PANEL Revised Note (4) dimension 1mm → 2mm																																																																		
	7B64PS 2712- TX09D70VM1CCA-9 Page 12-1/1	12.3 REVISION (REV.) CONTROL Added <table border="1" style="margin-left: auto; margin-right: auto; border-collapse: collapse;"> <thead> <tr> <th style="width: 15%;">REV No.</th> <th style="width: 45%;">ITEM</th> <th style="width: 40%;">NOTE</th> </tr> </thead> <tbody> <tr> <td style="text-align: center;">D</td> <td>Film of TP changed</td> <td style="text-align: center;">PCN0852</td> </tr> </tbody> </table>	REV No.	ITEM	NOTE	D	Film of TP changed	PCN0852																																																												
REV No.	ITEM	NOTE																																																																		
D	Film of TP changed	PCN0852																																																																		
Jun.18,'14	7B64PS 2706 – TX09D70VM1CCA-10 Page 6-1/2	6.1 OPTICAL CHARACTERISTICS OF LCD (BACK LIGHT ON ) Revised:																																																																		
		<table border="1" style="width: 100%; border-collapse: collapse;"> <thead> <tr> <th colspan="2">ITEM</th> <th>MIN.</th> <th>TYP.</th> <th>MAX.</th> </tr> </thead> <tbody> <tr> <td rowspan="6" style="text-align: center; vertical-align: middle;">Color Tone (Primary Color)</td> <td rowspan="2" style="text-align: center; vertical-align: middle;">Red</td> <td style="text-align: center;">0.55</td> <td style="text-align: center;">0.60</td> <td style="text-align: center;">0.65</td> </tr> <tr> <td style="text-align: center;">0.29</td> <td style="text-align: center;">0.34</td> <td style="text-align: center;">0.39</td> </tr> <tr> <td rowspan="2" style="text-align: center; vertical-align: middle;">Green</td> <td style="text-align: center;">0.28</td> <td style="text-align: center;">0.33</td> <td style="text-align: center;">0.38</td> </tr> <tr> <td style="text-align: center;">0.54</td> <td style="text-align: center;">0.59</td> <td style="text-align: center;">0.64</td> </tr> <tr> <td rowspan="2" style="text-align: center; vertical-align: middle;">Blue</td> <td style="text-align: center;">0.09</td> <td style="text-align: center;">0.14</td> <td style="text-align: center;">0.19</td> </tr> <tr> <td style="text-align: center;">0.07</td> <td style="text-align: center;">0.12</td> <td style="text-align: center;">0.17</td> </tr> <tr> <td rowspan="2" style="text-align: center; vertical-align: middle;">White</td> <td style="text-align: center;">0.27</td> <td style="text-align: center;">0.32</td> <td style="text-align: center;">0.37</td> </tr> <tr> <td style="text-align: center;">0.29</td> <td style="text-align: center;">0.34</td> <td style="text-align: center;">0.39</td> </tr> </tbody> </table> <p style="text-align: center;">↓</p> <table border="1" style="width: 100%; border-collapse: collapse;"> <thead> <tr> <th colspan="2">ITEM</th> <th>MIN.</th> <th>TYP.</th> <th>MAX.</th> </tr> </thead> <tbody> <tr> <td rowspan="6" style="text-align: center; vertical-align: middle;">Color Tone (Primary Color)</td> <td rowspan="2" style="text-align: center; vertical-align: middle;">Red</td> <td style="text-align: center;">0.58</td> <td style="text-align: center;">0.63</td> <td style="text-align: center;">0.68</td> </tr> <tr> <td style="text-align: center;">0.28</td> <td style="text-align: center;">0.33</td> <td style="text-align: center;">0.38</td> </tr> <tr> <td rowspan="2" style="text-align: center; vertical-align: middle;">Green</td> <td style="text-align: center;">0.29</td> <td style="text-align: center;">0.34</td> <td style="text-align: center;">0.39</td> </tr> <tr> <td style="text-align: center;">0.54</td> <td style="text-align: center;">0.59</td> <td style="text-align: center;">0.64</td> </tr> <tr> <td rowspan="2" style="text-align: center; vertical-align: middle;">Blue</td> <td style="text-align: center;">0.10</td> <td style="text-align: center;">0.15</td> <td style="text-align: center;">0.20</td> </tr> <tr> <td style="text-align: center;">0.06</td> <td style="text-align: center;">0.11</td> <td style="text-align: center;">0.16</td> </tr> <tr> <td rowspan="2" style="text-align: center; vertical-align: middle;">White</td> <td style="text-align: center;">0.25</td> <td style="text-align: center;">0.30</td> <td style="text-align: center;">0.35</td> </tr> <tr> <td style="text-align: center;">0.27</td> <td style="text-align: center;">0.32</td> <td style="text-align: center;">0.37</td> </tr> </tbody> </table>	ITEM		MIN.	TYP.	MAX.	Color Tone (Primary Color)	Red	0.55	0.60	0.65	0.29	0.34	0.39	Green	0.28	0.33	0.38	0.54	0.59	0.64	Blue	0.09	0.14	0.19	0.07	0.12	0.17	White	0.27	0.32	0.37	0.29	0.34	0.39	ITEM		MIN.	TYP.	MAX.	Color Tone (Primary Color)	Red	0.58	0.63	0.68	0.28	0.33	0.38	Green	0.29	0.34	0.39	0.54	0.59	0.64	Blue	0.10	0.15	0.20	0.06	0.11	0.16	White	0.25	0.30	0.35	0.27
ITEM		MIN.	TYP.	MAX.																																																																
Color Tone (Primary Color)	Red	0.55	0.60	0.65																																																																
		0.29	0.34	0.39																																																																
	Green	0.28	0.33	0.38																																																																
		0.54	0.59	0.64																																																																
	Blue	0.09	0.14	0.19																																																																
		0.07	0.12	0.17																																																																
White	0.27	0.32	0.37																																																																	
	0.29	0.34	0.39																																																																	
ITEM		MIN.	TYP.	MAX.																																																																
Color Tone (Primary Color)	Red	0.58	0.63	0.68																																																																
		0.28	0.33	0.38																																																																
	Green	0.29	0.34	0.39																																																																
		0.54	0.59	0.64																																																																
	Blue	0.10	0.15	0.20																																																																
		0.06	0.11	0.16																																																																
White	0.25	0.30	0.35																																																																	
	0.27	0.32	0.37																																																																	
7B64PS 2714 – TX09D70VM1CCA-10 Page 14-1/1	14.2 REVISION (REV.) CONTROL Added: <table border="1" style="margin-left: auto; margin-right: auto; border-collapse: collapse;"> <thead> <tr> <th style="width: 15%;">REV No.</th> <th style="width: 45%;">ITEM</th> <th style="width: 40%;">NOTE</th> </tr> </thead> <tbody> <tr> <td style="text-align: center;">E</td> <td>LCD Production Line Changed.</td> <td style="text-align: center;">PCN0885</td> </tr> </tbody> </table>	REV No.	ITEM	NOTE	E	LCD Production Line Changed.	PCN0885																																																													
REV No.	ITEM	NOTE																																																																		
E	LCD Production Line Changed.	PCN0885																																																																		

# RECORD OF REVISION

DATE	SHEET No.	SUMMARY																																
Aug.30,'16	7B64PS 2703- TX09D70VM1CCA-11 Page 3-1/1	3.1 DISPLAY FEATURES Revised : Power Consumption 0.66W → 0.42W																																
	7B64PS 2704- TX09D70VM1CCA-11 Page 4-1/1	4. ABSOLUTE MAXIMUM RATINGS Revised : LED Backlight Forward Current IF=35mA → 30mA Revised : Fig 4.1、Fig 4.2																																
	7B64PS 2705- TX09D70VM1CCA-11 Page 5-1/1	5.1 LCD CHARACTERISTICS Revised : Power Supply Current Typ. 200 → 125  5.2 BACKLIGHT CHARACTERISTICS Revised : <table border="1" style="width: 100%; border-collapse: collapse; margin: 5px 0;"> <thead> <tr> <th style="width: 30%;">Item</th> <th style="width: 30%;">Condition</th> <th style="width: 10%;">Typ.</th> <th style="width: 10%;">Max.</th> </tr> </thead> <tbody> <tr> <td>LED Input Voltage</td> <td>IF=20mA</td> <td style="text-align: center;">3.2</td> <td style="text-align: center;">3.5</td> </tr> <tr> <td>LED Forward Current</td> <td style="text-align: center;">-</td> <td style="text-align: center;">20</td> <td style="text-align: center;">25</td> </tr> <tr> <td>LED Reverse Current</td> <td>VR=5V</td> <td style="text-align: center;">-</td> <td style="text-align: center;">50</td> </tr> </tbody> </table> <div style="text-align: center; margin: 5px 0;">↓</div> <table border="1" style="width: 100%; border-collapse: collapse; margin: 5px 0;"> <thead> <tr> <th style="width: 30%;">Item</th> <th style="width: 30%;">Condition</th> <th style="width: 10%;">Typ.</th> <th style="width: 10%;">Max.</th> </tr> </thead> <tbody> <tr> <td>LED Input Voltage</td> <td>IF=15.4mA</td> <td style="text-align: center;">3.0</td> <td style="text-align: center;">3.2</td> </tr> <tr> <td>LED Forward Current</td> <td style="text-align: center;">-</td> <td style="text-align: center;">15.4</td> <td style="text-align: center;">25</td> </tr> <tr> <td>LED Reverse Current</td> <td>VR=5V</td> <td style="text-align: center;">-</td> <td style="text-align: center;">10</td> </tr> </tbody> </table>	Item	Condition	Typ.	Max.	LED Input Voltage	IF=20mA	3.2	3.5	LED Forward Current	-	20	25	LED Reverse Current	VR=5V	-	50	Item	Condition	Typ.	Max.	LED Input Voltage	IF=15.4mA	3.0	3.2	LED Forward Current	-	15.4	25	LED Reverse Current	VR=5V	-	10
	Item	Condition	Typ.	Max.																														
	LED Input Voltage	IF=20mA	3.2	3.5																														
	LED Forward Current	-	20	25																														
LED Reverse Current	VR=5V	-	50																															
Item	Condition	Typ.	Max.																															
LED Input Voltage	IF=15.4mA	3.0	3.2																															
LED Forward Current	-	15.4	25																															
LED Reverse Current	VR=5V	-	10																															
7B64PS 2706- TX09D70VM1CCA-11 Page 6-1/2	6. OPTICAL CHARACTERISTICS Revised : Condition 20 mA/per LED → 15.4mA/per LED																																	
7B64PS 2711- TX09D70VM1CCA-11 Page 11-1/2	11.2 ELECTRICAL CHARACTERISTICS Revised : XR-XL : 200~650Ω → 100~750Ω YU-YL : 250~500Ω → 310~950Ω																																	
7B64PS 2711- TX09D70VM1CCA-11 Page 11-2/2	11.3 MECHANICAL CHARACTERISTICS Revised : Surface Hardness JIS K 5400 → JIS K-5600-5-4																																	

### 3. GENERAL DATA

#### 3.1 DISPLAY FEATURES

This module is a 3.5" QVGA TFT with 3 by 4 format, which is composed of amorphous silicon. Each sub-pixel (dot) on the LCD is vertical stripe type arranged as R (red), G (green), B (blue) color sequentially. The bounding technology, COG (chip on glass), and LED backlight design have been applied on this display RoHS compliant.

Part Name	TX09D70VM1CCA
Module Dimensions	64.0(W) mm x 86.0(H) mm x 8.05(D) mm
LCD Active Area	53.64(W) mm x 71.52(H) mm
Pixel Pitch	0.2235(W) mm x 0.2235(H) mm
Resolution	240 x 3(RGB)(W) x 320(H) dots
Color Pixel Arrangement	R, G, B Vertical stripe
LCD Type	Transmissive Color TFT; Normally White
Display Type	Active Matrix
Number of Colors	262k Colors (6-bit RGB)
Backlight	Light Emitting Diode (LED)
Weight	48g
Interface	C-MOS; 40 pins
Power Supply Voltage	3.3V (Including LCD ,Timing Controller and Backlight)
Power Consumption	0.42W
Viewing Direction	6 O'clock (without image inversion and least brightness change) 12 O'clock (contrast peak located at)
Touch Panel	Resistance type. The surface is anti-glare.

## 4. ABSOLUTE MAXIMUM RATINGS

Item	Symbol	Min.	Max.	Unit	Remarks	
Supply Voltage	$V_{DD}$	-0.3	4.0	V	-	
Input Voltage of Logic	$V_I$	-0.3	$V_{DD}+0.3$	V	Note 1	
Operating Temperature	$T_{op}$	-20	70	°C	Note 2	
Storage Temperature	$T_{st}$	-30	80	°C	Note 2	
LED Backlight	Forward Current	$I_F$	-	30	mA	Note 3
	Pulse Forward Current	$I_{FP}$	-	100	mA	Note 4
	Reverse Voltage	$V_R$	-	5	V	LED unit

Note 1: The rating is defined for the signal voltages of the interface such as DTMG, DCLK and RGB data bus.

Note 2: The maximum rating is defined as above based on the chamber temperature, which might be different from ambient temperature after assembling the panel into the application. Moreover, some temperature-related phenomenon as below needed to be noticed:

- Background color, contrast and response time would be different from 25°C.
- Operating under high temperature will shorten LED lifetime.

Note 3: Fig. 4.1 shows the maximum rating of forward current based on different temperature for LED unit.

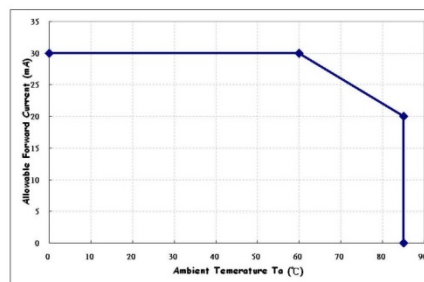

Fig. 4.1

Note 4: Fig. 4.2 shows the LED characteristics of the relationship between  $I_{FP}$  v.s. duty ratio, which is related to dimming control of LED backlight.

$I_{FP}$  condition :  
 pulse width  $\leq$  10ms  
 duty  $\leq$  1/10

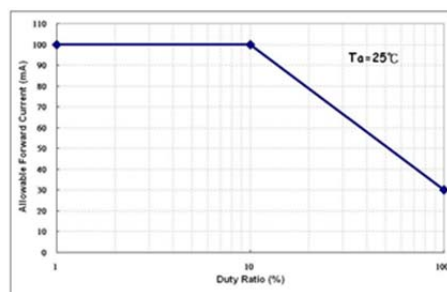

Fig. 4.2

# 5. ELECTRICAL CHARACTERISTICS

## 5.1 LCD CHARACTERISTICS

$T_a = 25\text{ }^\circ\text{C}$ ,  $V_{SS} = 0\text{V}$

Item	Symbol	Condition	Min.	Typ.	Max.	Unit	Remarks
Power Supply Voltage	$V_{DD}$	-	3.0	3.3	3.6	V	-
Input Voltage of Logic	$V_I$	"H" level	1.7	-	$V_{DD}$	V	Note 1
		"L" level	$V_{SS}$	-	0.7		
Power Supply Current	$I_{DD}$	$V_{DD}-V_{SS}=3.0\text{V}$	-	125	-	mA	Note 2,3
Frame Frequency	$f_{Frame}$	-	-	60	68	Hz	-
DCLK Frequency	$f_{CLK}$	-	4.62	5.33	6.04	MHz	

Note 1: The rating is defined for the signal voltages of the interface such as DTMG, DCLK and RGB data bus.

Note 2: An all black check pattern is used when measuring  $I_{DD}$ .  $f_{Frame}$  is set to 60Hz.

Note 3: 0.4A fuse is applied in the module for  $I_{DD}$ . For display activation and protection purpose, power supply is recommended larger than 1.0A to start the display and break fuse once any short circuit occurred.

## 5.2 BACKLIGHT CHARACTERISTICS

$T_a = 25\text{ }^\circ\text{C}$

Item	Symbol	Condition	Min.	Typ.	Max.	Unit	Remarks
LED Input Voltage	$V_F$	$I_F=15.4\text{mA}$	-	3.0	3.2	V	LED/Part
LED Forward Current	$I_F$	-	-	15.4	25	mA	LED/Part
LED Reverse Current	$I_R$	$V_R=5\text{V}$	-	-	10	$\mu\text{A}$	LED/Part
LED Current Control	Vctrl	$V_{DD}-V_{SS}=3.3\text{V}$	0	1.8	4.0	V	Note 1,2

Note 1: As Fig. 5.1 shown, LED current is controlled by the LED driver when applying 3.3V.

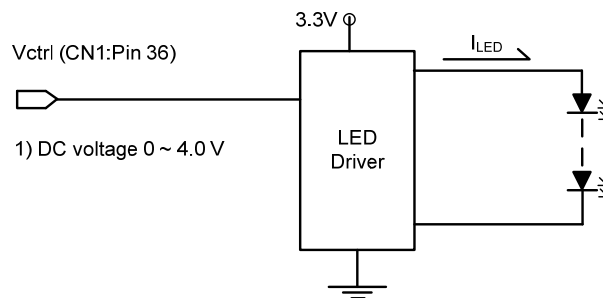
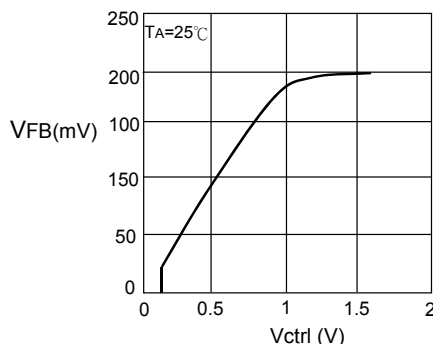

Fig 5.1

Note 2: LED current depend on following conditions.

LED current is calculated by Vctrl and  $V_{FB}$  when  $V_{FB}$  is controlled by Vctrl.



$$I_{LED} : \frac{V_{FB}}{10} : \text{When } V_{ctrl} > 1.8\text{ V}$$

$$I_{LED} : \frac{V_{ctrl}}{50} : \text{When } V_{ctrl} < 1\text{ V.}$$



## 6. OPTICAL CHARACTERISTICS

The optical characteristics are measured based on the conditions as below:

- Supplying the signals and voltages defined in the section of electrical characteristics.
- The backlight unit needs to be turned on after 30 minutes.
- The ambient temperature is 25 °C.
- In the dark room less than 100 lx, the equipment has been set for the measurements as shown in Fig 6.1.

$$T_a = 25\text{ }^\circ\text{C}, f_{Frame} = 60\text{ Hz}, V_{DD} = 3.3\text{V}$$

Item	Symbol	Condition	Min.	Typ.	Max.	Unit	Remarks
Brightness of White	B	$\phi = 0^\circ, \theta = 0^\circ$ 15.4 mA/per LED	270	320	-	cd/m <sup>2</sup>	Note 1
Brightness Uniformity	-		70	-	-	%	Note 2
Contrast Ratio	CR		180	300	-	-	Note 3
Response Time	Tr+Tf	$\phi = 0^\circ, \theta = 0$	-	30	-	ms	Note 4
Viewing Angle	$\theta = X$	$\phi = 0^\circ, CR \geq 10$	-	70	-	Degree	Note 5
	$\theta = X'$	$\phi = 180^\circ, CR \geq 10$	-	70	-		
	$\theta = Y$	$\phi = 90^\circ, CR \geq 10$	-	80	-		
	$\theta = Y'$	$\phi = 270^\circ, CR \geq 10$	-	60	-		
Color Chromaticity	Red	X	0.58	0.63	0.68	-	Note 6
		Y	0.28	0.33	0.38		
	Green	X	0.29	0.34	0.39		
		Y	0.54	0.59	0.64		
	Blue	X	0.10	0.15	0.20		
		Y	0.06	0.11	0.16		
	White	X	0.25	0.30	0.35		
		Y	0.27	0.32	0.37		

Note 1: The brightness is measured from the center point of the panel, P5 in Fig. 6.2, for the typical value.

Note 2: The brightness uniformity is calculated by the equation as below:

$$\text{Brightness uniformity} = \frac{\text{Min. Brightness}}{\text{Max. Brightness}} \times 100\%$$

which is based on the brightness values of the 9 points measured by BM-5 as shown in Fig. 6.2.

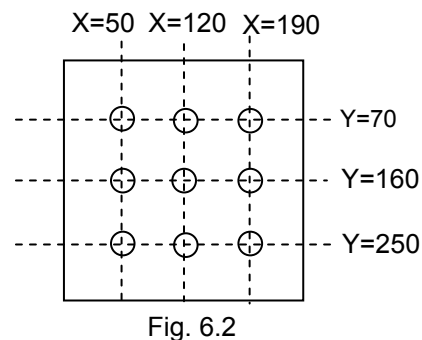
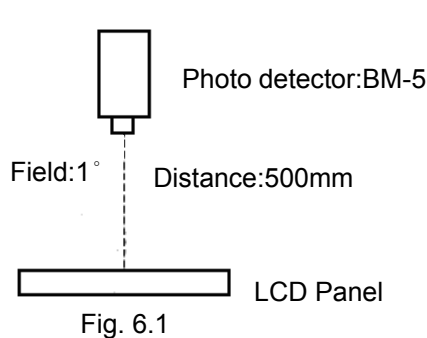

Note 3: The contrast ratio is measured from the center point of the panel, P5, and defined as the following equation:

$$CR = \frac{\text{Brightness of White}}{\text{Brightness of Black}}$$

Note 4: The definition of response time is shown in Fig. 6.3. Rising time is the period from 90% brightness down to 10% brightness when the data is from white turning to black. Oppositely, Falling time is the period from 10% brightness rising to 90% brightness.

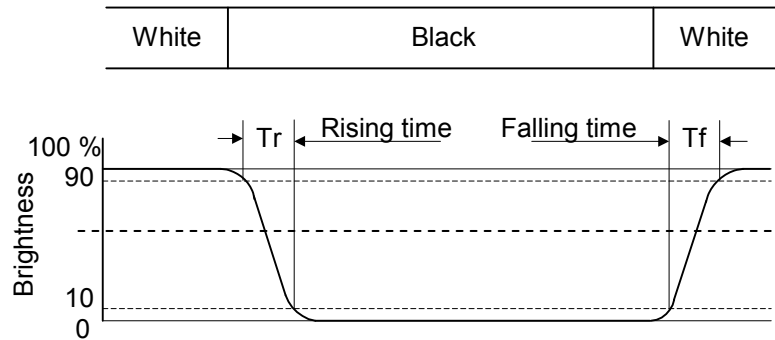

Fig . 6.3

Note 5: The definition of viewing angle is shown in Fig. 6.4. Angle  $\phi$  is used to represent viewing directions, for instance,  $\phi = 270^\circ$  means 6 o'clock, and  $\phi = 0^\circ$  means 3 o'clock. Moreover, angle  $\theta$  is used to represent viewing angles from axis Z toward plane XY.

The viewing direction of this display is 6 o'clock, which means that a photograph with gray scale would not be reversed in color and the brightness change would be less from this direction. However, the contrast peak would be located at 12 o'clock.

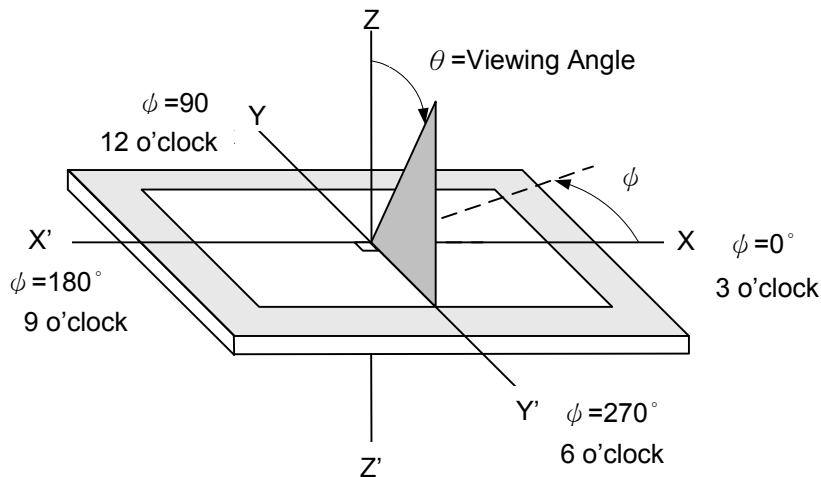
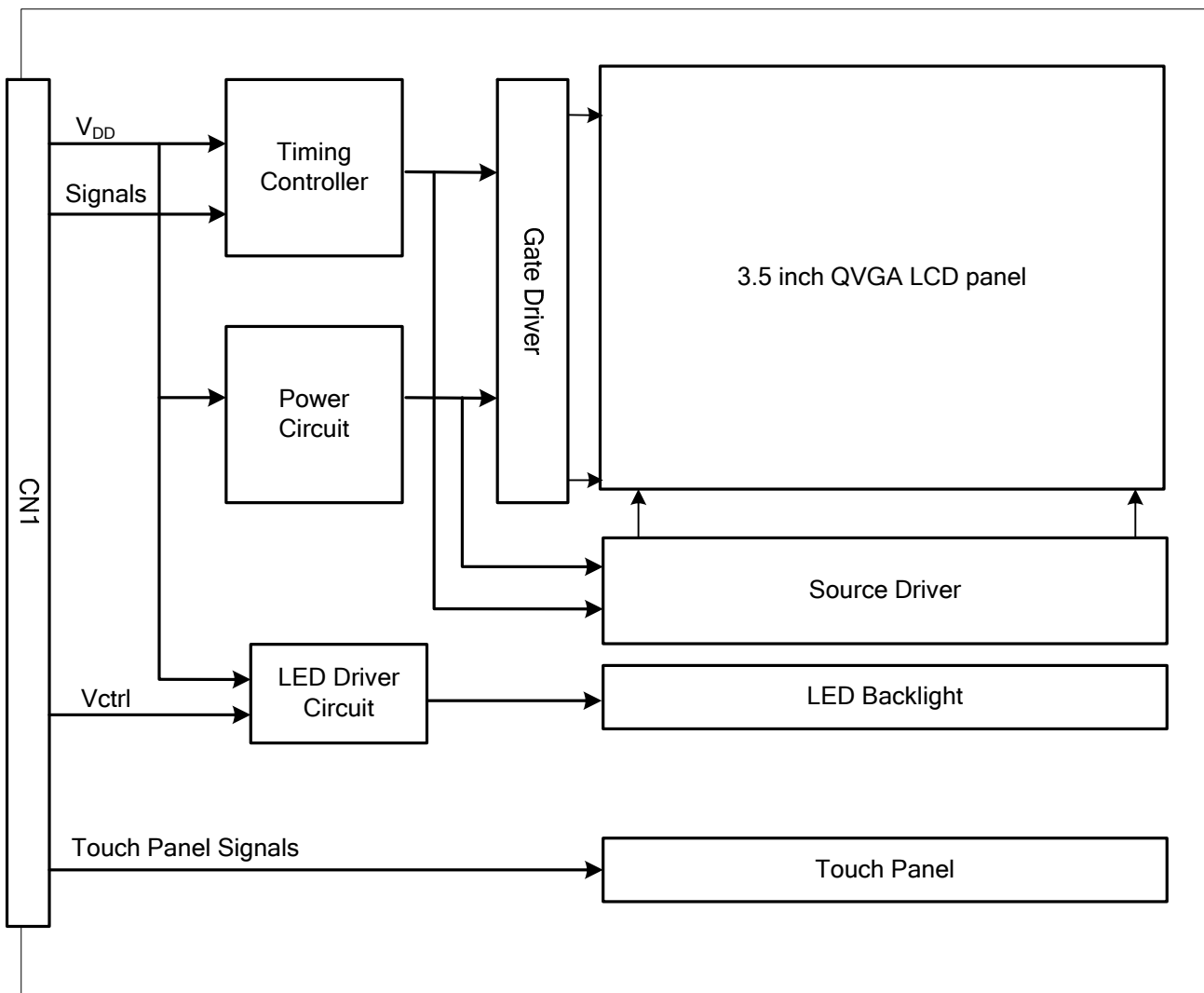

Fig. 6.4

Note 6: The color chromaticity is measured from the center point of the panel, P5, as shown in Fig. 6.2.

## 7. BLOCK DIAGRAM



Note 1: Signals are DTMG, DCLK and RGB data bus.

## 8. RELIABILITY TESTS

Test Item	Condition	
High Temperature	1) Operating 2) 70 °C	240 hrs
Low Temperature	1) Operating 2) -20 °C	240 hrs
High Temperature	1) Storage 2) 80 °C	240 hrs
Low Temperature	1) Storage 2) -30 °C	240 hrs
Heat Cycle	1) Operating 2) -20 °C ~70 °C 3) 3hrs~1hr~3hrs	240 hrs
Thermal Shock	1) Non-Operating 2) -35 °C ↔ 85 °C 3) 0.5 hr ↔ 0.5 hr	240 hrs
High Temperature & Humidity	1) Operating 2) 40 °C & 85%RH 3) Without condensation	240 hrs (Note 3)
Vibration	1) Non-Operating 2) 20~200 Hz 3) 2G 4) X, Y, and Z directions	1 hr for each direction
Mechanical Shock	1) Non-Operating 2) 10 ms 3) 50G 4) ±X, ± Y and ±Z directions	Once for each direction
ESD	1) Operating 2) Tip: 150 pF, 330 Ω 3) Air discharge for glass: ±8KV 4) Contact discharge for metal frame: ±8KV	1) Glass: 9 points 2) Metal frame: 8 points (Note4)

Note 1: Display functionalities are inspected under the conditions defined in the specification after the reliability tests.

Note 2: The display is not guaranteed for use in corrosive gas environments.

Note 3: Under the condition of high temperature & humidity, if the temperature is higher than 40°C, the humidity needs to be reduced as Fig. 8.1 shown.

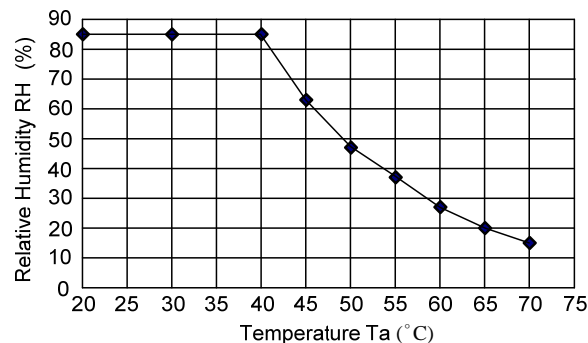

Fig. 8.1

Note 4: All pins of LCD interface(CN1) have been tested by ± 100V contact discharge of ESD under non-operating condition.

## 9. LCD INTERFACE

### 9.1 INTERFACE PIN CONNECTIONS

The connector of display interface is FA5S040HP1R3000 made by JAE (Thickness:  $0.3 \pm 0.05\text{mm}$ ; Pitch:  $0.5 \pm 0.05\text{mm}$ ) and more details of the connector are shown in the section of outline dimension.

Pin assignment of LCD interface is as below:

Pin No.	Signal	Function	Pin No.	Signal	Function
1	V <sub>DD</sub>	Power Supply for Logic	21	G4	Green Data
2	V <sub>DD</sub>		22	G3	
3	V <sub>DD</sub>		23	V <sub>SS</sub>	GND
4	DCLK	Dot Clock	24	G2	Green Data
5	V <sub>SS</sub>	GND	25	G1	
6	HSYNC	Horizontal Sync Pulse	26	G0	
7	V <sub>SS</sub>	GND	27	V <sub>SS</sub>	GND
8	DTMG	Timing Signal for Data	28	B5	Blue Data
9	V <sub>SS</sub>	GND	29	B4	
10	NC	No Connection	30	B3	
11	V <sub>SS</sub>	GND	31	V <sub>SS</sub>	GND
12	R5	Red Data	32	B2	Blue Data
13	R4		33	B1	
14	R3		34	B0	
15	V <sub>SS</sub>	GND	35	PCI	Power Control In (Note 1)
16	R2	Red Data	36	Vctrl	LED Current Control
17	R1		37	xR	Touch Panel Right Side
18	R0		38	yL	Touch Panel Lower Side
19	V <sub>SS</sub>	GND	39	xL	Touch Panel Left Side
20	G5	Green Data	40	yU	Touch Panel Upper Side

Note 1: Please follow the page 9-4/6 to set the PCI.

## 9.2 TIMING CHART

(Data is latched negative edge trigger of DCLK)

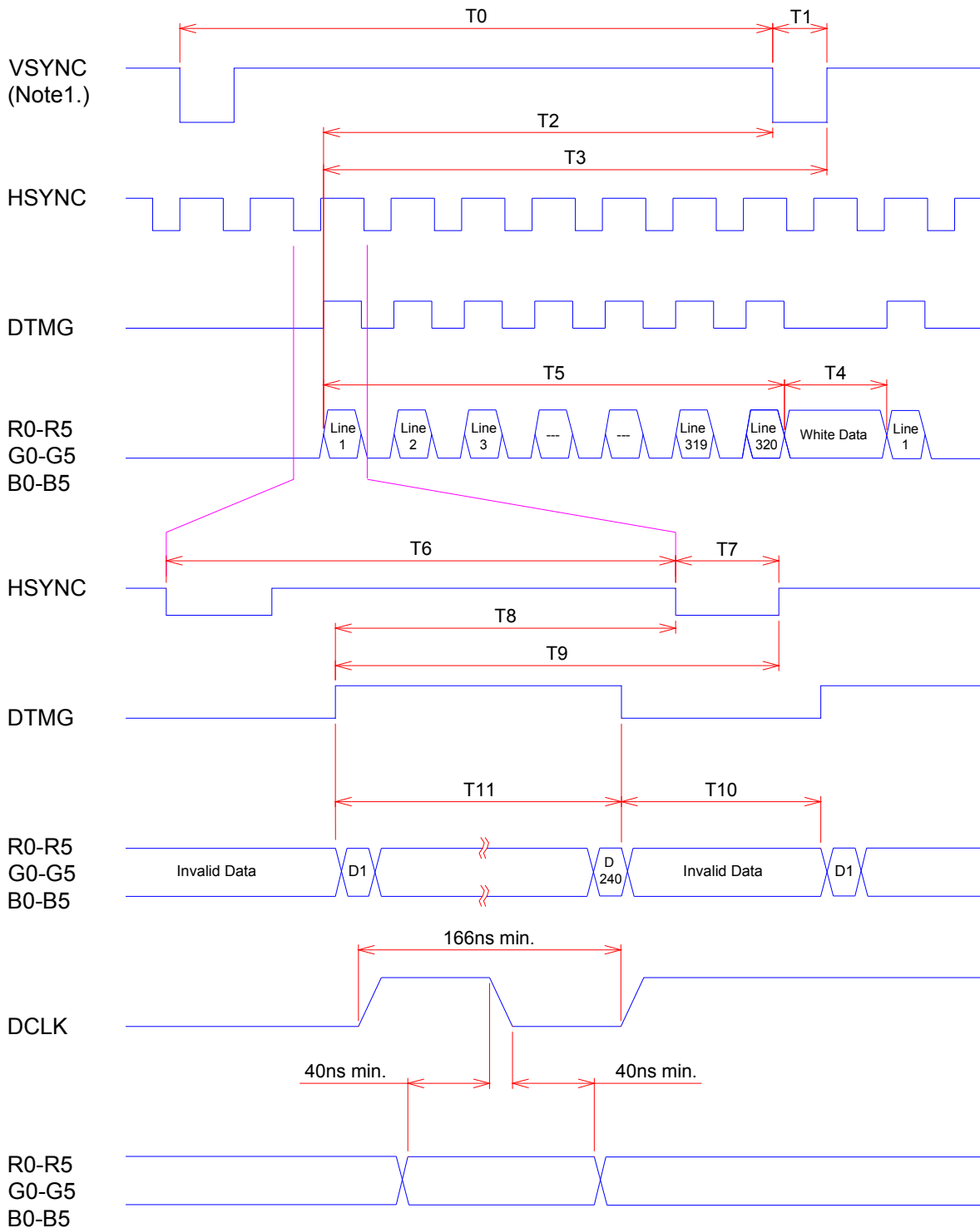

Fig.9.1 Timing sequence for Graphic controller

Note 1: VSYNC is generated by Tcon IC.

### 9.3 INTERFACE TIMING SPECIFICATIONS

ITEM	MIN.	TYP.	MAX.	UNIT	SYMBOL
Vertical Total	-	327	-	Line	T0
Vertical Sync Width	1	1	-	Line	T1
Vertical Sync Start	-	322	-	Line	T2
Vertical Sync End	-	323	-	Line	T3
Vertical Blank Time	5	7	-	Line	T4
Vertical Display End	-	320	-	Line	T5
Horizontal Total	265	273	509	Pixel Clock	T6
Horizontal Sync Width	4	5	10	Pixel Clock	T7
Horizontal Sync Start	244	251	307	Pixel Clock	T8
Horizontal Sync End	248	256	317	Pixel Clock	T9
Horizontal Blank Time	25	33	269	Pixel Clock	T10
Horizontal Display End	-	240	-	Pixel Clock	T11

Note: Vertical total should be set to odd.

# 9.4 POWER SEQUENCE

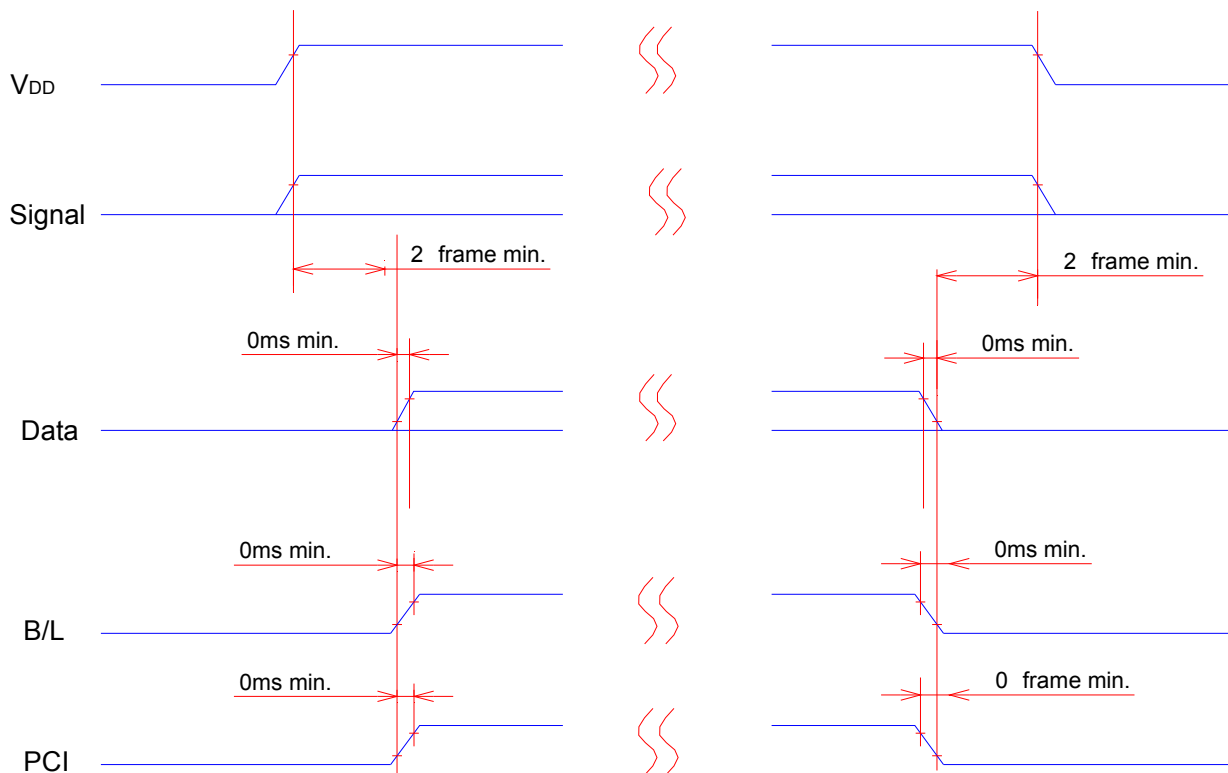

NOTE :

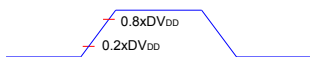



### 9.5 DATA INPUT for DISPLAY COLOR

Input color		Red Data						Green Data						Blue Data					
		R5	R4	R3	R2	R1	R0	G5	G4	G3	G2	G1	G0	B5	B4	B3	B2	B1	B0
		MSB			LSB			MSB			LSB			MSB			LSB		
Basic color	Black	0	0	0	0	0	0	0	0	0	0	0	0	0	0	0	0	0	0
	Red(63)	1	1	1	1	1	1	0	0	0	0	0	0	0	0	0	0	0	0
	Green(63)	0	0	0	0	0	0	1	1	1	1	1	1	0	0	0	0	0	0
	Blue(63)	0	0	0	0	0	0	0	0	0	0	0	0	1	1	1	1	1	1
	Cyan	0	0	0	0	0	0	1	1	1	1	1	1	1	1	1	1	1	1
	Magenta	1	1	1	1	1	1	0	0	0	0	0	0	1	1	1	1	1	1
	Yellow	1	1	1	1	1	1	1	1	1	1	1	1	0	0	0	0	0	0
	White	1	1	1	1	1	1	1	1	1	1	1	1	1	1	1	1	1	1
Red	Black	0	0	0	0	0	0	0	0	0	0	0	0	0	0	0	0	0	0
	Red (1)	0	0	0	0	0	1	0	0	0	0	0	0	0	0	0	0	0	0
	Red (2)	0	0	0	0	1	0	0	0	0	0	0	0	0	0	0	0	0	0
	:	:	:	:	:	:	:	:	:	:	:	:	:	:	:	:	:	:	:
	:	:	:	:	:	:	:	:	:	:	:	:	:	:	:	:	:	:	:
	Red (62)	1	1	1	1	1	0	0	0	0	0	0	0	0	0	0	0	0	0
	Red (63)	1	1	1	1	1	1	0	0	0	0	0	0	0	0	0	0	0	0
Green	Black	0	0	0	0	0	0	0	0	0	0	0	0	0	0	0	0	0	0
	Green (1)	0	0	0	0	0	0	0	0	0	0	0	1	0	0	0	0	0	0
	Green (2)	0	0	0	0	0	0	0	0	0	0	1	0	0	0	0	0	0	0
	:	:	:	:	:	:	:	:	:	:	:	:	:	:	:	:	:	:	:
	:	:	:	:	:	:	:	:	:	:	:	:	:	:	:	:	:	:	:
	Green (62)	0	0	0	0	0	0	1	1	1	1	1	0	0	0	0	0	0	0
	Green (63)	0	0	0	0	0	0	1	1	1	1	1	1	0	0	0	0	0	0
Blue	Black	0	0	0	0	0	0	0	0	0	0	0	0	0	0	0	0	0	0
	Blue (1)	0	0	0	0	0	0	0	0	0	0	0	0	0	0	0	0	0	1
	Blue (2)	0	0	0	0	0	0	0	0	0	0	0	0	0	0	0	0	1	0
	:	:	:	:	:	:	:	:	:	:	:	:	:	:	:	:	:	:	:
	:	:	:	:	:	:	:	:	:	:	:	:	:	:	:	:	:	:	:
	Blue (62)	0	0	0	0	0	0	0	0	0	0	0	0	1	1	1	1	1	0
	Blue (63)	0	0	0	0	0	0	0	0	0	0	0	0	1	1	1	1	1	1





# 11. TOUCH PANEL

The type of touch panel used on this display is resistive, analog, 4-wire and film on glass, and more characteristics are shown as below:

## 11.1 OPERATING CONDITIONS

Item	Specification	Remarks
Operating Voltage	5VDC	7V MAX

## 11.2 ELECTRICAL CHARACTERISTICS

Item	Specification	Remarks
Resistance Between Terminal	XR-XL	100~750Ω
	YU-YL	310~950Ω
Insulation Resistance	X-Y	20MΩ min. At 25V DC
Linearity	X	±1.5% max.
	Y	±1.5% max.
Chattering	10ms max.	-

Note 1: The test conditions and equipments of linearity are as below:

- Material of pen: poly-acetal resin
- End shape: R 0.8 mm
- Test force: 80 g
- Pitch: 10 mm
- Test area is shown in Fig. 11.1

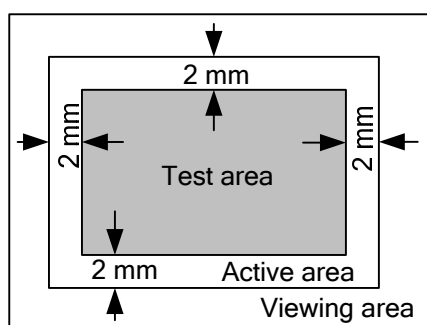

Fig. 11.1

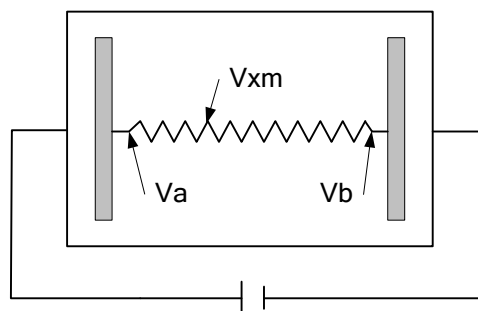

Fig. 11.2

As shown in Fig. 11.2, applying voltage meter to measure Va, Vb and Vxm, where Va is the maximum voltage in the active area; Vb is the minimum voltage in the active area; Vxm is the measured voltage of point x selected by random. Afterwards, the linearity can be calculated by following equation:

$$\text{Linearity} = \frac{|V_{xi} - V_{xm}|}{V_a - V_b} \times 100\%$$

where Vxi is the idea voltage of point x.

The method to measure the linearity of Y-axis is the same as above.

### 11.3 MECHANICAL CHARACTERISTICS

Item	Specification	Remarks
Pen Input Pressure	20~80g	R0.8, Polyacetal Pen
Surface Hardness	3H min.	JIS K-5600-5-4

### 11.4 OPTICAL CHARACTERISTICS

Item	Specification	Remarks
Transmittance	80% min.	-

### 11.5 SAFETY AND ATTENTIONS

- 1) Do not put heavy shock or stress on the touch panel.
- 2) Please use soft cloth or absorbent cotton with ethanol to clean the touch panel by gently wiping. Moreover, please wipe it by horizontal or vertical direction instead of circling to prevent leaving scars on the touch panel's surface.
- 3) Do not use any harmful chemicals such as acetone, toluene, and isopropyl alcohol to clean the display's surface.
- 4) UV protection is recommended to avoid the possibility of performance degrading when touch panel is likely applied under UV environment for a long period of time.

## 12. APPEARANCE STANDARD

The appearance inspection is performed in a room around 500~1000 lx based on the conditions as below:

- The distance between inspector's eyes and display is 30 cm.
- The viewing zone is defined with angle  $\theta$  shown in Fig. 12.1 The inspection should be performed within  $45^\circ$  when display is shut down. The inspection should be performed within  $5^\circ$  when display is power on.

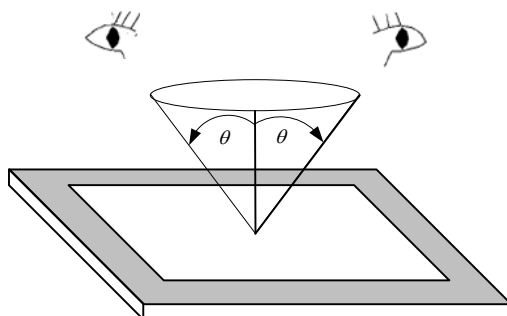

Fig. 12.1

### 12.1 THE DEFINITION OF LCD ZONE

LCD panel is divided into 2 areas as shown in Fig.12.2 for appearance specification in next section. A zone is the LCD active area (dot area); B zone is the area between A zone and metal frame.

In terms of housing design, B zone is the recommended window area customers' housing should be located in.

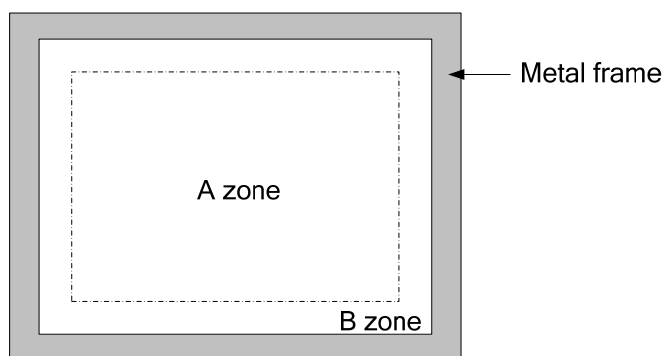

Fig. 12.2

## 12.2 LCD APPEARANCE SPECIFICATION

The specification as below is defined as the amount of unexpected phenomenon or material in different zones of LCD panel. The definitions of length, width and average diameter using in the table are shown in Fig. 12.3 and Fig. 12.4.

Item	Criteria			Applied zone
Scratches	Length / L(mm)	Width / W(mm)	Maximum number Acceptable	A,B
	$L \leq 2.0$	$W \leq 0.03$	Ignored	
	$L \leq 2.0$	$0.03 < W \leq 0.05$	4	
	$2.0 < L$	$0.05 < W$	None	
Dent	Serious one is not allowed.			A
Wrinkles in Polarizer	Serious one is not allowed.			A
Bubbles on Polarizer	Average diameter / D(mm)		Maximum number Acceptable	A
	$D \leq 0.3$		2	
	$0.3 < D$		None	
1) Stains 2) Foreign Materials 3) Dark Spot	Filamentous (Line shape)			A,B
	Length / L(mm)	Width / W(mm)	Maximum number Acceptable	
	$L < 2.0$	$W \leq 0.05$	4	
	$L \leq 1.0$	$0.05 < W \leq 0.1$	2	
	Round (Dot shape)			A,B
	Average diameter / D(mm)		Maximum number acceptable	
	$D \leq 0.15$		6	
	$0.15 < D \leq 0.2$		4	
	$0.2 < D$		None	
	In total		Filamentous + Round=9	
Those wiped out easily are acceptable.				
Dot-Defect (Note 1)	Type		Maximum number acceptable	A,B
	Sparkle mode	1 dot	4	
		2 dots	2(sets)	
		In total	4	
	Black mode	1 dot	4	
		2 dots	2(sets)	
		In total	4	
	Sparkle mode & Black mode	2 dots	2(sets)	
In total		6		

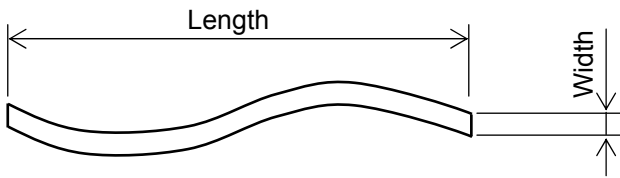

Fig 12.3

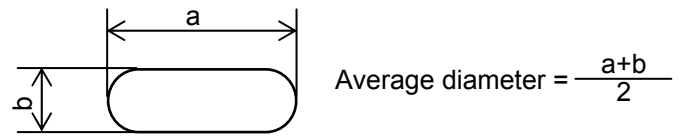
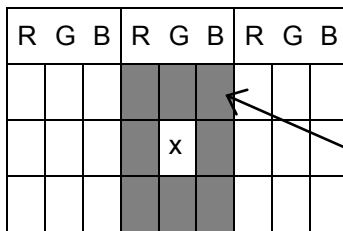

Fig 12.4

Note 1: The definitions of dot defect are as below:

- The defect area of the dot must be bigger than half of a dot.
- For bright dot-defect, showing black pattern, the dot's brightness must be over 30% brighter than others.
- For dark dot-defect, showing white pattern, the dot's brightness must be under 70% darker than others.
- The definition of 1-dot-defect is the defect-dot, which is isolated and no adjacent defect-dot.
- The definition of adjacent dot is shown as Fig. 12.5.



The dots colored in gray are adjacent to defect - dot "X".

Fig 12.5



### 12.3 TOUCH PANEL APPEARANCE SPECIFICATION

The specification as below is defined by the amount of unexpected material in different zones of touch panel.

Item	Criteria			Applied zone
Scratches	Length / L(mm)	Width / W(mm)	Maximum number acceptable	A,B
	-	$W < 0.05$	Ignored	
	$10 < L$	$0.05 \leq W < 0.1$	None	
	-	$0.1 \leq W$	None	
Foreign Materials	Filamentous (Line shape)			A,B
	Length / L(mm)	Width / W(mm)	Maximum number acceptable	
	-	$W \leq 0.05$	Ignored	
	$3 < L$	$0.05 < W \leq 0.1$	None	
	-	$0.1 \leq W$	None	
	Round (Dot shape)			A,B
	Average diameter / D(mm)		Maximum number acceptable	
	$D \leq 0.25$		Ignored	
	$0.25 < D \leq 0.35$		6	
	$0.35 < D$		None	

The limitation of glass flaw occurred on touch panel is defined in the table as below.

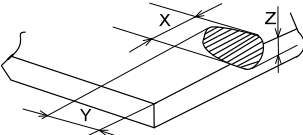
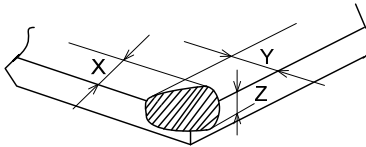
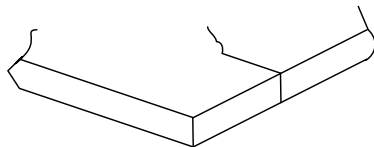
Item	Specifications	
Edge flaw		$X \leq 5.0 \text{ mm}$ $Y \leq 3.0 \text{ mm}$ $Z \leq \text{Thickness}$
Corner flaw		$X \leq 3.0 \text{ mm}$ $Y \leq 3.0 \text{ mm}$ $Z \leq \text{Thickness}$
Progressive flaw		Not allowed

## 13. PRECAUTIONS

### 13.1 PRECAUTIONS of MOUNTING

1) Please refer to Fig. 13.1 for housing the display with touch panel into applications. The Fig. 13.1 shows some points as below:

- The cushion needs to be designed between housing and touch panel in order to avoid unexpected pressure to cause any wrong reactions, and the cushion should be located in the insulated area.
- The housing should not cover the active area of touch panel as the figure shown.

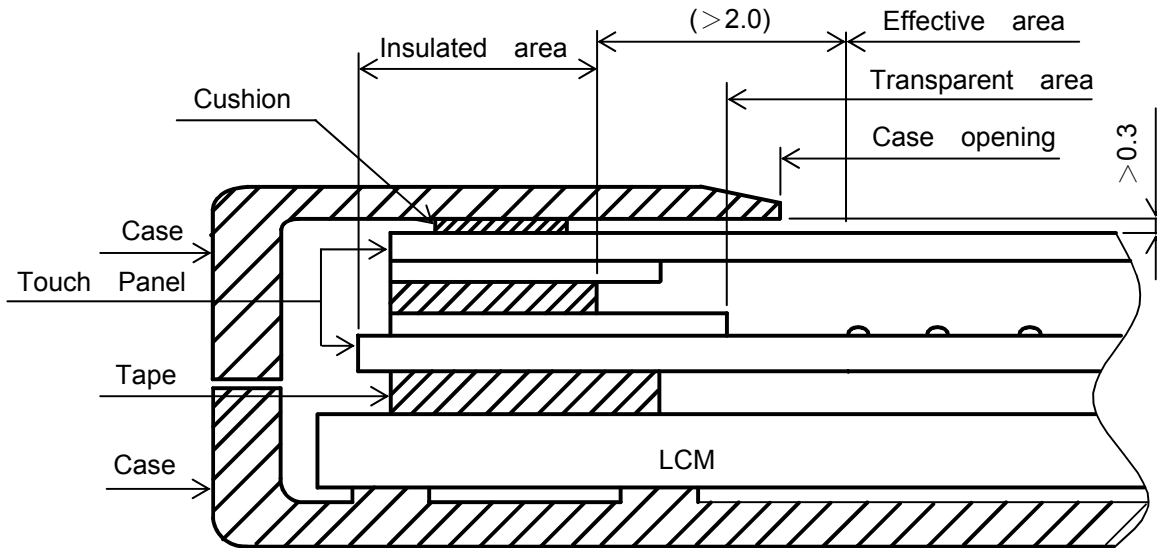

Fig 13.1

### 13.2 PRECAUTIONS of ESD

- 1) Before handling the display, please ensure your body has been connected to ground to avoid any damages by ESD. Also, do not touch display's interface directly when assembling.
- 2) Please remove the protection film very slowly before turning on the display to avoid generating ESD.

### 13.3 PRECAUTIONS of HANDLING

- 1) In order to keep the appearance of display in good condition, please do not rub any surfaces of the displays by sharp tools harder than 3H, especially touch panel, metal frame and polarizer.
- 2) Please do not pile the displays in order to avoid any scars leaving on the display. In order to avoid any injuries, please pay more attention for the edges of glasses and metal frame, and wear finger cots to protect yourself and the display before working on it.
- 3) Touching the display area or the terminal pins with bare hand is prohibited. This is because it will stain the display area and cause poor insulation between terminal pins, and might affect display's electrical characteristics furthermore.
- 4) Do not use any harmful chemicals such as acetone, toluene, and isopropyl alcohol to clean display's surfaces.
- 5) Please use soft cloth or absorbent cotton with ethanol to clean the display by gently wiping. Moreover, when wiping the display, please wipe it by horizontal or vertical direction instead of circling to prevent leaving scars on the display's surface, especially polarizer.

- 6) Please wipe any unknown liquids immediately such as saliva, water or dew on the display to avoid color fading or any permanently damages.
- 7) Maximum pressure to the surface of the display must be less than  $1,96 \times 10^4$  Pa. If the area of adding pressure is less than  $1 \text{ cm}^2$ , the maximum pressure must be less than 1.96N.

### 13.4 PRECAUTIONS OF OPERATING

- 1) Please input signals and voltages to the displays according to the values defined in the section of electrical characteristics to obtain the best performance. Any voltages over than absolute maximum rating will cause permanent damages to this display. Also, any timing of the signals out of this specification would cause unexpected performance.
- 2) When the display is operating at significant low temperature, the response time will be slower than it at  $25 \text{ C}^\circ$ . In high temperature, the color will be slightly dark and blue compared to original pattern. However, these are temperature-related phenomenon of LCD and it will not cause permanent damages to the display when used within the operating temperature.
- 3) The use of screen saver or sleep mode is recommended when static images are likely for long periods of time. This is to avoid the possibility of image sticking.
- 4) Spike noise can cause malfunction of the circuit. The recommended limitation of spike noise is no bigger than  $\pm 100 \text{ mV}$ .

### 13.5 PRECAUTIONS of STORAGE

If the displays are going to be stored for years, please be aware the following notices.

- 1) Please store the displays in a dark room to avoid any damages from sunlight and other sources of UV light.
- 2) The recommended long term storage temperature is between  $10 \text{ C}^\circ \sim 35 \text{ C}^\circ$  and 55%~75% humidity to avoid causing bubbles between polarizer and LCD glasses, and polarizer peeling from LCD glasses.
- 3) It would be better to keep the displays in the container, which is shipped from KOE, and do not unpack it.
- 4) Please do not stick any labels on the display surface for a long time, especially on the polarizer.

## 14. DESIGNATION of LOT MARK

1) The lot mark is showing in Fig.14.1. First 4 digits are used to represent production lot, T represented made in Taiwan, and the last 6 digits are the serial number.

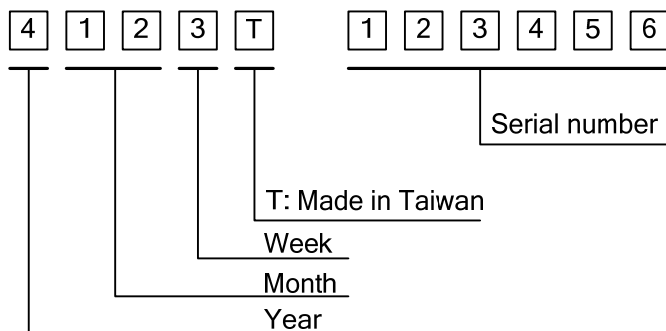

Fig. 14.1

2) The tables as below are showing what the first 4 digits of lot mark are shorted for.

Year	Lot Mark
2014	4
2015	5
2016	6
2017	7
2018	8

Month	Lot Mark	Month	Lot Mark
Jan.	01	Jul.	07
Feb.	02	Aug.	08
Mar.	03	Sep.	09
Apr.	04	Oct.	10
May	05	Nov.	11
Jun.	06	Dec.	12

Week	Lot Mark
1~7 days	1
8~14 days	2
15~21 days	3
22~28 days	4
29~31 days	5

3) Except letters I and O, revision number will be shown on lot mark and following letters A to Z.

REV.No	ITEM	REMARKS
A	-	-
B	1. Changed DC/DC Converter Circuit Design changed 2. Barcode label	PCN0683
C	Connectors Changed	PCN0804
D	Film of TP Changed	PCN0852
E	LCD Production Line Changed	PCN0885

4) The location of the lot mark is on the back of the display shown in Fig. 14.2.



Fig. 14.2